

BLF/BLFR Hydraulic linear single-acting spring-closing actuator

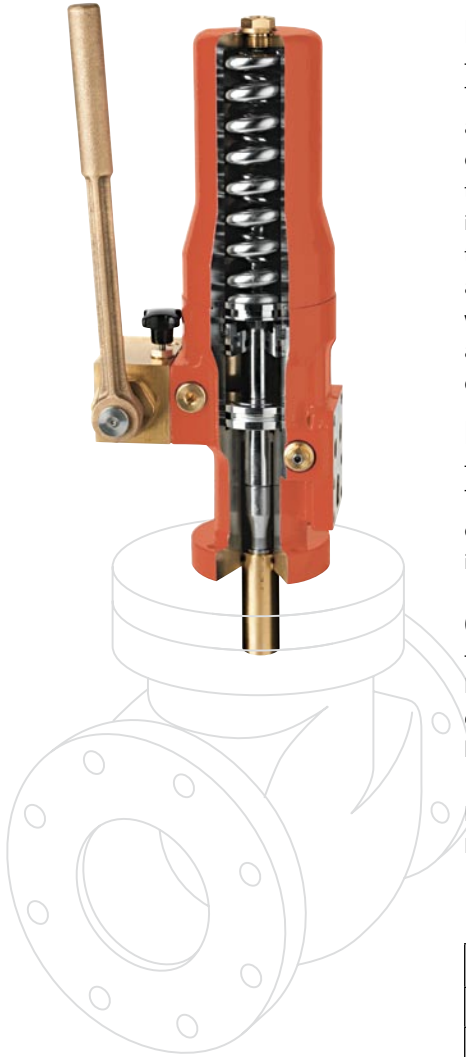

Description:

The BLF/BLFR is designed as hydraulic fail close actuators. When the actuator is operated by hydraulic pressure, the output spindle is lifted (and the valve is thus opened) and the spring package is compressed. When the pressure is released, the spring package will press down the spindle and close the valve. The BLF/BLFR is designed with built-in crossover valve and is equipped with a direct visual position indicator. The BLF/BLFR can be operated in any kind of environment and is

easily adapted to all well-known globe valves, and all models are prepared for direct built-in modular control functions. The BLF/BLFR is also equipped with a unique emergency system; when the hydraulic pressure is not available, the valve can be opened and closed by means of a built-in manual hand pump (Model BLFR). When the pressure is reestablished, the manual hand pump function is automatically disengaged at the first hydraulic opening of the actuator.

Manufacture:

The BLF/BLFR actuators are manufactured in accordance with the guidelines for quality system stated in the American standard ANSI/ASQC Z-1.15. After

assembly, each actuator is flushed to NAS 1638/10 standard and plugged. Flushing to NAS 1648/7 standard can be performed on request.

Classification:

Meets the requirements from the major classification and approval authorities like:

Det Norske Veritas
 Lloyd's Register of Shipping

American Bureau of Shipping
 Rina
 Russian Register of Shipping
 Bureau of Veritas
 Germanischer Lloyd
 U.S. Coast Guard

Main data:

Temperature range:	-20° C to +80° C (-5° F to +180° F)
Housing:	GGG40 (Ductile Iron)
Piston:	GGG40 (Ductile Iron)
Output spindle:	Brass, other material on request
Indicator housing:	Brass MS 58
Intermediate flange:	St 52-3, (Carbon Steel)
Coating:	Primer: Min 40 micron, type Hempel EE 13140 Top coat: Min 25 micron alkyd, orange RAL 2002

BLF/BLFR

Main dimensions:

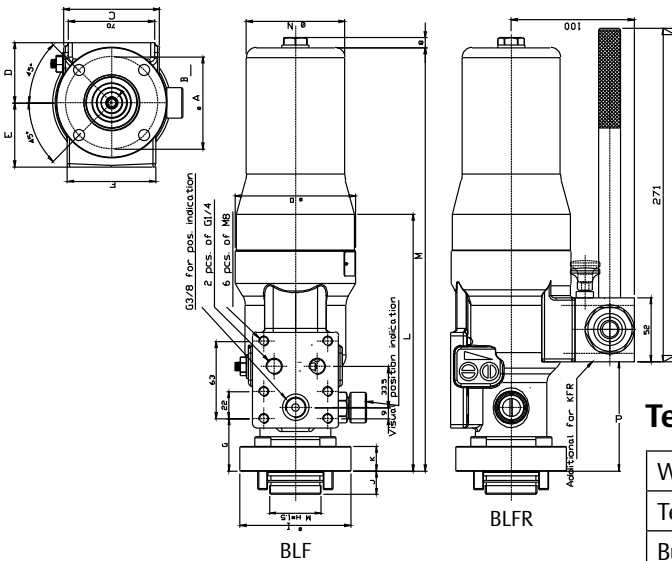

Technical data:

Working pressure:	135 bar (2000 psi)
Test pressure:	1.5 x working pressure
Burst test:	min. 675 bar
End closing thrust (spring):	1500-16500 N (1100 lbf - 12,000 lbf)
Viscosity of hydraulic oil:	15 to 200 cSt

Dimensions:

Thrust Weight	lbf	N
	lb	Kg
Displacement	cu.in.	litres
Dimensions	inches	mm

Model	End Closing Thrust	Stroke	Weight	Displacement	Dimensions Bottom View						Dimensions Front View														
					A	B	C	D	E	F	G	H	I	J	K	L	M	N	O	P	Q	R	S	T	U
BLF 65	337	1	13	1.28	2	0	3.15	1.87	-	-	1.36	1.42	2.99	0.67	0.59	6.30	8.86	2.52	3.15	0.79	-	0.36	1.32	0.87	2.48
	1500	16.25	6	0.021	62	9	80	47.5	-	-	34.5	36	76	17	15	160	225	64	80	20	-	9	33.5	22	63
BLF 125	1079	1	24	5.00	3	0	3.07	1.97	2.05	2.83	1.67	1.65	3.54	0.75	0.79	8.23	13.58	3.15	3.84	0.98	3.50	0.36	1.32	0.87	2.48
	4800	31.25	11	0.082	75	9	78	50	52	72	42.5	42	90	19	20	209	345	80	97.5	25	89	9	33.5	22	63
BLF 250	3709	2	112	26.12	5	1	2.76	3.31	3.07	2.83	2.91	2.83	5.51	0.91	1.38	12.95	23.70	5.91	6.10	1.97	6.10	0.36	1.32	0.87	2.48
	16500	62.5	51	0.428	118	14	70	84	78	72	74	72	140	23	35	329	602	150	155	50	155	9	33.5	22	63

*Higher torques on request - For lower pressure supply consult factory.

Standard features:

The BLF/BLFR actuator for fail safe close operation of globe valves:

- Unique and simple design with built-in crossover valve
- Easy installation on intermediate flange at globe valve
- Same unit for several valve sizes
- Will operate in sea air as well as sea water
- No external moving parts during operation
- Prepared for direct built-on modular control functions or LPU
- Built-in hydraulic emergency operation for BLFR
- Direct visual position indication
- Electrical on/off or continuous position indication IP 68
- Connection block with filter
- Throttle valve
- Quick connection for emergency operation
- with portable hand pump (BLFR)
- LPU mounting
- Epoxy coating
- On request special features as:
 - o Flushing valve built into the connection block making it possible to flush the system without disconnection of pipes
 - o Fail open actuator (BLF only)

Note: Not Certified dimensional drawings. Such drawings are available on request. Contact factory with correct model designation and serial number. Important: Due to Emerson's continuing commitment to engineered product advancement, data presented herein is subject to change.

The contents of the publication are presented for information purposes only, and while effort has been made to ensure their accuracy, they are not to be construed as warranties or guarantees, express or implied, regarding the products or services described herein or their use or applicability. All sales are governed by our terms and conditions, which are available on request. We reserve the right to modify or improve the designs or specifications of our products at any time without notice.