

## Data sheet

Sheet No.: BL1.01 RevA

Date: October 2010

BL

# BL Hydraulic linear single-acting actuator

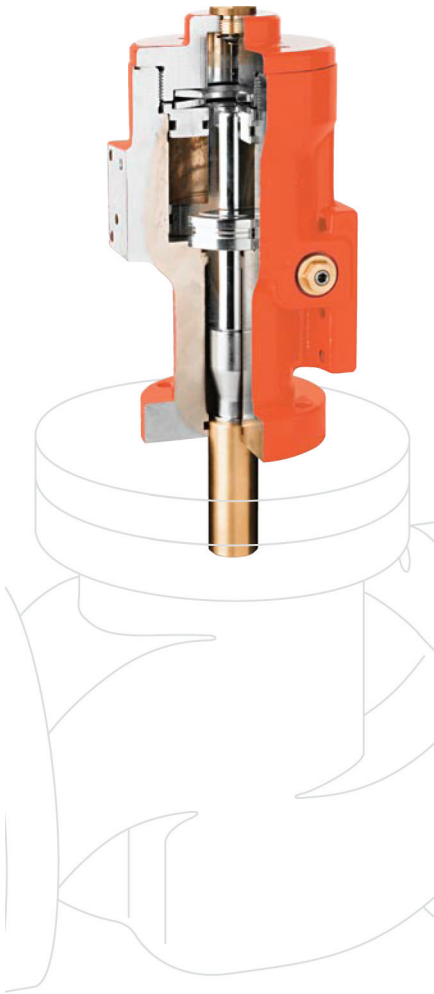

## Description:

The BL actuator converts hydraulic energy into linear motion with thrust proportional to the applied pressure. The BL has no external moving parts during operation and has a built-in device for maintaining pressure at temperature variations. The BL is designed with built-in crossover valve and is equipped with a direct visual position indicator. The BL actuator can be operated in any kind of environment and can easily be adapted to all well-known globe valves, and all models are prepared for direct built-on modular control functions.

## Manufacture:

The BL actuators are manufactured in accordance with the guidelines for quality system stated in the American standard ANSI/ASQC Z-1.15.

After assembly, each actuator is flushed to NAS 1638/10 standard and plugged. Flushing to NAS 1648/7 standard can be performed on request.

## Classification:

Meets the requirements from the major classification and approval authorities like:

Det Norske Veritas  
Lloyd's Register of Shipping

American Bureau of Shipping  
Rina  
Russian Register of Shipping  
Bureau of Veritas  
Germanischer Lloyd  
U.S. Coast Guard

## Main data:

Temperature range:	-20°C to +80°C (-5°F to +180°F)
Housing:	GGG40 (Ductile Iron)
Piston:	GGG40 (Ductile Iron)
Output spindle:	Brass, other material on request
Indicator housing:	Brass MS 58
Intermediate flange:	St 52-3, (Carbon Steel)
Coating:	Primer: Min 40 micron, type Hempel EE 13140 Top coat: Min 25 micron alkyd, orange RAL 2002

**BETTIS™**

www.Bettis.com

Copyright © Emerson Process Management. The information in this document is subject to change without notice.

Updated data sheets can be obtained from our website [www.bettis.com](http://www.bettis.com) or from your nearest Valve Automation Center.

USA: +1 281 727 5300 Europe: +31 74 256 1010 Asia-Pacific: +65 6501 4600

  
**EMERSON™**  
Process Management

# Data sheet

Sheet No.: BL1.02 RevA  
Date: October 2010

BL

## Main dimensions: (Inches in parenthesis)

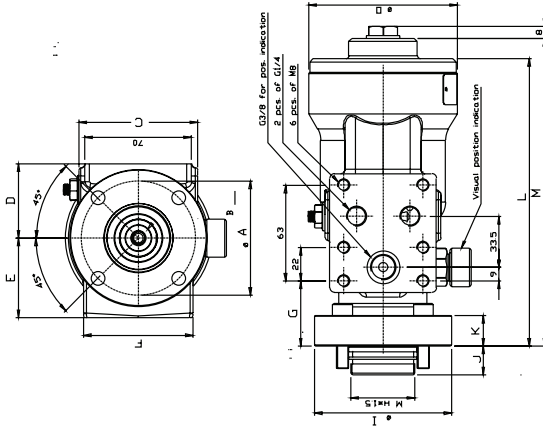

## Technical data:

Working pressure:	135 bar (2000 psi)
Test pressure:	1.5 x working pressure
Burst test:	min. 675 bar
End closing thrust (spring):	17000-92500 N
Viscosity of hydraulic oil:	15 to 200 cSt

## Dimensions:

Thrust	lbf	N
Weight	lb	Kg
Displacement	cu.in.	litres
Dimensions	inches	mm

Model	Thrust at 1550 psi (108 bar)	Thrust at 1950 psi (135 bar)	Stroke	Weight	Displacement	Dimensions Bottom View						Dimensions Front View													
						A	B	C	D	E	F	G	H	I	J	K	L	M	N	O	P	R	S	T	U
BL 65	3057	3822	0.64	10	1	2.44	0.35	3.15	1.87	-	-	1.36	1.42	2.99	0.67	0.59	6.02	6.22	-	3.15	0.79	0.36	1.32	0.87	2.48
	13600	17000	16.25	4.5	0.021	62	9	80	47.5	-	-	34.5	36	76	17	15	153	158	-	80	20	9	33.5	22	63
BL 125	6295	7868	1.23	15	5	2.95	0.35	3.07	1.97	2.05	2.83	1.67	1.65	3.54	0.75	0.79	7.44	7.95	1.77	3.84	0.98	0.36	1.32	0.87	2.48
	28000	35000	31.25	7	0.082	75	9	78	50	52	72	42.5	42	90	19	20	189	202	45	97.5	25	9	33.5	22	63
BL 250	16636	20795	2.46	53	26	4.65	0.55	2.76	3.31	3.07	2.83	2.91	2.83	5.51	0.91	1.38	11.77	12.64	3.15	6.10	1.97	0.36	1.32	0.87	2.48
	74000	92500	62.5	24	0.428	118	14	70	84	78	72	74	72	140	23	35	299	321	80	155	50	9	33.5	22	63

\*Higher torques on request - For lower pressure supply consult factory.

## Standard features:

The BL actuator for intermediate positions and fail set operation of globe valves:

- Unique and simple design with built-in crossover valve
- Easy installation on intermediate flange at globe valve
- Same unit for several valve sizes
- Will operate in sea air as well as sea water
- No external moving parts during operation
- Prepared for direct built-on modular control functions or LPU
- Direct visual position indication
- Built-in device for maintaining pressure at temperature variations
- Hydraulic on/off position indication
- Electrical on/off or continuous position indication IP 68
- Connection block with filter
- Pilot operated non-return valve
- Release valve
- Throttle valve
- Quick connection for emergency operation with portable hand pump
- LPU mounting
- Epoxy coating
- On request special features as:
  - o Flushing valve built into the connection block making it possible to flush the system without disconnection of pipes

Note: Not Certified dimensional drawings. Such drawings are available on request. Contact factory with correct model designation and serial number.  
Important: Due to Emerson's continuing commitment to engineered product advancement, data presented herein is subject to change.

The contents of the publication are presented for information purposes only, and while effort has been made to ensure their accuracy, they are not to be construed as warranties or guarantees, express or implied, regarding the products or services described herein or their use or applicability. All sales are governed by our terms and conditions, which are available on request. We reserve the right to modify or improve the designs or specifications of our products at any time without notice.

**BETTIS™**

www.Bettis.com

Copyright © Emerson Process Management. The information in this document is subject to change without notice. Updated data sheets can be obtained from our website [www.bettis.com](http://www.bettis.com) or from your nearest Valve Automation Center.  
USA: +1 281 727 5300 Europe: +31 74 256 1010 Asia-Pacific: +65 6501 4600

**EMERSON™**  
Process Management