

Hydraulic double-acting balanced rotary actuator 90° quarter-turn



Manufacture:

The BHH actuators are manufactured in accordance with the guidelines for quality system stated in the ISO standard. After assembly each actuator is flushed according to ISO 4406 19/16 standard and plugged. Flushing according to ISO 4406 16/13 standard can be performed on request.

Classification:

Meets the requirements from the major classification and approval authorities like:

ATEX	Russian Register of Shipping
Lloyd's Register of Shipping	Bureau Veritas
American Bureau of Shipping	Germanischer Lloyd
RINA	U.S. Coast Guard
	IP68 Water Ingress Protection

Main data:

Temperature range:	-20°C to +80°C, (-5°F to +180°F) -40°C to +80°C, (-40°F to +180°F) Optional
Housing:	GGG 40 (Ductile Iron)
Piston:	GGG 40 (Ductile Iron)
Output shaft:	SS 2142 (Alloy Steel)
Indicator shaft:	AISI 316 (Stainless Steel)
Intermediate flange:	St 52-3 (Carbon Steel)
Adapter:	SS 2142 (Alloy Steel)
Coating:	Primer: Min. 40 micron, type Hempel EE 13140 Top coat: min. 25 micron alkyd, orange RAL2002

Operating restrictions:

Please observe specific rules and demands from the classification societies and authorities concerning operating pressure and temperature range. (Example - ABS: Max. operating pressure = 20% of burst pressure). For extreme cycle speeds, loads and lifetime expectations please consult manufacturer.

Turning direction in relation to "A" and "B":

Pressure on "A" -
Indicator slot is moving
clockwise -
Valve closed and
indicator slot is parallel
to mounting area.

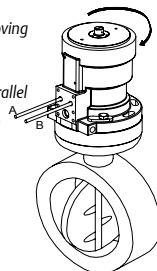

Pressure on "B" -
Indicator slot is moving
counter clockwise -
Valve open and indicator slot
is perpendicular
to the mounting area.

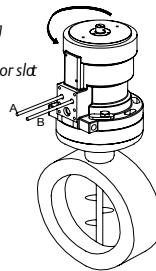

Data sheet

Sheet No.: BHH.02 RevA

Date: October 2010

BHH

The BHH actuator for operation of quarter-turn valves:

- Unique and simple design with builtin crossover valve.
- Compactness and high-torque output.
- Reliable and rugged, with more than 30 years service records on basic design.
- Balanced rotary principle eliminates side forces and/or bending of valve spindle.
- Able to function in salt laden environment, as well as partially submerged service.
- Easy adaption to all well-known quarter-turn valves.
- Unlimited mounting positions with built-in adjustments for end stops of rotary movement.
- Prepared for direct built-on modular control functions.

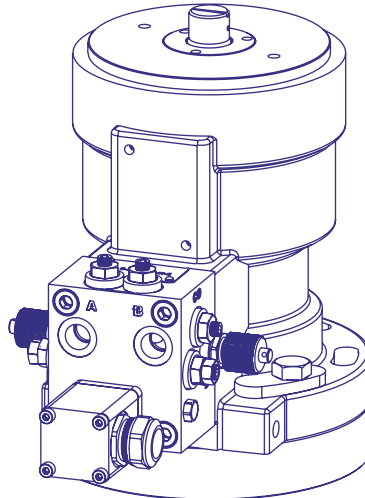
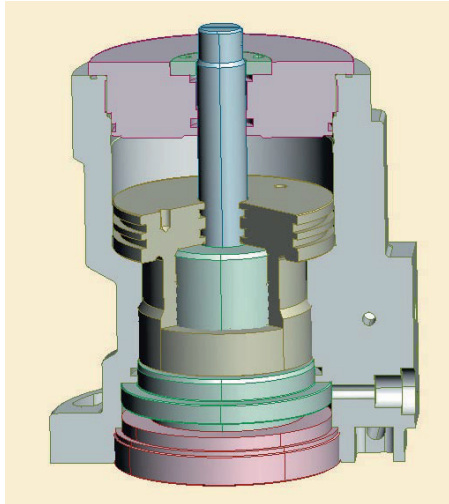

Actuator mounted with control block and EI indicator

Standard options:

- Hydraulic on/off indication (bypass).
- EI on/off or continuous indication IP 68.
- Connection block with e.g. filter.
- Double pilot operated non-return valve.
- Double release valve.
- Double throttle valve.
- Quick connection for emergency operation with portable hand pump.
- Built-on emergency operation hand pump.
- Submersion cover.
- Epoxy coating.

On request, special features available, such as:

- Flushing valve built into the connection block making it possible to flush the system without disconnection of pipes.
- Safety equipment such as mechanical locking device of actuator in closed position.

Actuator mounted control equipment:

See separate data sheet for the whole range of control blocks and other actuator mounted control components. (Interface for Cetop 3 valves).

Note: Not Certified dimensional drawings. Such drawings are available on request. Contact factory with correct model designation and serial number.
Important: Due to Emerson's continuing commitment to engineered product advancement, data presented herein is subject to change.

The contents of the publication are presented for information purposes only, and while effort has been made to ensure their accuracy, they are not to be construed as warranties or guarantees, express or implied, regarding the products or services described herein or their use or applicability. All sales are governed by our terms and conditions, which are available on request.

We reserve the right to modify or improve the designs or specifications of our products at any time without notice.

BETTIS[™]

www.Bettis.com

Copyright © Emerson Process Management. The information in this document is subject to change without notice.

Updated data sheets can be obtained from our website www.bettis.com or from your nearest Valve Automation Center.

USA: +1 281 727 5300 Europe: +31 74 256 1010 Asia-Pacific: +65 6501 4600

EMERSON[™]
Process Management