



Failure Modes, Effects and Diagnostic Analysis

Project:

3051S SIS Pressure Transmitter,
with Safety Feature Board, Software Revision 3.0

Customer:

Rosemount Inc.
Chanhassen, MN
USA

Contract No.: Ros 02/11-07 R2

Report No.: Ros 02/11-07 R001

Version V2, Revision R4, August 27, 2007

William M. Goble – John C. Grebe

Management summary

This report summarizes the results of the Failure Modes, Effects, and Diagnostic Analysis (FMEDA) of the 3051S SIS Pressure Transmitter with Safety Feature Board and Software Revision 3.0. A Failure Modes, Effects, and Diagnostic Analysis is one of the steps to be taken to achieve functional safety certification per IEC 61508 of a device. From the FMEDA, failure rates and Safe Failure Fraction are determined. The FMEDA that is described in this report concerns only the hardware of the 3051S SIS Pressure Transmitter, electronic and mechanical. For full functional safety certification purposes all requirements of IEC 61508 must be considered.

The 3051S SIS Pressure Transmitter is a two-wire, 4 – 20 mA smart device. It contains self-diagnostics and is programmed to send it's output to a specified failure state, either high or low upon internal detection of a failure. For safety instrumented systems usage it is assumed that the 4 – 20 mA output is used as the primary safety variable. All other possible output variants are not covered by this report. The different devices can be equipped with or without display.

Table 1 gives an overview of the different versions that belong to the considered 3051S SIS Pressure Transmitter with Safety Feature Board and Software Revision 3.0.

Table 1: Version overview

3051S_T In-Line	3051 S In-Line Pressure Transmitter
3051S_C Coplanar	3051S Coplanar Pressure Transmitter

The 3051S SIS Pressure Transmitter is classified as a Type B¹ device according to IEC61508, having a hardware fault tolerance of 0. The analysis shows that the device has a Safe Failure Fraction between 90 and 99% (assuming that the logic solver is programmed to detect over-scale and under-scale currents) and therefore may be used up to SIL 2 as a single device.

The failure rates for the 3051S_T In-Line Pressure Transmitter are as follows:

$$\lambda^H = 59 * 10^{-9} \text{ failures per hour}$$

$$\lambda^L = 750 * 10^{-9} \text{ failures per hour}$$

$$\lambda^{DU} = 68 * 10^{-9} \text{ failures per hour}$$

Table 2 lists the failure rates for 3051S_T In-Line Pressure Transmitter according to IEC 61508, assuming that the logic solver can detect both over-scale and under-scale currents.

Table 2: Failure rates according to IEC 61508 - 3051S_T In-Line

Failure Categories	λ_{sd}	λ_{su}^*	λ_{dd}	λ_{du}	SFF
Low trip	750 FIT	468 FIT	59 FIT	68 FIT	94.9%
High trip	59 FIT	468 FIT	750 FIT	68 FIT	94.9%

(*Note that the SU category includes failures that do not cause a spurious trip)

Type B component: "Complex" component (using micro controllers or programmable logic); for details see 7.4.3.1.3 of IEC 61508-2.

The failure rates for the 3051S_C Coplanar Pressure Transmitter are as follows:

$$\lambda^H = 62 * 10^{-9} \text{ failures per hour}$$

$$\lambda^L = 777 * 10^{-9} \text{ failures per hour}$$

$$\lambda^{DU} = 73 * 10^{-9} \text{ failures per hour}$$

Table 2 lists the failure rates for 3051S_C Coplanar Pressure Transmitter with Safety Feature Board and Software Revision 3.0 according to IEC 61508, assuming that the logic solver can detect both over-scale and under-scale currents.

Table 3: Failure rates according to IEC 61508 - 3051S_C Coplanar

Failure Categories	λ_{sd}	λ_{su}^*	λ_{dd}	λ_{du}	SFF
Low trip	777 FIT	448 FIT	62 FIT	73 FIT	94.6%
High trip	66 FIT	448 FIT	777 FIT	73 FIT	94.6%

(*Note that the SU category includes failures that do not cause a spurious trip)

These failure rates are valid for the useful lifetime of the product, which is > 50 years.

A user of the 3051S SIS Pressure Transmitter with Safety Feature Board and Software Revision 3.0 can utilize these failure rates in a probabilistic model of a safety instrumented function (SIF) to determine suitability in part for safety instrumented system (SIS) usage in a particular safety integrity level (SIL). A full table of failure rates is presented in section 4.5 along with all assumptions.

Table of Contents

Management summary	2
1 Purpose and Scope	3
2 Project management.....	3
2.1 <i>exida.com</i>	3
2.2 Roles of the parties involved.....	3
2.3 Standards / Literature used.....	3
2.4 Reference documents.....	3
2.4.1 Documentation provided by the customer.....	3
2.4.2 Documentation generated by <i>exida.com</i>	3
3 Product Description.....	3
4 Failure Modes, Effects, and Diagnostics Analysis	3
4.1 Description of the failure categories.....	3
4.2 Methodology – FMEDA, Failure rates	3
4.2.1 FMEDA.....	3
4.2.2 Failure rates	3
4.3 Assumptions	3
4.4 Behavior of the safety logic solver	3
4.5 Results	3
5 Using the FMEDA results.....	3
5.1 Impulse line clogging	3
5.2 Converting failure rates to IEC 61508 format.....	3
5.3 PFD _{AVG} calculation 3051S SIS Pressure Transmitter	3
6 Terms and Definitions	3
7 Status of the document.....	3
7.1 Liability	3
7.2 Releases	3
7.3 Future Enhancements.....	3
7.4 Release Signatures.....	3
Appendix A: Proof tests to reveal dangerous undetected faults	3
A.1 Proof test 1.....	3
A.1 Proof test 2.....	3
Appendix B: Lifetime of critical components	3

1 Purpose and Scope

Generally three options exist when doing an assessment of sensors, interfaces and/or final elements.

Option 1: Hardware assessment according to IEC 61508

Option 1 is a hardware assessment by *exida.com* according to the relevant functional safety standard(s) like DIN V VDE 0801, IEC 61508 or EN 954-1. The hardware assessment contains a FMEDA to determine the fault behavior and the different failure rates resulting in the Safe Failure Fraction (SFF) and the average Probability of Failure on Demand (PFD_{AVG}).

This option for pre-existing hardware devices shall provide the safety instrumentation engineer with the required failure data as per IEC 61508 / IEC 61511 and does not contain any software assessment.

Option 2: Hardware assessment with proven-in-use consideration according to IEC 61508 / IEC 61511

Option 2 is an assessment by *exida.com* according to the relevant functional safety standard(s) like DIN V VDE 0801, IEC 61508 or EN 954-1. The hardware assessment contains a FMEDA to determine the fault behavior and the different failure rates resulting in the Safe Failure Fraction (SFF) and the average Probability of Failure on Demand (PFD_{AVG}). The option contains in addition an assessment of the proven-in-use demonstration of the device and its software including the modification process.

This option for pre-existing programmable electronic devices shall provide the safety instrumentation engineer with the required failure data as per IEC 61508 / IEC 61511 and justify the reduced fault tolerance requirements of IEC 61511 for sensors, final elements and other PE field devices.

Option 3: Full assessment according to IEC 61508

Option 3 is a full assessment by *exida.com* according to the relevant application standard(s) like IEC 61511 or EN 298 and the necessary functional safety standard(s) like DIN V VDE 0801, IEC 61508 or EN 954-1. The full assessment extends option 1 by an assessment of all fault avoidance and fault control measures during hardware and software development.

This option is most suitable for newly developed software based field devices and programmable controllers to demonstrate full compliance with IEC 61508 to the end-user.

This assessment shall be done according to option 1.

This document shall describe the results of the Failure Modes, Effects, and Diagnostic Analysis (FMEDA) of the 3051S SIS Pressure Transmitter. From these failure rates, the Safe Failure Fraction (SFF) and example PFD_{AVG} values are calculated.

2 Project management

2.1 *exida.com*

exida.com is one of the world's leading knowledge companies specializing in automation system safety and availability with over 100 years of cumulative experience in functional safety. Founded by several of the world's top reliability and safety experts from assessment organizations like TUV and manufacturers, *exida.com* is a partnership with offices around the world. *exida.com* offers training, coaching, project oriented consulting services, internet based safety engineering tools, detail product assurance and certification analysis and a collection of on-line safety and reliability resources. *exida.com* maintains a comprehensive failure rate and failure mode database on process equipment.

2.2 Roles of the parties involved

Rosemount Inc. Manufacturer of the 3051S SIS Pressure Transmitter

exida.com Project leader of the FMEDA

Rosemount Inc. contracted *exida.com* in November 2002 with the FMEDA and PFD_{AVG} calculation of the above-mentioned device.

2.3 Standards / Literature used

The services delivered by *exida.com* were performed based on the following standards / literature.

[N1]	IEC 61508-2: 1999	Functional Safety of Electrical/Electronic/Programmable Electronic Safety-Related Systems
[N2]	FMD-91 & FMD-97, RAC 1991, 1997	Failure Mode / Mechanism Distributions, Reliability Analysis Center. Statistical compilation of failure mode distributions for a wide range of components
[N3]	NPRD-95, RAC 1995	Nonelectronic Parts Reliability Data, Reliability Analysis Center. Statistical compilation of failure rate data, incl. mechanical and electrical sensors
[N4]	SN 29500	Failure rates of components
[N5]	US MIL-STD-1629	Failure Mode and Effects Analysis, National Technical Information Service, Springfield, VA. MIL 1629.
[N6]	Telcordia (Bellcore) Failure rate database and models	Statistical compilation of failure rate data over a wide range of applications along with models for estimating failure rates as a function of the application.
[N7]	Safety Equipment Reliability Handbook, 2003	<i>exida.com</i> L.L.C, Safety Equipment Reliability Handbook, 2003, ISBN 0-9727234-0-4
[N8]	Goble, W.M. 1998	Control Systems Safety Evaluation and Reliability, ISA, ISBN #1-55617-636-8. Reference on FMEDA methods

2.4 Reference documents

2.4.1 Documentation provided by the customer

[D1]	03151-3510, Rev AA	Schematic Drawing SIS/NON-SIS Feature Board, sheets 1 to 8
[D2]	03151-4214, Rev AA	Schematic Cosmos Supermodule Transient Terminal Block, Dual compartment sheet 1 of 1
[D3]	03151-1514, Rev AA	Schematic Coplanar Board II, 3051S sheets 1 to 5
[D4]	03151-1511. Rev AK	Schematic Cosmos Supermodule, 3051T sheets 1 to 5

2.4.2 Documentation generated by *exida.com*

[R1]	SFB FMEDA update after fault injection 020304.xls	Failure rate calculations SFB, 3051S SIS Pressure Transmitter, February 03, 2004
[R2]	SM_Coplanar FMEDA_CAN_Mode_V2R04.xls	Failure rate calculations, 3051S Pressure Transmitter Coplanar, October 3, 2003
[R3]	SM_Inline FMEDA_CAN_Mode_V2R03.xls	Failure rate calculations, 3051S Pressure Transmitter In-Line, October 3, 2003
[R4]	3051S SIS Summary 06Feb04.xls	FMEDA Summary sheet 3051S SIS Pressure Transmitter, February 06, 2004
[R5]	Ros 02-11-07 R001 V230.doc	FMEDA report, 3051S SIS Pressure Transmitter, December 17, 2004

3 Product Description

The 3051S SIS Pressure Transmitter is a two-wire, 4 – 20 mA smart device. It contains self-diagnostics and is programmed to send it's output to a specified failure state, either high or low upon internal detection of a failure. This report assumes that the jumper is set to send the output low.

For safety instrumented systems usage it is assumed that the 4 – 20 mA output is used as the primary safety variable. All other possible output variants are not covered by this report. The different devices can be equipped with or without display. Table 1 gives an overview of the two versions of the 3051S SIS Pressure Transmitter with Safety Feature Board and Software Revision 3.0 that were considered for this FMEDA analysis.

Table 4: Version overview

3051S_T In-Line	3051S In-Line Pressure Transmitter
3051S_C Coplanar	3051S Coplanar Pressure Transmitter

Figure 1 gives a graphical representation of the 3051S SIS Pressure Transmitter.

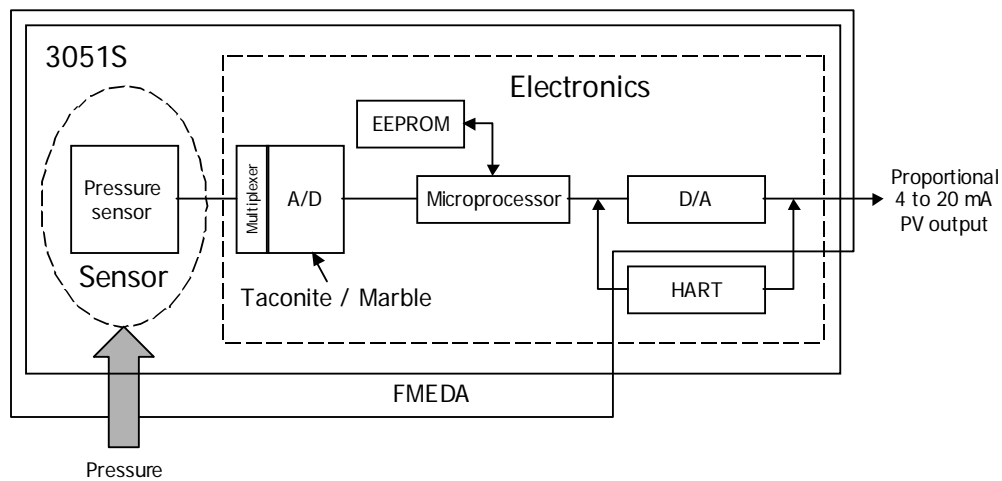

Figure 1 3051S SIS Pressure Transmitter

The 3051S SIS Pressure Transmitter is classified as a Type B² device according to IEC61508, having a hardware fault tolerance of 0.

The pressure transmitter can be connected to the process using an impulse line, depending on the application the clogging of the impulse line needs to be accounted for.

Type B component: "Complex" component (using micro controllers or programmable logic); for details see 7.4.3.1.3 of IEC 61508-2.

4 Failure Modes, Effects, and Diagnostics Analysis

The Failure Modes, Effects, and Diagnostic Analysis was based on documentation provided by Rosemount Inc. and is documented in [R1] and [R5]. When the effect of a certain failure mode could not be analyzed theoretically, the failure modes were introduced on component level and the effects of these failure modes were examined on system level.

4.1 Description of the failure categories

In order to judge the failure behavior of the 3051S SIS Pressure Transmitter with Safety Feature Board and Software Revision 3.0, the following definitions for the failure of the product were considered.

Fail-Safe State	Depending on the application the fail-safe state is defined as the output going to fail low or fail high.
Fail Safe	Failure that causes the module / (sub)system to go to the defined fail-safe state without a demand from the process. Safe failures are divided into safe detected (SD) and safe undetected (SU) failures.
Fail Dangerous	Failure that deviates the measured input state or the actual output by more than 2% of span and that leaves the output within active scale (including frozen output).
Fail Dangerous Undetected	Failure that is dangerous and that is not being diagnosed by internal diagnostics.
Fail Dangerous Detected	Failure that is dangerous but is detected by internal diagnostics (These failures may be converted to the selected fail-safe state).
Fail High	Failure that causes the output signal to go to the maximum output current (> 21,5 mA, output saturate high)
Fail Low	Failure that causes the output signal to go to the minimum output current (< 3,6 mA, output saturate low)
Fail No Effect	Failure of a component that is part of the safety function but that has no effect on the safety function.
Annunciation Undetected	Failure that does not directly impact safety but does impact the ability to detect a future fault (such as a fault in a diagnostic circuit) and that is not detected by internal diagnostics.

The failure categories listed above expand on the categories listed in [N1] which are only safe and dangerous, both detected and undetected. The reason for this is that, depending on the application, a Fail High or a Fail Low can either be safe or dangerous and may be detected or undetected depending on the programming of the logic solver. Consequently, during a Safety Integrity Level (SIL) verification assessment the Fail High and Fail Low failure categories need to be classified as either safe or dangerous.

The Annunciation Undetected failures are provided for those who wish to do reliability modeling more detailed than required by IEC61508. In IEC 61508 [N1] the No Effect and Annunciation Undetected failures are defined as safe undetected failures even though they will not cause the safety function to go to a safe state. Therefore they need to be considered in the Safe Failure Fraction calculation.

4.2 Methodology – FMEDA, Failure rates

4.2.1 FMEDA

A Failure Modes and Effects Analysis (FMEA) is a systematic way to identify and evaluate the effects of different component failure modes, to determine what could eliminate or reduce the chance of failure, and to document the system in consideration.

An FMEDA (Failure Mode Effect and Diagnostic Analysis) is an FMEA extension. It combines standard FMEA techniques with extension to identify online diagnostics techniques and the failure modes relevant to safety instrumented system design. It is a technique recommended to generate failure rates for each important category (safe detected, safe undetected, dangerous detected, dangerous undetected, fail high, fail low) in the safety models. The format for the FMEDA is an extension of the standard FMEA format from MIL STD 1629A, Failure Modes and Effects Analysis.

4.2.2 Failure rates

The failure rate data used by *exida.com* in this FMEDA is from a proprietary component failure rate database derived using the Telcordia (N6) failure rate database/models, the SN29500 (N4) failure rate database and other sources. The rates were chosen in a way that is appropriate for safety integrity level verification calculations. The rates were chosen to match operating stress conditions typical of an industrial field environment similar to IEC 645-1, Class C. It is expected that the actual number of field failures will be less than the number predicted by these failure rates.

The user of these numbers is responsible for determining their applicability to any particular environment. Accurate plant specific data may be used for this purpose. If a user has data collected from a good proof test reporting system that indicates higher failure rates, the higher numbers shall be used. Some industrial plant sites have high levels of stress. Under those conditions the failure rate data is adjusted to a higher value to account for the specific conditions of the plant.

4.3 Assumptions

The following assumptions have been made during the Failure Modes, Effects, and Diagnostic Analysis of the 3051S SIS Pressure Transmitter.

- Only a single component failure will fail the entire product
- Failure rates are constant, wear out mechanisms are not included.
- Propagation of failures is not relevant.
- All components that are not part of the safety function and cannot influence the safety function (feedback immune) are excluded.
- The HART protocol is only used for setup, calibration, and diagnostics purposes, not for safety critical operation.
- The application program in the logic solver is constructed in such a way that Fail High and Fail Low failures are detected regardless of the effect, safe or dangerous, on the safety function.
- The 3051S SIS Pressure Transmitter is programmed to send it's output low upon internal detection of a failure; this is advised to avoid dangerous failures at low compliance voltages

- The stress levels are average for an industrial environment and can be compared to the Ground Fixed classification of MIL-HNBK-217F. Alternatively, the assumed environment is similar to:
 - IEC 645-1, Class C (sheltered location) with temperature limits within the manufacturer's rating and an average temperature over a long period of time of 40°C. Humidity levels are assumed within manufacturer's rating.
- External power supply failure rates are not included.

4.4 Behavior of the safety logic solver

Depending on the application, the following scenarios are possible:

- Low Trip: the safety function will go to the predefined fail-safe state when the process value below a predefined low set value. A current < 3.6mA (Fail Low) is below the specified trip-point.
- High Trip: the safety function will go to the predefined fail-safe state when the process value exceeds a predefined high set value. A current > 21.5mA (Fail High) is above the specified trip-point.

The Fail Low and Fail High failures can either be detected or undetected by a connected logic solver. The PLC Detection Behavior in Table 5 represents the under-range and over-range detection capability of the connected logic solver.

Table 5 Application example

Application	PLC Detection Behavior	λ_{low}	λ_{high}
Low trip	< 4mA	= λ_{sd}	= λ_{du}
Low trip	> 20mA	= λ_{su}	= λ_{dd}
Low trip	< 4mA and > 20mA	= λ_{sd}	= λ_{dd}
Low trip	-	= λ_{su}	= λ_{du}
High trip	< 4mA	= λ_{dd}	= λ_{su}
High trip	> 20mA	= λ_{du}	= λ_{sd}
High trip	< 4mA and > 20mA	= λ_{dd}	= λ_{sd}
High trip	-	= λ_{du}	= λ_{su}

In this analysis it is assumed that the logic solver is able to detect under-range and over-range currents, therefore the yellow highlighted behavior is assumed.

4.5 Results

Using reliability data extracted from the exida.com component reliability database the following failure rates resulted from the 3051S SIS Pressure Transmitter FMEDA, In-Line and Coplanar version.

Table 6 Failure rates 3051S_T In-Line Pressure Transmitter

Failure category		Failure rate (in FITs)	
Fail High (detected by the logic solver)		59	
Fail Low (detected by the logic solver)		750	
	Fail detected (int. diag.)	470	
	Fail low (inherently)	280	
Fail Dangerous Undetected		68	
No Effect		437	
Annunciation Undetected		31	

Table 7 Failure rates 3051S_C Coplanar Pressure Transmitter

Failure category		Failure rate (in FITs)	
Fail High (detected by the logic solver)		62	
Fail Low (detected by the logic solver)		777	
	Fail detected (int. diag.)	500	
	Fail low (inherently)	277	
Fail Dangerous Undetected		73	
No Effect		409	
Annunciation Undetected		39	

As it is assumed that upon the detection of a failure the output will be sent downscale, all detected failure categories are sub-categories of the Fail Low failure category. When the transmitter is configured to send the output over-range on detection of a failure, all detected failures would be a sub-category of the Fail High failure category.

According to IEC 61508 [N1], the Safe Failure Fraction (SFF) of the 3051S SIS Pressure Transmitter should be calculated. The SFF is the fraction of the overall failure rate of a device that results in either a safe fault or a diagnosed unsafe fault. As both the Fail High and Fail Low failure categories are assumed to be detected by the logic solver (regardless of the fact if their effect is safe or dangerous), the Safe Failure Fraction can be calculated independently of the 3051S SIS Pressure Transmitter application.

This is reflected in the following formulas for SFF:

$$SFF = 1 - \lambda_{du} / \lambda_{total}$$

Note that according to IEC61508 definition the No Effect and Annunciation Undetected failures are classified as safe and therefore need to be considered in the Safe Failure Fraction calculation and are included in the total failure rate.

Table 8 Safe Failure Fraction of 3051S SIS Pressure Transmitter

3051S SIS Pressure Transmitter	SFF
3051S_T In-Line Pressure Transmitter	94.9%
3051S_C Coplanar Pressure Transmitter	94.6%

The architectural constraint type for 3051S SIS Pressure Transmitter, with Safety Feature Board and Software Revision 3.0, is B. The SFF and required SIL determine the level of hardware fault tolerance that is required per requirements of IEC 61508 [N1] or IEC 61511. The SIS designer is responsible for meeting other requirements of applicable standards for any given SIL as well.

5 Using the FMEDA results

5.1 Impulse line clogging

The 3051S SIS Pressure Transmitter failure rates that are displayed in section 4.5 are failure rates that reflect the situation where the transmitter is used in clean service. Clean service indicates that failure rates due to clogging of the impulse line are not counted. For applications other than clean service, the user must estimate the failure rate for the clogged impulse line and add this failure rate to the 3051S SIS Pressure Transmitter failure rates.

5.2 Converting failure rates to IEC 61508 format

The failure rates that are derived from the FMEDA for the 3051S SIS Pressure Transmitter with Safety Feature Board and Software Revision 3.0 are in a format different from the IEC 61508 format. This section will explain how the failure rates can be converted into the IEC 61508 format.

Depending on the application, the high and low failures of the 3051S SIS Pressure Transmitter must be classified as either safe or dangerous (see also Section 4.4). Assume an application where a safety action needs to be performed if the pressure in a pipe drops below a certain level. The transmitter will therefore be configured with a low trip level. A low failure of the transmitter will cause the transmitter output to go through the low trip level. Consequently the transmitter will indicate that the safety action needs to be performed. Therefore a low failure can be classified as a safe failure for this application. A high failure on the other hand will cause the transmitter output to move away from the trip level and therefore not cause a trip. The failure will prevent the transmitter from indicating that the safety action needs to be performed and is therefore classified as a dangerous failure for this application.

Assuming that the logic solver can detect both over-range and under-range, a low failure can be classified as a safe detected failure and a high failure can be classified as a dangerous detected failure. The failure rates for the 3051S_T In-Line Pressure Transmitter would then be:

$$\lambda^H = \lambda^{DD} = 59 * 10^{-9} \text{ failures per hour}$$

$$\lambda^L = \lambda^{SD} = 750 * 10^{-9} \text{ failures per hour}$$

$$\lambda^{DU} = 68 * 10^{-9} \text{ failures per hour}$$

For this application the failure rates for the 3051S_C Coplanar Pressure Transmitter would be:

$$\lambda^H = \lambda^{DD} = 62 * 10^{-9} \text{ failures per hour}$$

$$\lambda^L = \lambda^{SD} = 777 * 10^{-9} \text{ failures per hour}$$

$$\lambda^{DU} = 73 * 10^{-9} \text{ failures per hour}$$

In a similar way the high and low failure rates can be classified as respectively safe detected and dangerous detected in case the application has a high trip level. The failure rates as displayed above are the same failure rates as stored in the exida.com equipment database that is part of the online SIL verification tool, SILver.

Furthermore the No Effect failures and Annunciation Undetected failure are classified as Safe Undetected failures according to IEC 61508. Note that these failures will not affect system reliability or safety, and should not be included in spurious trip calculations.

Note that the dangerous undetected failures will of course remain dangerous undetected.

5.3 PFD_{AVG} calculation 3051S SIS Pressure Transmitter

An average Probability of Failure on Demand (PFD_{AVG}) calculation is performed for a single (1oo1) 3051S SIS Pressure Transmitter with Safety Feature Board and Software Revision 3.0. The failure rate data used in this calculation is displayed in section 4.5.

The PFD_{AVG} values for the 3051S_T In-Line Pressure Transmitter, for a variety of proof test intervals are displayed in Figure 2. As shown in the figure the PFD_{AVG} value for a single 3051S_T In-Line Pressure Transmitter with a proof test interval of 1 year equals 2.98E-04.

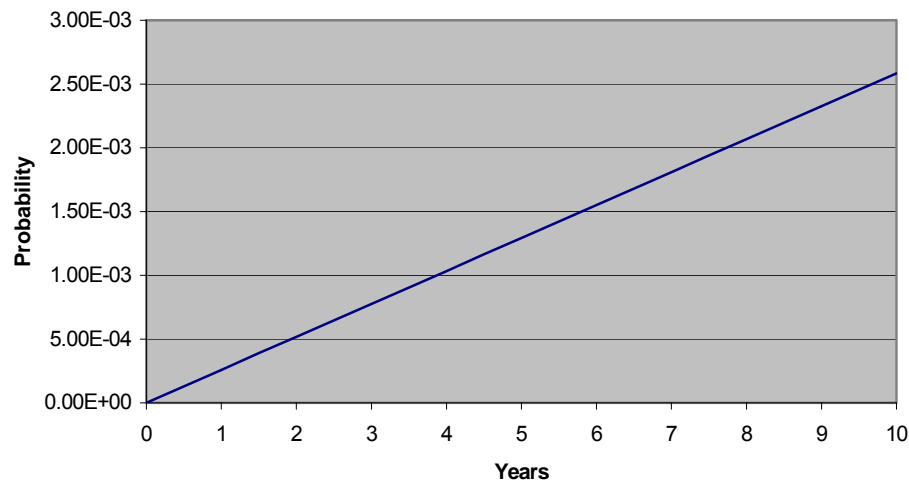

Figure 2: PFD_{AVG}(t) 3051S_T In-Line Pressure Transmitter

The PFD_{AVG} values for the 3051S_C Coplanar Pressure Transmitter, for a variety of proof test intervals are displayed in Figure 3. As shown in the figure the PFD_{AVG} value for a single 3051S_C Coplanar Pressure Transmitter with a proof test interval of 1 year equals 3.20E-04.

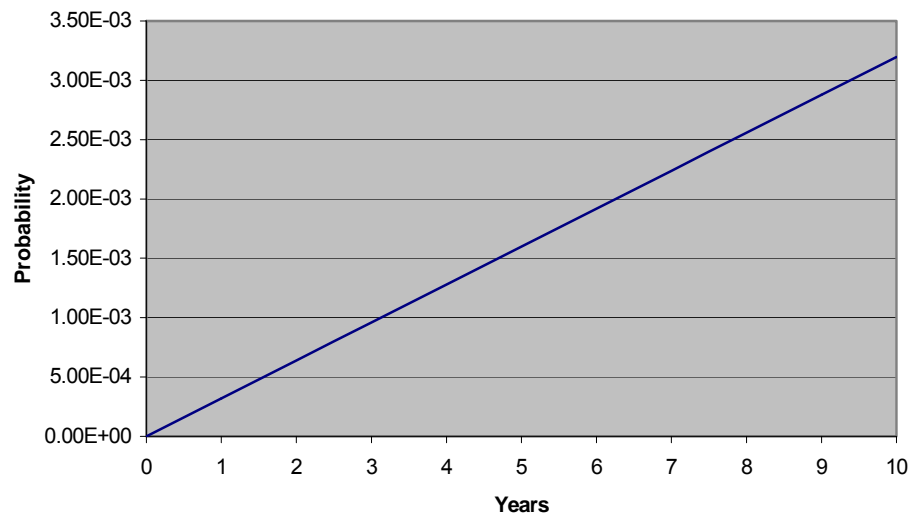

Figure 3 PFD_{AVG}(t) 3051S_C Coplanar Pressure Transmitter

For SIL 2 applications, the PFD_{AVG} value needs to be $\geq 10^{-3}$ and $< 10^{-2}$. This means that for a SIL 2 application, the PFD_{AVG} for a 1-year Proof Test Interval of the 3051S_T In-Line Pressure Transmitter, is equal to 2.58% of the range and for the 3051S_C Coplanar Pressure Transmitter is equal to 3.2 % of the range.

These results must be considered in combination with PFD_{AVG} values of other devices of a Safety Instrumented Function (SIF) in order to determine suitability for a specific Safety Integrity Level (SIL).

6 Terms and Definitions

FIT	Failure In Time (1×10^{-9} failures per hour)
FMEDA	Failure Mode Effect and Diagnostic Analysis
HART	Highway Addressable Remote Transducer
HFT	Hardware Fault Tolerance
Low demand mode	Mode, where the frequency of demands for operation made on a safety-related system is no greater than one per year and no greater than twice the proof test frequency.
PFD_{AVG}	Average Probability of Failure on Demand
SFF	Safe Failure Fraction summarizes the fraction of failures, which lead to a safe state and the fraction of failures that will be detected by diagnostic measures and lead to a defined safety action.
SIF	Safety Instrumented Function
SIL	Safety Integrity Level
SIS	Safety Instrumented System – Implementation of one or more Safety Instrumented Functions. A SIS is composed of any combination of sensor(s), logic solver(s), and final element(s).
Type A component	“Non-Complex” component (using discrete elements); for details see 7.4.3.1.3 of IEC 61508-2
Type B component	“Complex” component (using micro controllers or programmable logic); for details see 7.4.3.1.3 of IEC 61508-2

7 Status of the document

7.1 Liability

exida.com prepares FMEDA reports based on methods advocated in International standards. Failure rates are obtained from a collection of industrial databases. *exida.com* accepts no liability whatsoever for the use of these numbers or for the correctness of the standards on which the general calculation methods are based.

7.2 Releases

Version: V2
Revision: R4
Version History: V2, R4: Clarify product revision; August 27, 2007
V2, R3.0: Updated typo in PFD_{AVG} value, December 17, 2004
V2, R2.0: Updated data after Fault Injection Testing, February 6, 2004
V2, R1.0: Updated data after HW change, December 18, 2003
V1, R1.1: Updated product name, November 14, 2003
V1, R1.0: Released to client, October 03, 2003
V0, R1.0: Draft; September 26, 2003
Authors: William M. Goble – John C. Grebe
Review: V0, R1.0: William M. Goble, *exida.com*
V1, R1.0: Rachel Amkreutz, *exida.com*
Release status: Released to client

7.3 Future Enhancements

At request of client.

7.4 Release Signatures

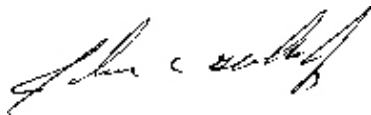

John C. Grebe Jr., Principal Engineer



Dr. William M. Goble, Principal Partner

Appendix A: Proof tests to reveal dangerous undetected faults

According to section 7.4.3.2.2 f) of IEC 61508-2 proof tests shall be undertaken to reveal dangerous faults which are undetected by diagnostic tests. This means that it is necessary to specify how dangerous undetected faults which have been noted during the FMEDA can be detected during proof testing.

A.1 Proof test 1

Proof test 1 consists of the following steps, as described in Table 9.

Table 9 Steps for Proof Test 1

Step	Action
1	Bypass the safety PLC or take other appropriate action to avoid a false trip
2	Send a HART command to the transmitter to go to the high alarm current output and verify that the analog current reaches that value. This tests for compliance voltage problems such as a low loop power supply voltage or increased wiring resistance. This also tests for other possible failures.
3	Send a HART command to the transmitter to go to the low alarm current output and verify that the analog current reaches that value. This tests for possible quiescent current related failures
4	Restore the loop to full operation
5	Remove the bypass from the safety PLC or otherwise restore normal operation

This test will detect approximately 50% of possible DU failures in the transmitter.

A.1 Proof test 2

Proof test 1 consists of the following steps, as described in Table 10.

Table 10 Steps for Proof Test 2

Step	Action
1	Bypass the safety PLC or take other appropriate action to avoid a false trip
2	Perform Proof Test 1
3	Perform a two-point calibration of the transmitter
4	Restore the loop to full operation
5	Remove the bypass from the safety PLC or otherwise restore normal operation

This test will detect approximately 99% of possible DU failures in the transmitter.

Appendix B: Lifetime of critical components

Although a constant failure rate is assumed by the probabilistic estimation method (see section 4.3) this only applies provided that the useful lifetime of components is not exceeded. Beyond their useful lifetime the result of the probabilistic calculation method is therefore meaningless, as the probability of failure significantly increases with time. The useful lifetime is highly dependent on the component itself and its operating conditions – temperature in particular (for example, electrolyte capacitors can be very sensitive).

This assumption of a constant failure rate is based on the bathtub curve, which shows the typical behavior for electronic components.

Therefore it is obvious that the PFD_{AVG} calculation is only valid for components that have this constant domain and that the validity of the calculation is limited to the useful lifetime of each component.

Table 11 shows which electrolytic capacitors are contributing to the dangerous undetected failure rate and therefore to the PFD_{AVG} calculation and what their estimated useful lifetime is.

Table 11: Useful lifetime of electrolytic capacitors contributing to λ_{du}

Type	Useful life at 40°C
Capacitor (electrolytic) - Tantalum electrolytic, solid electrolyte	Appr. 500 000 hours

As the capacitors are the limiting factors with regard to the useful lifetime of the system, the useful lifetime should be limited to 50 years.