

Process Leak Detection Diagnostic with Intelligent Differential Pressure Transmitter

The use of impulse lines, manifolds and bleed valves in measurement instrumentation process connections is a universal practice. Over time these connections may degrade due to vibration, temperature changes, wear, damage or neglect resulting in process leaks.

Traditionally, identifying these leaks requires specialized and expensive equipment or frequent and costly visual inspections. In many installations, transmitters are located in remote or restricted areas where a leak could go undetected for extended periods of time. This, in turn, translates into higher operating costs, lost product, negative impacts to the environment and also places personnel at risk for injury.

The Rosemount 3051S with Advanced Diagnostics provides real-time detection of process leaks anywhere in the impulse line system. This ability offers the end user another method of measurement verification, improved maintenance response time and enhanced workplace safety.

Background

Emerson Process Management's Rosemount division developed a new generation of Differential Pressure transmitters with a unique, scalable architecture. This new pressure transmitter platform, called the Rosemount 3051S, provides best in class performance and reliability and also feature advancements in power management that allow the easy addition of advanced functionality to the base pressure transmitter. This functionality, embodied in a feature board, can be ordered as part of the transmitter or simply added to an existing transmitter already installed in the field.

Making use of this advanced functionality, Emerson Process Management has developed a unique patented technology that provides a means for early detection of abnormal situations in a process environment. The technology, called Statistical Process Monitoring (SPM), is based on the premise that virtually all dynamic processes have a unique noise or variation signature under normal operation. Changes in these signatures may signal that a significant change in the process, process equipment, or transmitter installation will occur or has occurred. For example, the noise source may be equipment in the process such

as pumps, agitators or the natural variation in the DP value caused by turbulent flow or any combination thereof.

The sensing of the unique signature begins with a high speed sensing device such as the Rosemount 3051S Pressure Transmitter equipped with patented software resident in a HART Diagnostics or Foundation Fieldbus Feature Board. This powerful combination has the ability to compute statistical parameters that characterize and quantify the noise or variation and represent the mean and standard deviation of the input pressure. Filtering capability is provided to separate slow changes in the process due to intentional setpoint changes from inherent process noise which contains the variation of interest.

The transmitter provides the statistical parameters to the host system via HART or Foundation Fieldbus communications as non-primary variables enabling quick and straightforward historization of the process characteristics. DCS limits on the imported statistical process variables may be established through several techniques. Initial limits may be created solely based on previous experience and process expert input. Often these limits are fairly generous and are mainly intended to detect severe process anomalies. Further refinement of the DCS limits are then made through observation of typical process variation related to variables such as seasonality, fluctuating customer demand or varying incoming material lot characteristics as examples.

In many applications, process limits may be accurately generated by safely simulating an abnormal situation. As conditions allow, process issues like plugged impulse lines, aerated liquid, loss of agitation or impulse line leaks can be intentionally created. From this abnormal situation exercise, the resulting process variables would be used to exactly define the DCS control limits.

The transmitter also has internal software that can be used to baseline the process noise or signature via a defined learning process. Once the learning process is completed, the device itself can detect changes in process noise and will communicate an alarm via the 4 – 20 mA output or alert via HART or Foundation Fieldbus.

With the design of this transmitter and feature board complete, Emerson initiated a test program to determine if this technology could be applied to the prediction of square root error in DP flow applications.

Test Program Description

The ability to predict impulse system leaks was evaluated on Rosemount's Dynamic Flow Loop using a 3051S DP transmitter equipped with a DA1 (HART Advanced Diagnostics Feature Board). Independent measurement of the process dynamics was obtained through a pair of high speed pressure transducers connected to a frequency analyzer. A diagram of the test setup is illustrated in Figure 1.

Figure 1 – Test Configuration

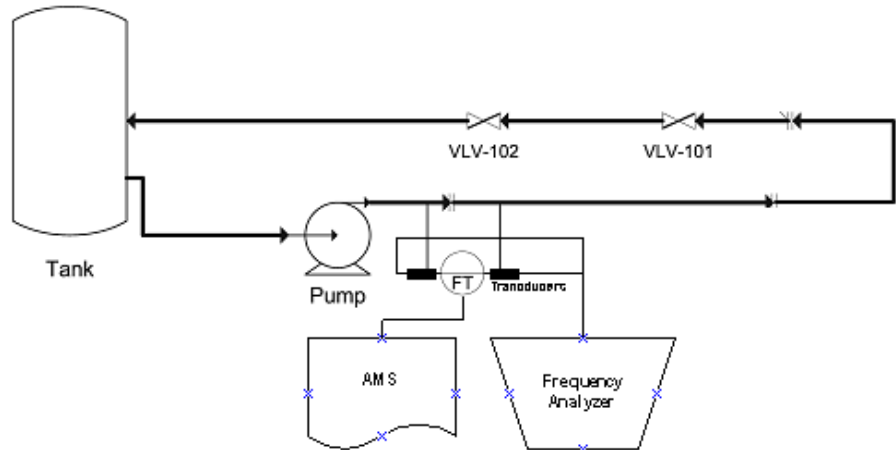

Testing consisted of running the Flow Loop at two pump speeds then initiating controlled leaks along the impulse lines and at the bleed valves. Figure 2 shows the apparatus designed and built specifically for this testing.

Figure 2 – Controlled Impulse Line Leak Test Setup



The data represented in Figures 3, 4 and 6 were taken while the pump was running at 1850 RPM. This generated an initial DP of approximately 50 inH₂O across a 0.45β orifice plate with a corresponding standard deviation value of 0.18 inH₂O. Once flow conditions had stabilized, a 0.35 gallon per minute leak was created on the low side impulse line. Immediately, the standard deviation

responded by shifting to the new value of 0.24 inH₂O. Simultaneously, the DP mean moved to 63 inH₂O, an anticipated change since this test was performed under constant flow conditions. Note that the time scales for the two graphs shown in Figure 3 are not synchronized to the same horizontal axis. The observed changes did occur at the same point in time at approximately 10:50:30.

Figure 3 – 0.35 GPM leak from the low side impulse line

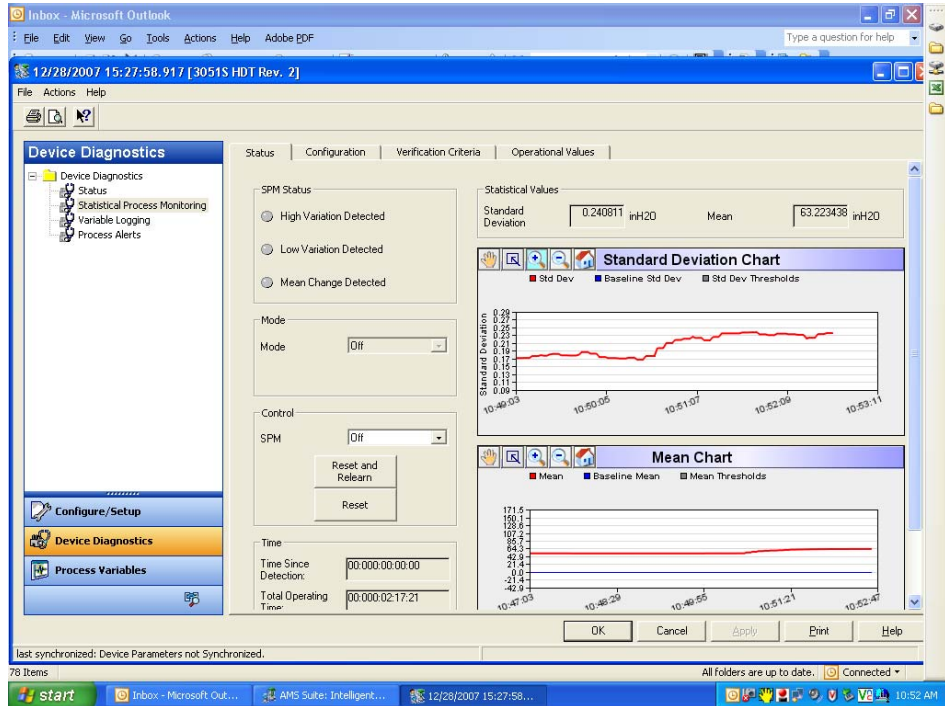

In order to better understand the underlying, physical contribution to these observed changes, two high speed pressure transducers were installed into the pressure manifold, replacing the process bleed valves. The conditions described above were replicated and the resulting process frequency data was collected and analyzed. The data set is provided in Figure 4.

Figure 4 – High Speed Transducer Frequency Analysis for Low Side Impulse Line Leak at 1850 RPM

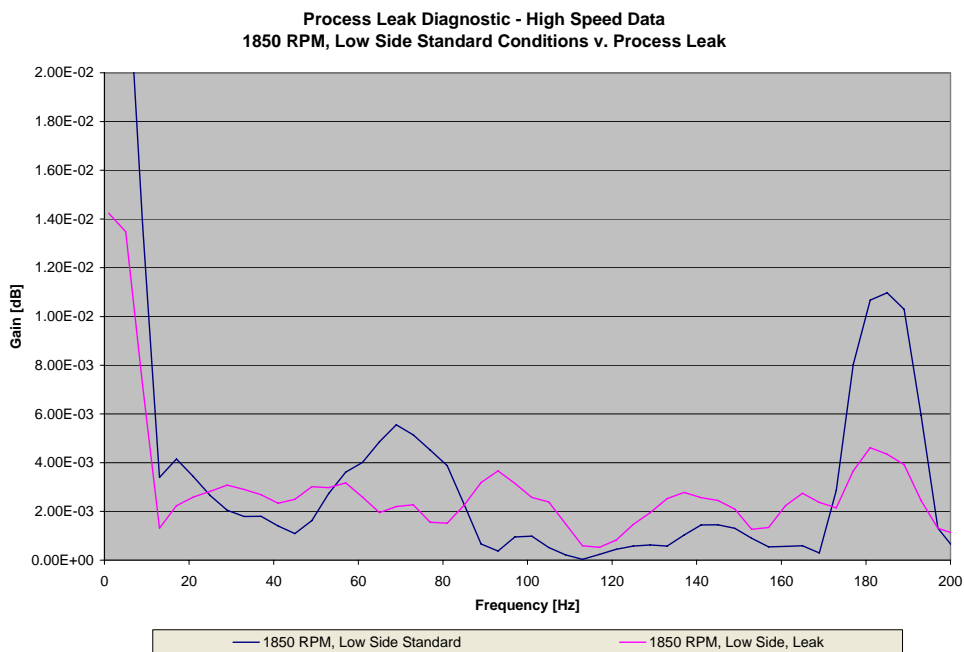

A clear change in process dynamics were observed between the standard conditions and during the presence of a leak. As seen, several frequencies of interest stand out. The first and most prominent is the set of peaks associated with 185 Hz. Recall, for this test, the pump was set to 1850 RPM. This particular pump has a six vane impeller and as a result, creates a frequency disturbance 1/10 of its operating speed. The secondary peak, near 65 Hz is a harmonic of the 185 Hz pump output.

A similar set of frequencies and amplitudes were observed when testing the process dynamics on the high side of the transmitter.

From earlier research, it has been demonstrated that process noise due to pumps, valves and fluid flow are experienced by both the high and low side of the transmitter in nearly the same time domain. These types of process dynamics have been dubbed “common mode” and routinely cancel each other out during normal operating conditions. Figure 5a illustrates this effect.

Figures 5a – Common Mode Dynamics Standard Conditions and with Leak Present

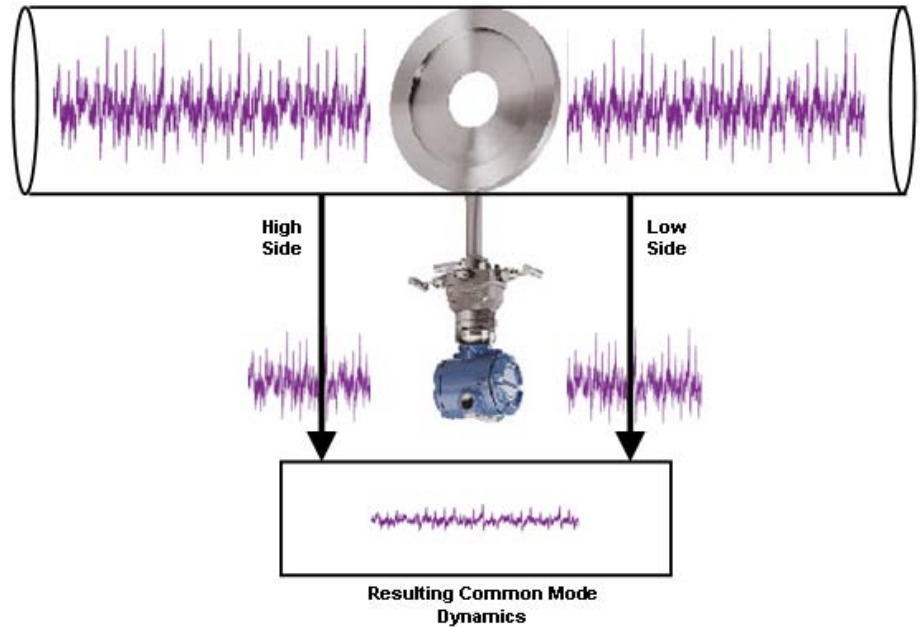

Figures 5b

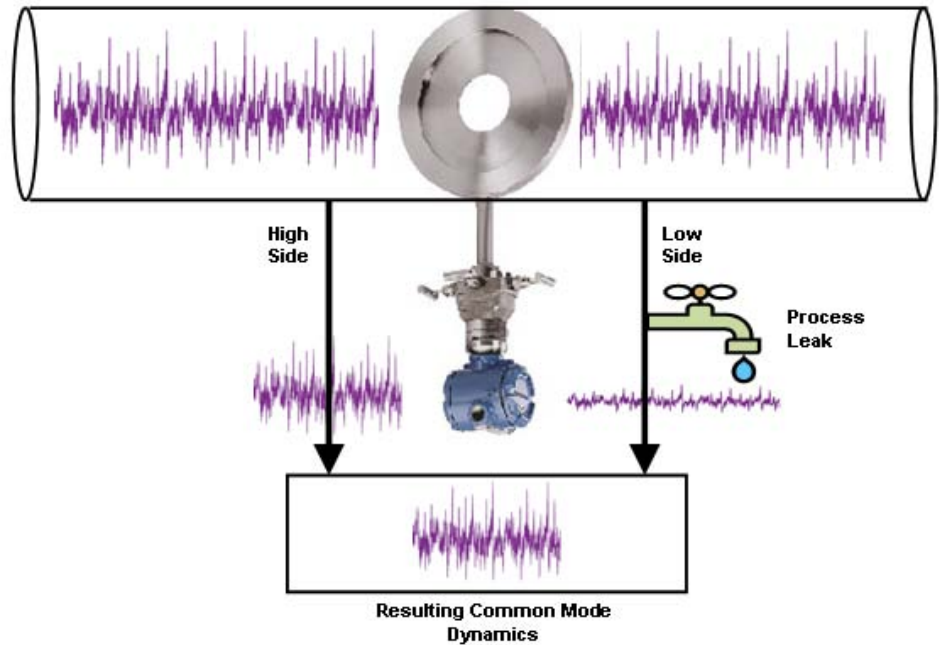

When a leak develops, the large peaks associated with pump operation are substantially attenuated. This attenuation only occurs on the side where a leak is present, while the other side remains in close, dynamic contact with the process. The common mode conditions, as seen in Figure 5b, are no longer met and the dynamics between the high and low side become imbalanced. The transmitter experiences this as an overall increase in the process noise and reports an increase in the standard deviation as shown in Figures 3 and 6.

The same set of principles described above applies to leaks due to open or leaking bleed valves, leaking manifold gaskets or failed fittings located along the impulse lines. This was illustrated by opening a bleed valve on the low pressure side of the manifold and collecting the data presented in Figure 6. Again, the standard deviation increased due to the imbalance in common mode process dynamics.

Figure 6 – Process Data due to a leak located on the low pressure side manifold bleed valve

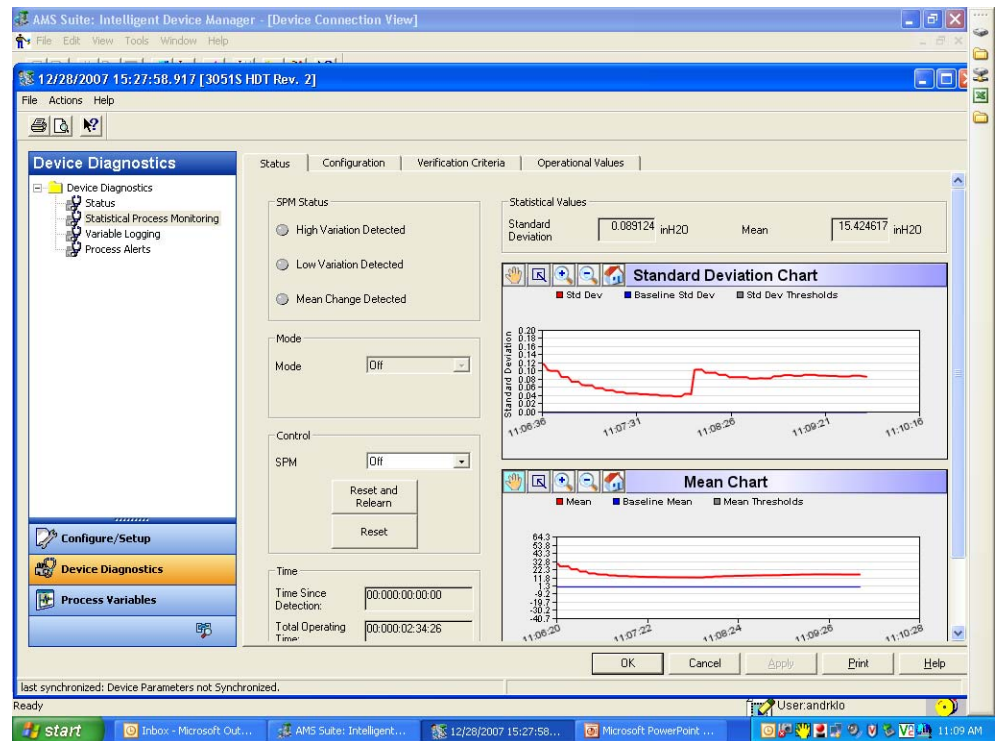

Conclusion

Providing the end user with an accurate and reliable PV along with a real-time indication of the integrity of the process measurement is a very powerful combination. A Rosemount 3051S with Advanced Diagnostics is capable of detecting process leaks at the bleed valves, at the manifold and along the impulse lines. A leak at any of these points changes the level of process dynamics as measured by the pressure transmitter. This change in dynamics is reflected to the user as a drift or a shift in standard deviation.

Secondary or supporting evidence of a process leak is available by monitoring the pressure mean (average) variable. A leak, having gone undetected and worsening with time, will directly affect the pressure mean value. In a LP application, mean will always decrease with the presence of a leak as line pressure is no longer being completely contained. In a DP application with fixed flow rate, mean will increase or decrease depending on which side (high or low) the leak has occurred.

Using the standard deviation and mean process variables in tandem makes for a clear method for process leak detection. The instantaneous feedback from the transmitter allows for quick maintenance response, reducing lost product and improving safety.

Other resources

- The Rosemount 3051S is the first scalable pressure transmitter that provides a foundation for integrated pressure, flow, and level solutions. <http://www.Rosemount.com/3051S>
- The Rosemount product offering includes a complete line of pressure, temperature, flow, level, and safety measurement instrumentation. www.Rosemount.com

The contents of this publication are presented for informational purposes only, and while effort has been made to ensure their accuracy, they are not to be construed as warranties or guarantees, express or implied, regarding the products or services described herein or their use or applicability. All sales are governed by our terms and conditions, which are available on request. We reserve the right to modify or improve the designs or specifications of our products at any time without notice.

Rosemount and the Rosemount logotype are registered trademarks of Rosemount Inc. All other marks are the property of their respective owners.

Emerson Process Management

Rosemount Inc.
8200 Market Boulevard
Chanhassen, MN 55317 USA
T (U.S.) 1-800-999-9307
T (International) (952) 906-8888
F (952) 949-7001

www.rosemount.com