

REVISIONS				
REV	DESCRIPTION	CHG.NO.	APP'D	DATE
AB	REMOVED SNAP-RING HOLDER	DSI1002683	MH	06/24/09

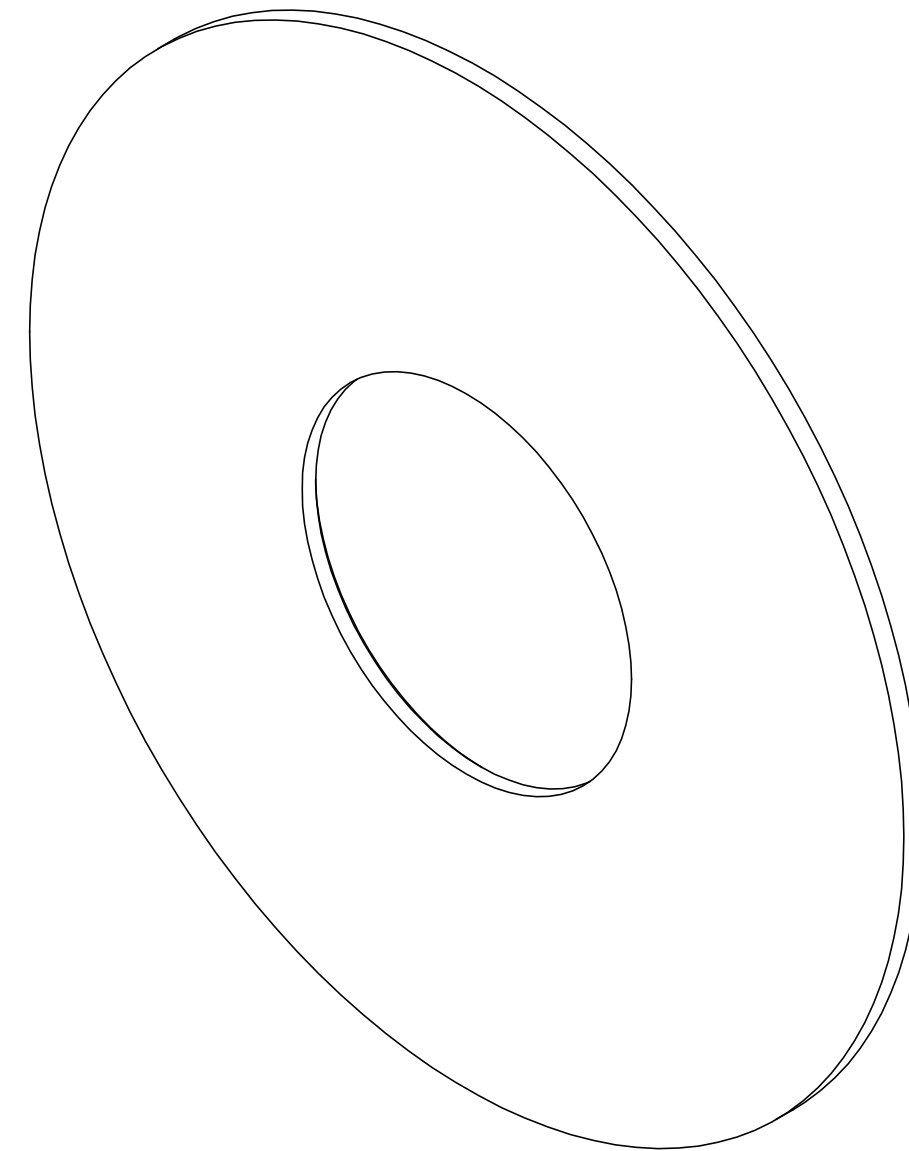

NOTES:

1. ROSEMOUNT INC. CERTIFIES THIS DRAWING IS IN ACCORDANCE WITH ROSEMOUNT ENGINEERING SPECIFICATIONS AND ACCURATELY REPRESENTS THE EQUIPMENT FURNISHED.
2. ORIFICE PLATE ORIENTATION SHOWN FOR DETAIL ONLY. FOR ACTUAL RECOMMENDED LOCATION AND ORIENTATION REFER TO INSTALLATION INSTRUCTION MANUAL 00809-0100-4792 AND PAGE 14 OF THIS DOCUMENT.
3. FOR MODEL SELECTIONS, MATERIALS, AND OPTIONS, REFER TO ROSEMOUNT PRODUCT DATA SHEET 00813-0100-4792.
4. MODEL 1495 MAXIMUM TEMPERATURE IS 850°F (OBSERVE GASKET MATERIAL TEMPERATURE LIMITATIONS).
5. ORIFICE FLANGES, STUDS, NUTS AND GASKETS ARE NOT INCLUDED WITH MODEL 1495.
6. PLATE HOLDERS MUST BE SPECIFIED BY ORDERING THE PLATE HOLDER OPTION

*UNLESS OTHERWISE SPECIFIED DIMENSIONS IN INCHES (MM)		<b>TYPE I</b>		<b>ROSEMOUNT®</b> BOULDER, COLORADO		
*ALL DIMENSIONS ARE NOMINAL AND ARE FOR REFERENCE ONLY		DR. DMK	11/13/03	TITLE DIMENSIONAL DRAWING FOR MODEL 1495 UNIVERSAL ORIFICE PLATE		
		APPROVAL		SIZE	DRAWING NO.	
		DRAWING	K. GREEN	12/20/03	C	01495-1003
		TAGGING			SCALE: NONE	
		SPECIALS			SHEET 1 OF 14	

TABLE 1 UNIVERSAL PLATE DIMENSIONS		
LINE SIZE	'ØA' (OD)	'B' (DEFAULT THICKNESS)
2"	2.44	0.13
2-1/2"	2.81	0.13
3"	3.44	0.13
4"	4.41	0.13
6"	6.44	0.13
8"	8.44	0.25
10"	10.69	0.25
12"	12.59	0.38
14"	14.00	0.38
16"	16.00	0.38
18"	18.00	0.38
20"	20.00	0.38
24"	24.00	0.38

TABLE 2												
LINE SIZE	FLANGE RATING											
	150#				300#				600#			
	Ring No.	C	D	E	Ring No.	C	D	E	Ring No.	C	D	E
2" (DN 50)	R-22	3.56	5.50	1.06	R-23	3.69	5.50	1.06	R-23	3.69	5.50	1.06
2-1/2" (DN 65)	R-25	4.31	6.50	1.06	R-26	4.44	6.50	1.06	R-26	4.44	6.50	1.06
3" (DN 80)	R-29	4.81	6.50	1.06	R-31	5.31	6.50	1.06	R-31	5.31	6.50	1.06
4" (DN 100)	R-36	6.19	6.50	1.06	R-37	6.31	6.50	1.06	R-37	6.31	6.50	1.06
6" (DN 150)	R-43	7.94	7.50	1.06	R-45	8.75	7.50	1.06	R-45	8.75	7.50	1.06
8" (DN 200)	R-48	10.06	7.50	1.06	R-49	11.06	7.50	1.06	R-49	11.06	7.50	1.06
10" (DN 250)	R-52	12.31	8.50	1.06	R-53	13.19	8.50	1.06	R-53	13.19	8.50	1.06
12" (DN 300)	R-56	15.31	8.50	1.06	R-57	15.44	8.50	1.06	R-57	15.44	8.50	1.06
14" (DN 350)	R-59	15.94	8.50	1.06	R-61	16.94	8.50	1.06	R-61	16.94	8.50	1.06
16" (DN 400)	R-64	18.06	8.50	1.19	R-65	18.94	8.50	1.19	R-65	18.94	8.50	1.19
18" (DN 450)	R-68	20.69	8.50	1.19	R-69	21.44	8.50	1.19	R-69	21.44	8.50	1.19
20" (DN 500)	R-72	22.31	8.50	1.25	R-73	23.50	8.50	1.25	R-73	23.50	8.50	1.25
24" (DN 600)	R-76	26.81	8.50	1.44	R-77	27.88	8.50	1.44	R-77	27.88	8.50	1.44
LINE SIZE	FLANGE RATING											
	900#				1500#				2500#			
	Ring No.	C	D	E	Ring No.	C	D	E	Ring No.	C	D	E
2" (DN 50)	R-24	4.19	6.50	1.06	R-24	4.19	6.50	1.06	R-26	4.44	6.50	1.06
2-1/2" (DN 65)	R-27	4.69	6.50	1.06	R-27	4.69	6.50	1.06	R-28	4.83	6.50	1.19
3" (DN 80)	R-31	5.31	6.50	1.06	R-35	5.81	6.50	1.06	R-32	5.50	7.50	1.19
4" (DN 100)	R-37	6.31	6.50	1.06	R-39	6.81	6.50	1.06	R-38	6.81	7.50	1.31
6" (DN 150)	R-45	8.75	7.50	1.06	R-46	8.81	7.50	1.19	R-47	9.75	8.50	1.44
8" (DN 200)	R-49	11.06	7.50	1.06	R-50	11.25	7.50	1.44	R-51	11.88	9.50	1.69
10" (DN 250)	R-53	13.19	8.50	1.06	R-54	13.38	8.50	1.44	R-55	14.63	9.50	2.00
12" (DN 300)	R-57	15.44	8.50	1.06	R-58	15.88	9.50	1.69	R-60	17.25	10.50	2.13
14" (DN 350)	R-62	17.13	8.50	1.31	R-63	17.50	9.50	1.88				
16" (DN 400)	R-66	19.13	8.50	1.44	R-67	19.63	10.50	2.13				
18" (DN 450)	R-70	21.75	8.50	1.56	R-71	22.13	10.50	2.13				
20" (DN 500)	R-74	23.75	8.50	1.56	R-75	24.25	11.50	2.13				
24" (DN 600)	R-78	28.25	10.50	1.88	R-79	28.63	11.50	2.44				

<b>ROSEMOUNT®</b>		
BOULDER, COLORADO		
SIZE A	FSCM.NO.	DRAWING NO. <b>01495-1003</b>
SCALE: 1:2	WT.	SHEET: 2 of 14

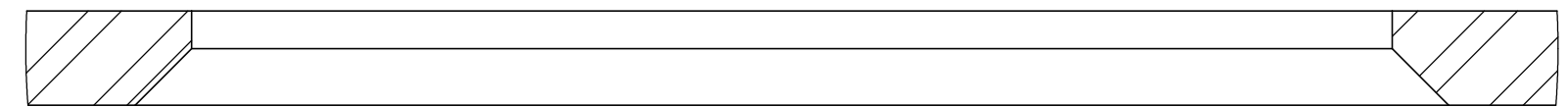
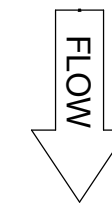
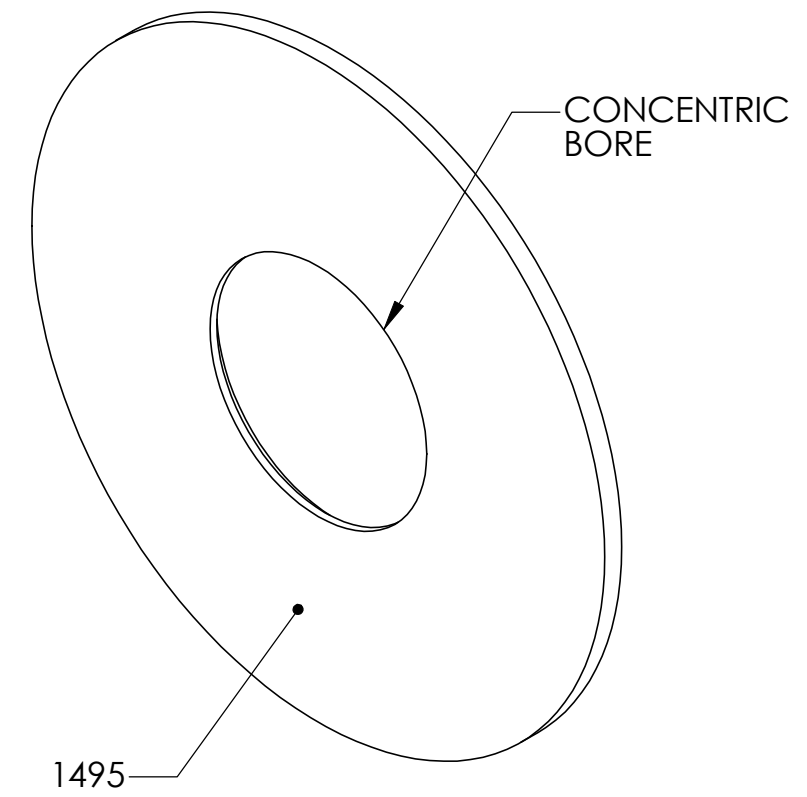
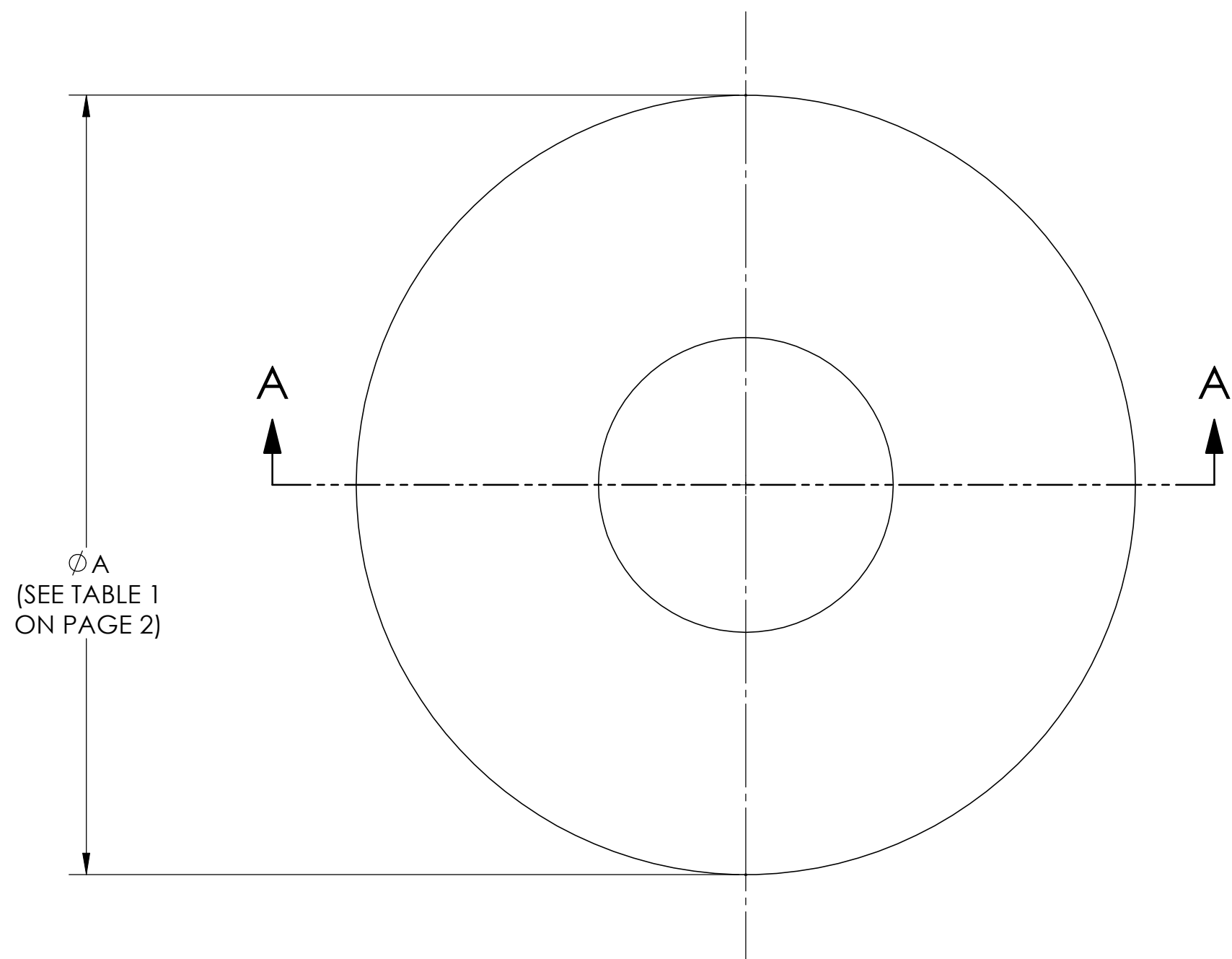

DETAIL B  
SCALE 2 : 1

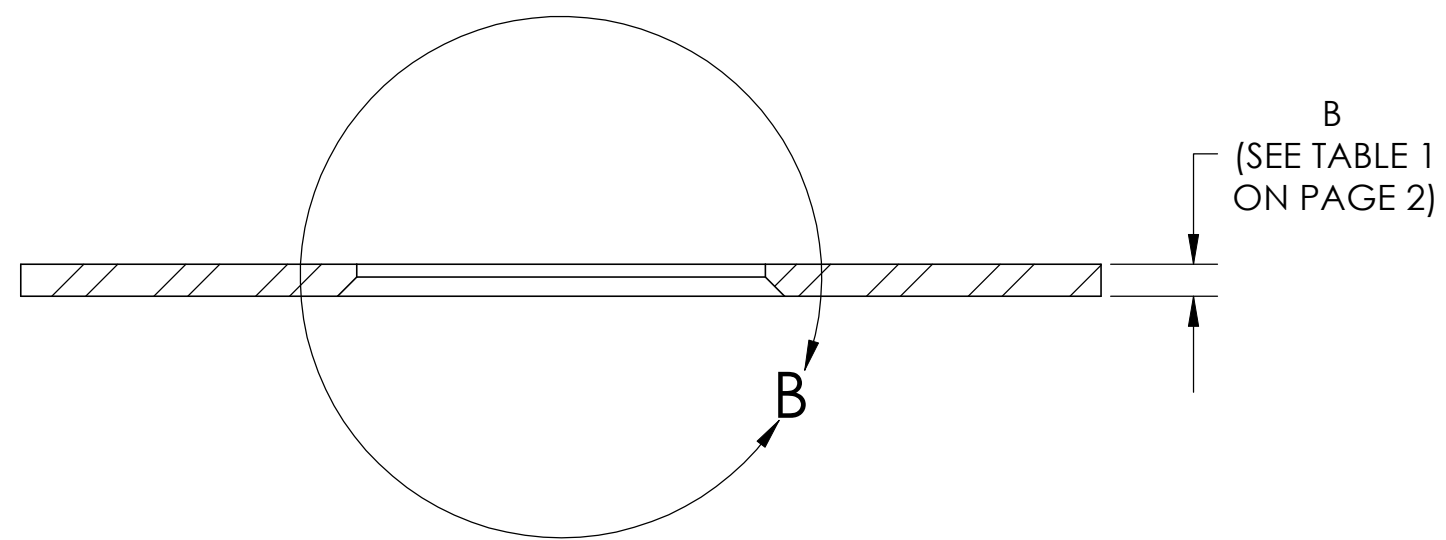

SECTION A-A

**CONCENTRIC BORE**

<b>ROSEMOUNT®</b>			
BOULDER, COLORADO			
SIZE A	FSCM.NO.	DRAWING NO. 01495-1003	
SCALE: 1:1.5	WT.	SHEET: 3 of 14	

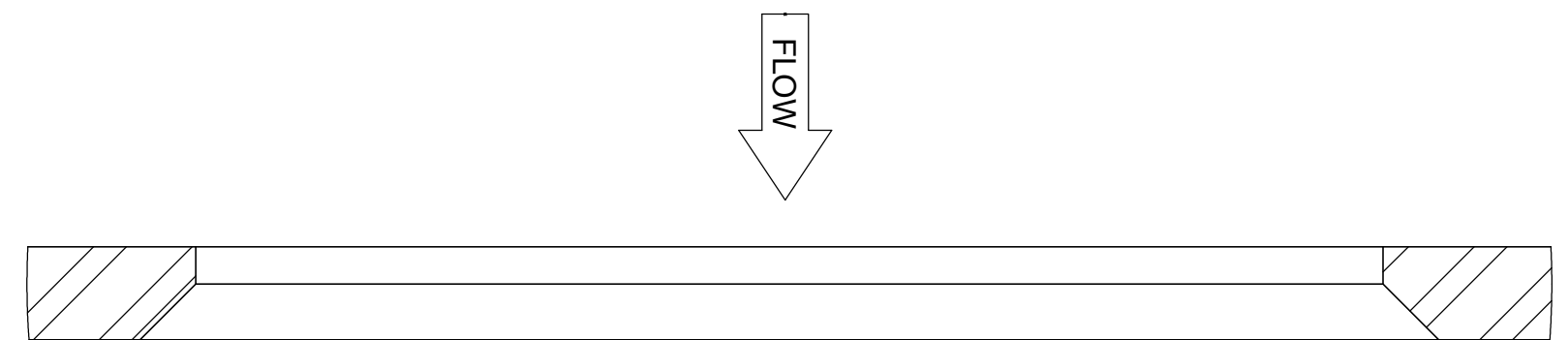
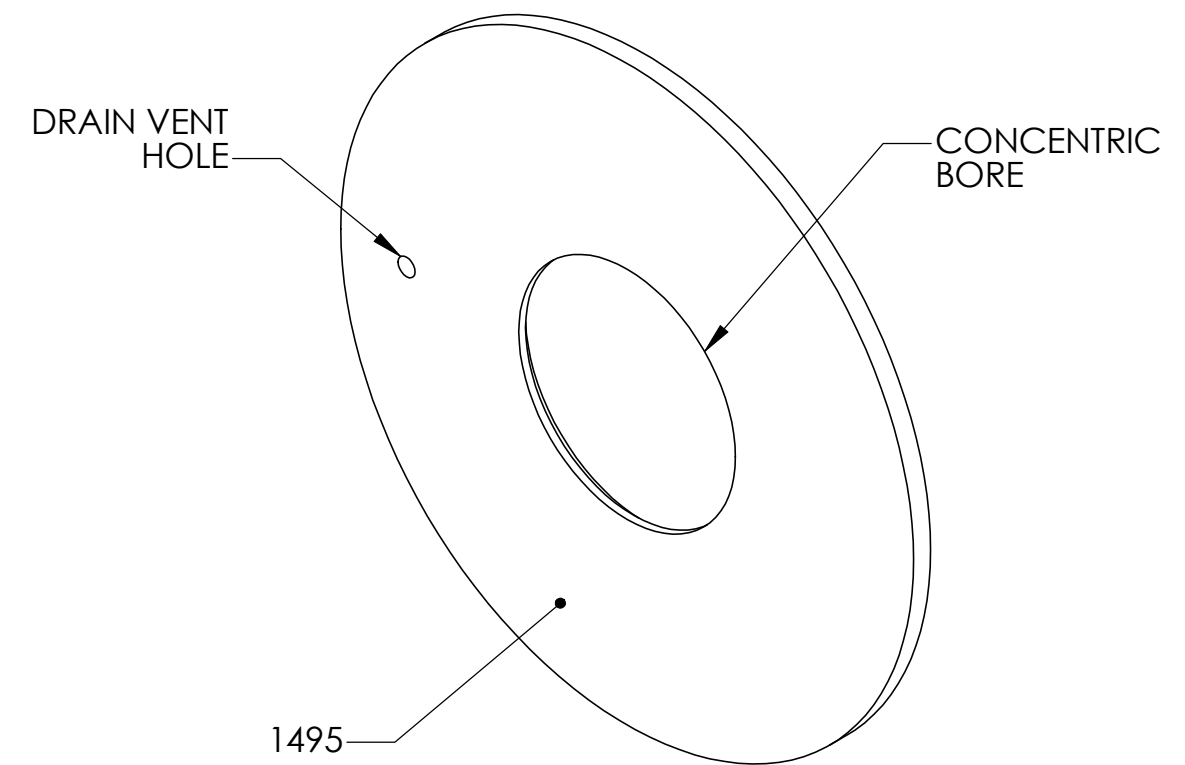
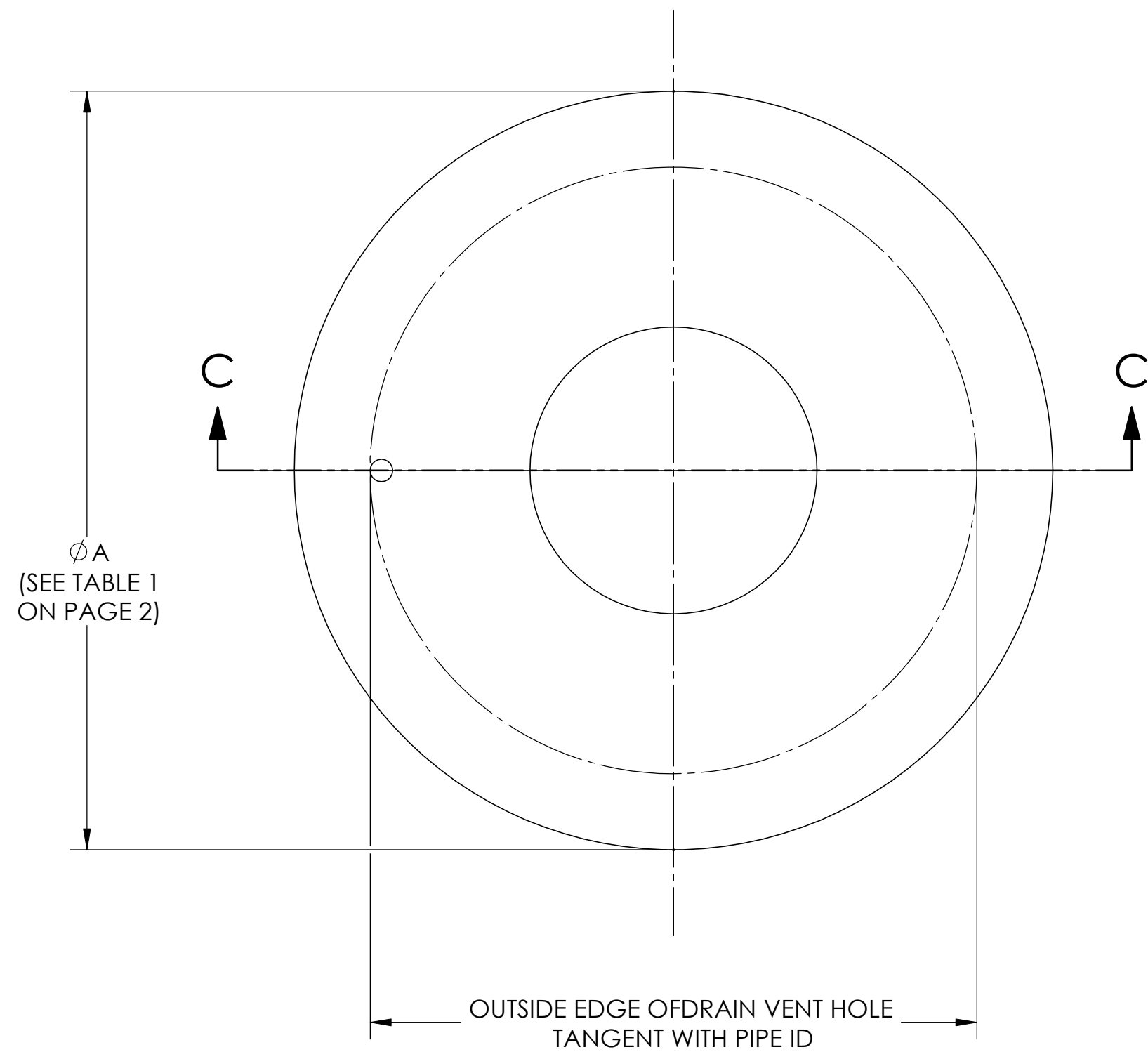

DETAIL D  
SCALE 2 : 1

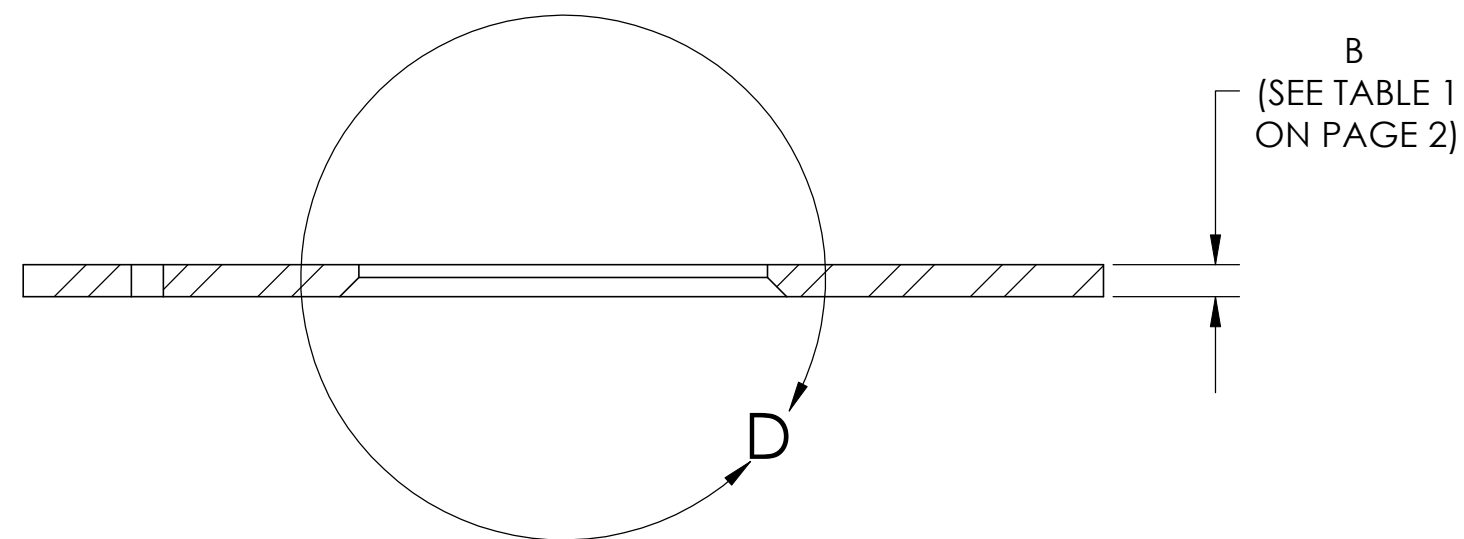

SECTION C-C

**CONCENTRIC BORE  
WITH DRAIN/VENT HOLE**

<b>ROSEMOUNT®</b>			
BOULDER, COLORADO			
SIZE A	FSCM.NO.	DRAWING NO. 01495-1003	
SCALE: 1:1.5	WT.	SHEET: 4 of 14	

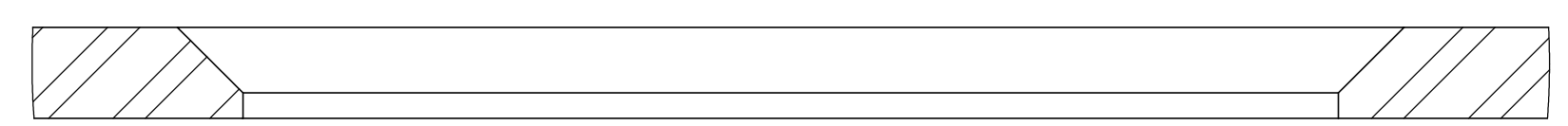
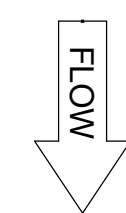
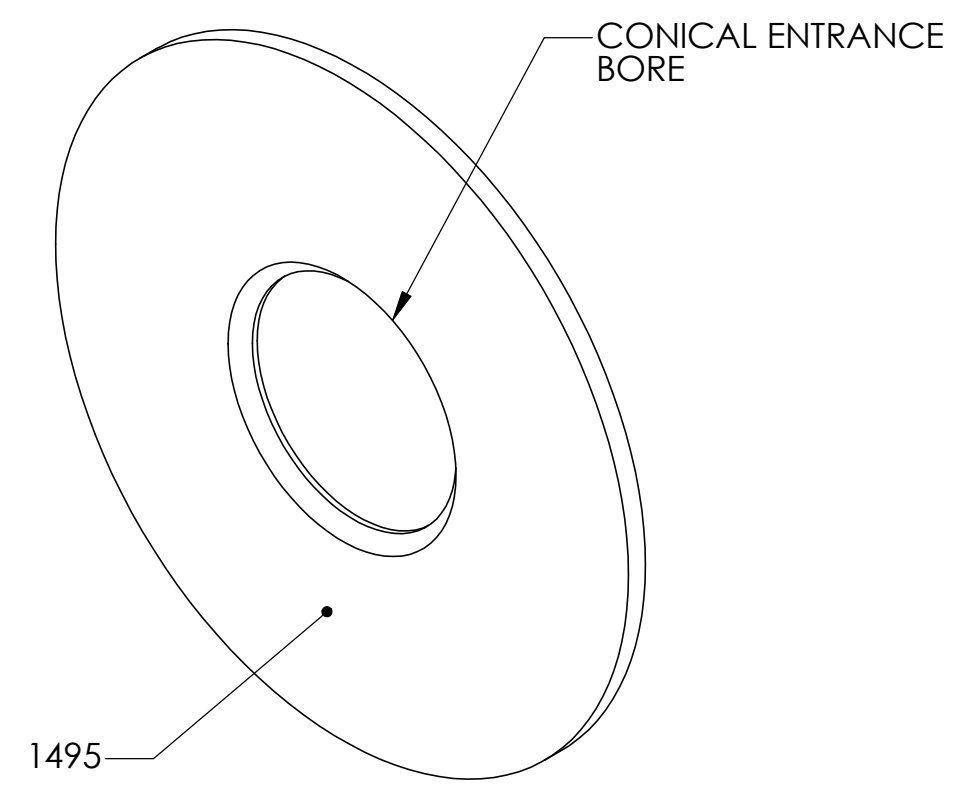
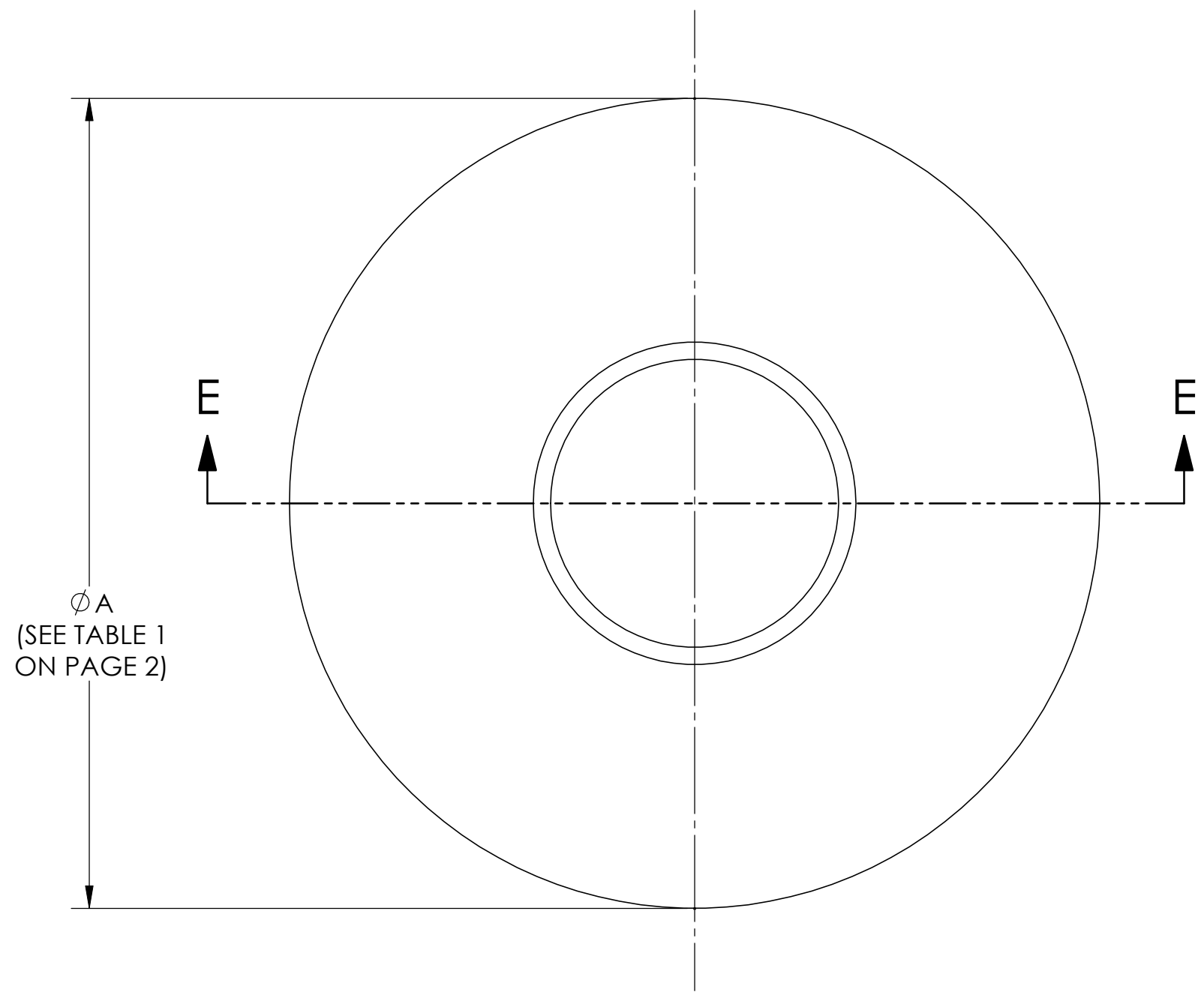

DETAIL F  
SCALE 2 : 1

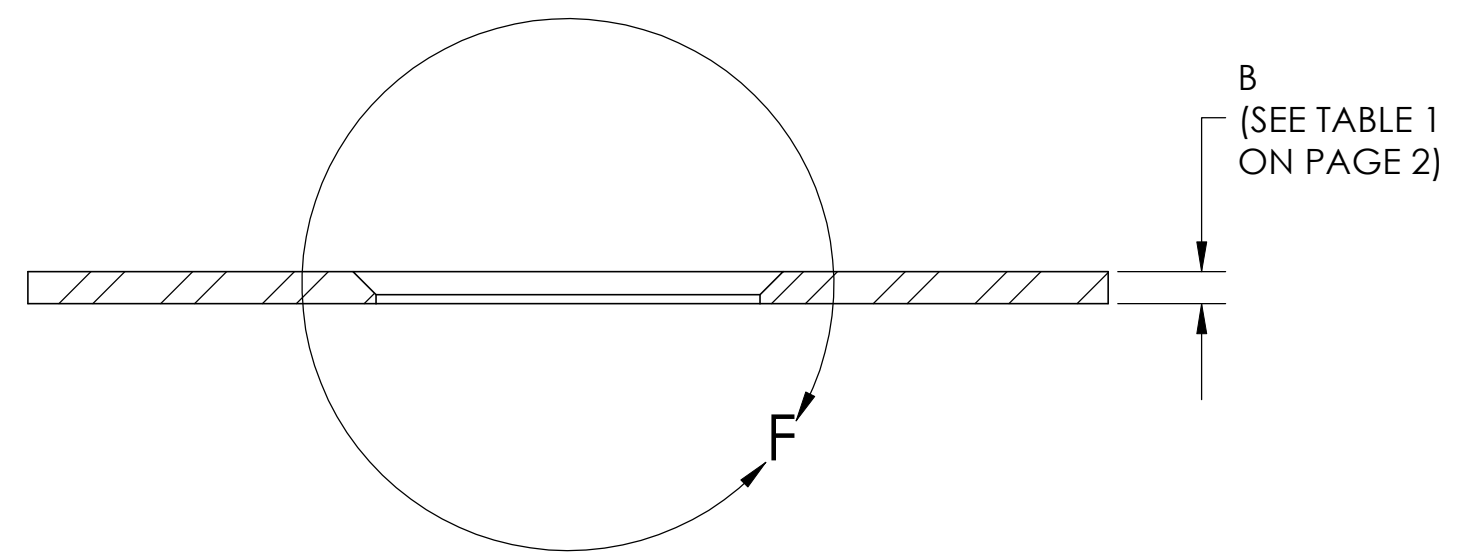

SECTION E-E

**CONICAL ENTRANCE BORE**

<b>ROSEMOUNT®</b>			
BOULDER, COLORADO			
SIZE A	FSCM.NO.	DRAWING NO. 01495-1003	
SCALE: 1:1.5	WT.	SHEET: 5 of 14	

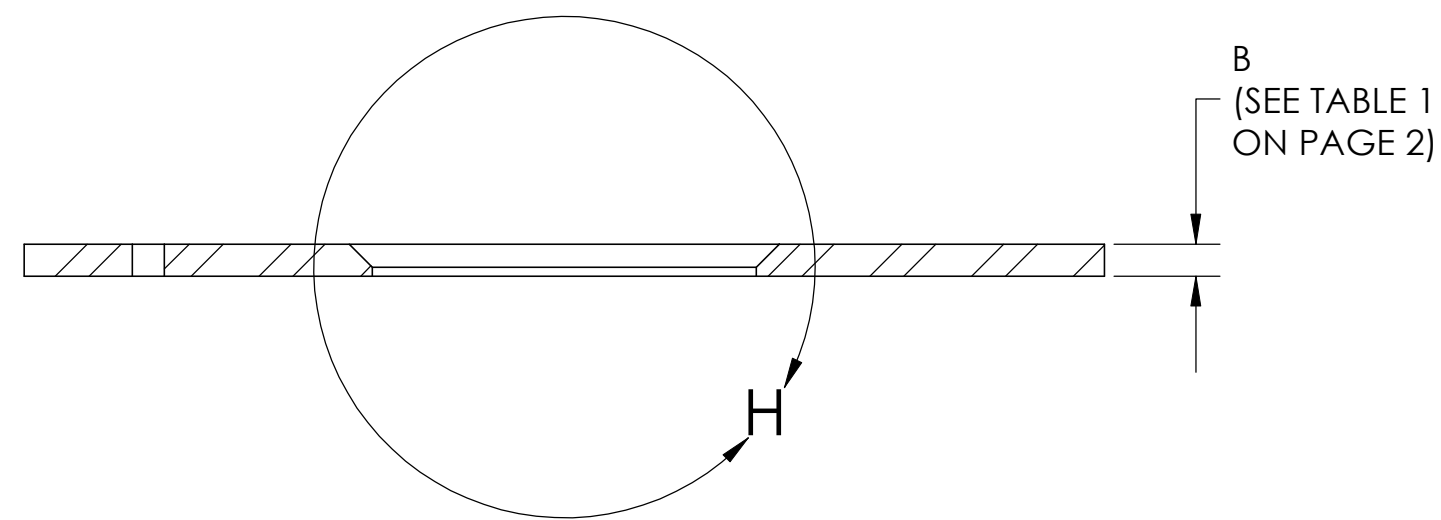
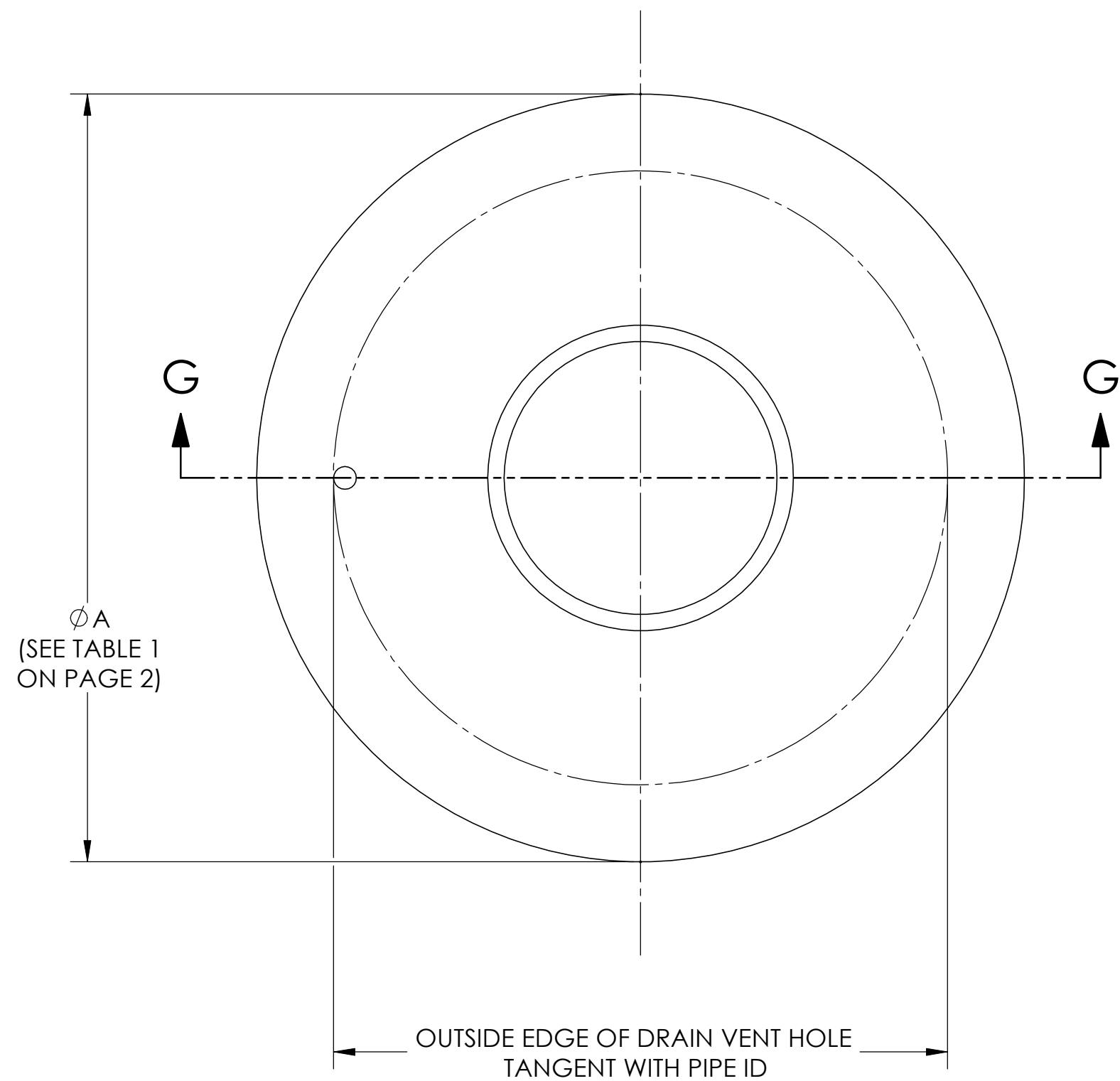

SECTION G-G

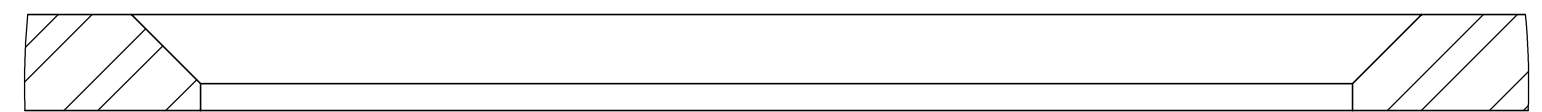
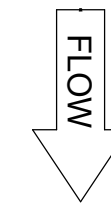
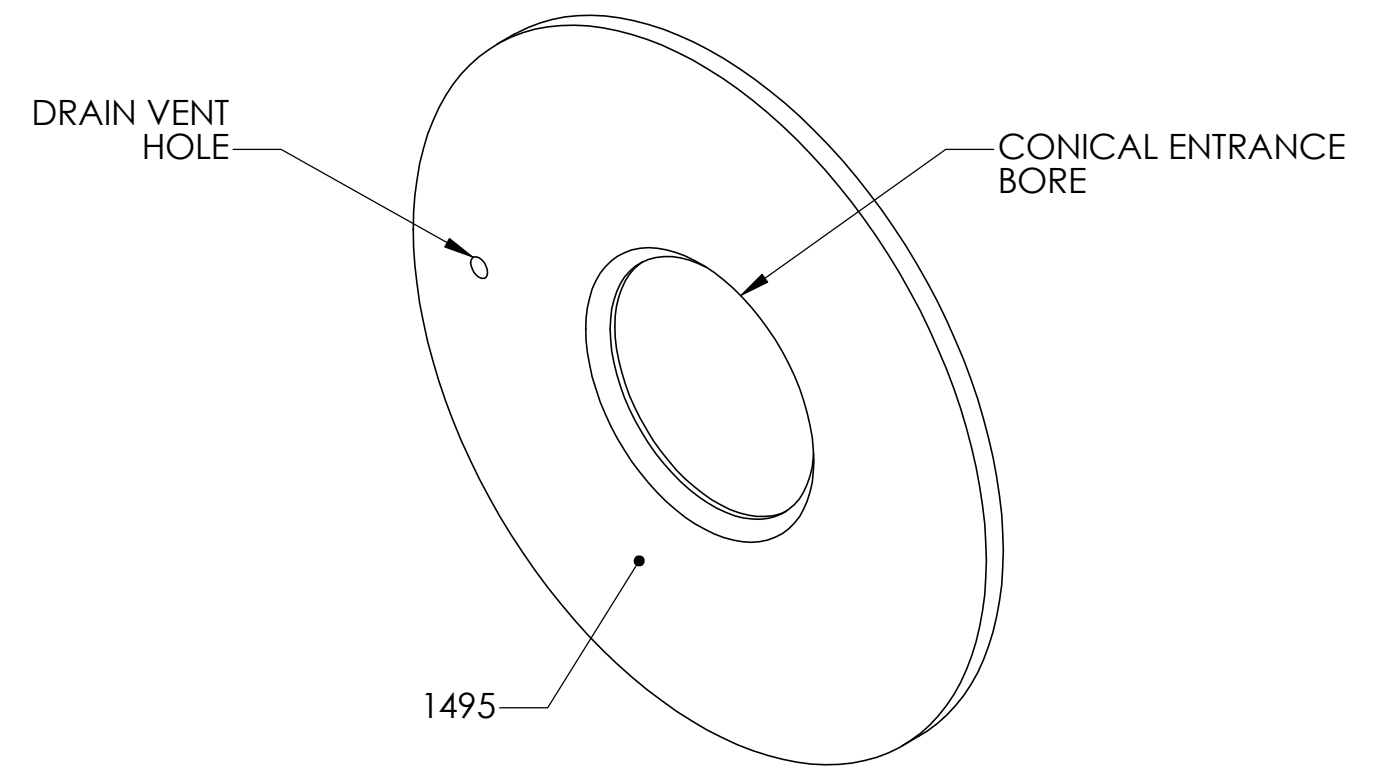

DETAIL H  
SCALE 2 : 1

**CONICAL ENTRANCE BORE  
WITH DRAIN/VENT HOLE**

<b>ROSEMOUNT®</b>			
BOULDER, COLORADO			
SIZE A	FSCM.NO.	DRAWING NO. <b>01495-1003</b>	
SCALE: 1:1.5	WT.	SHEET: 6 of 14	

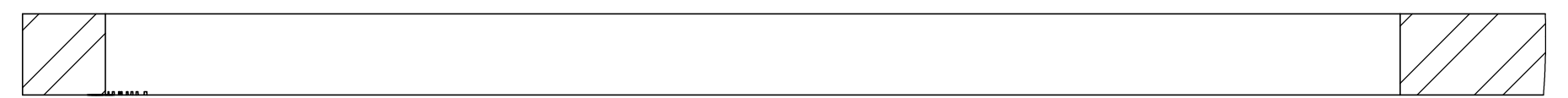
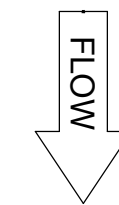
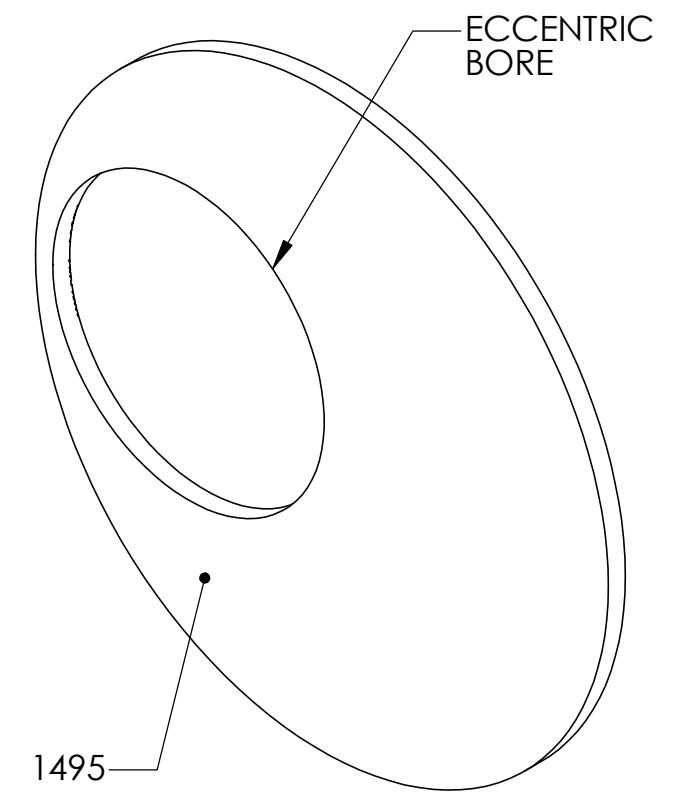
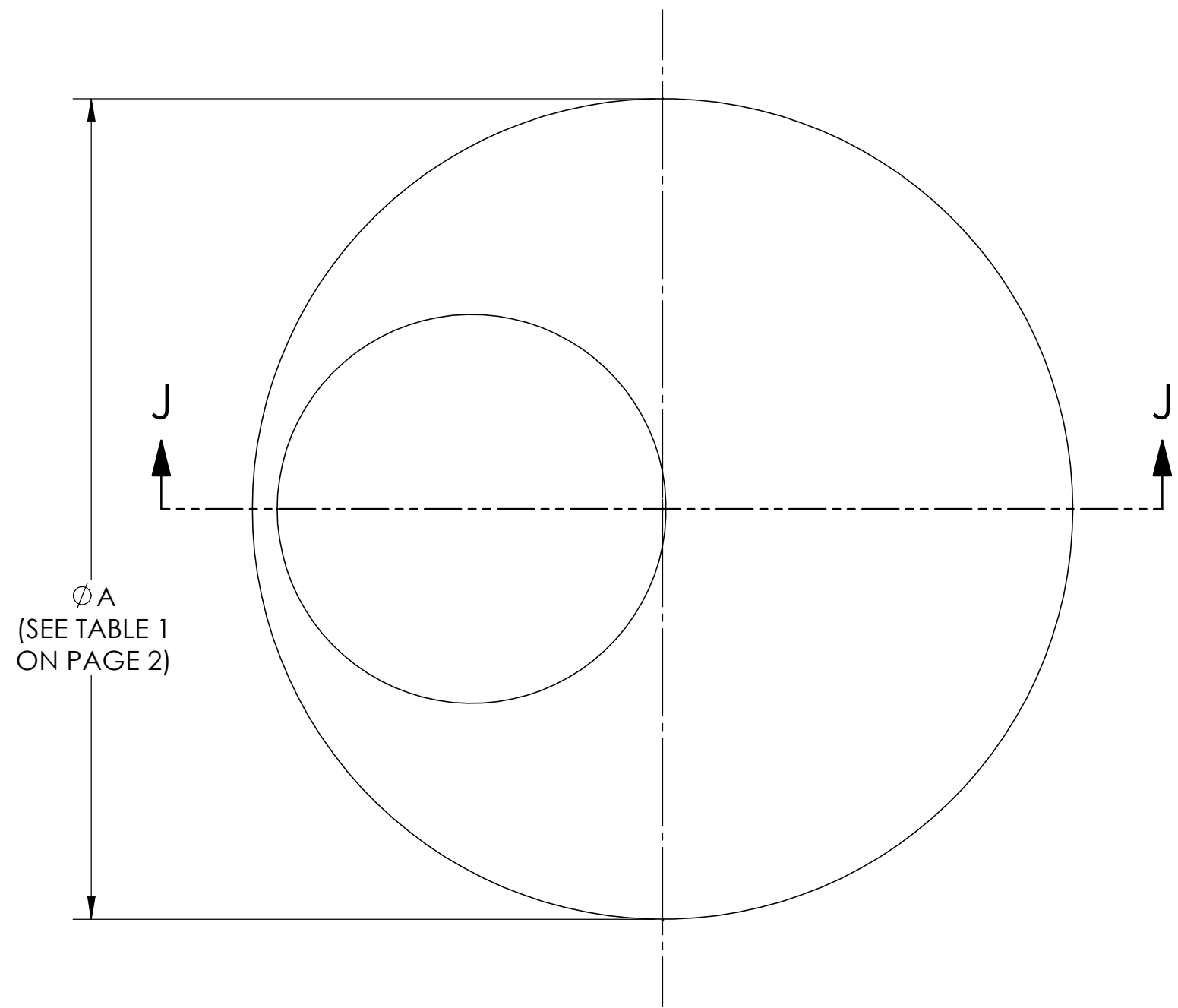

DETAIL K  
SCALE 2 : 1

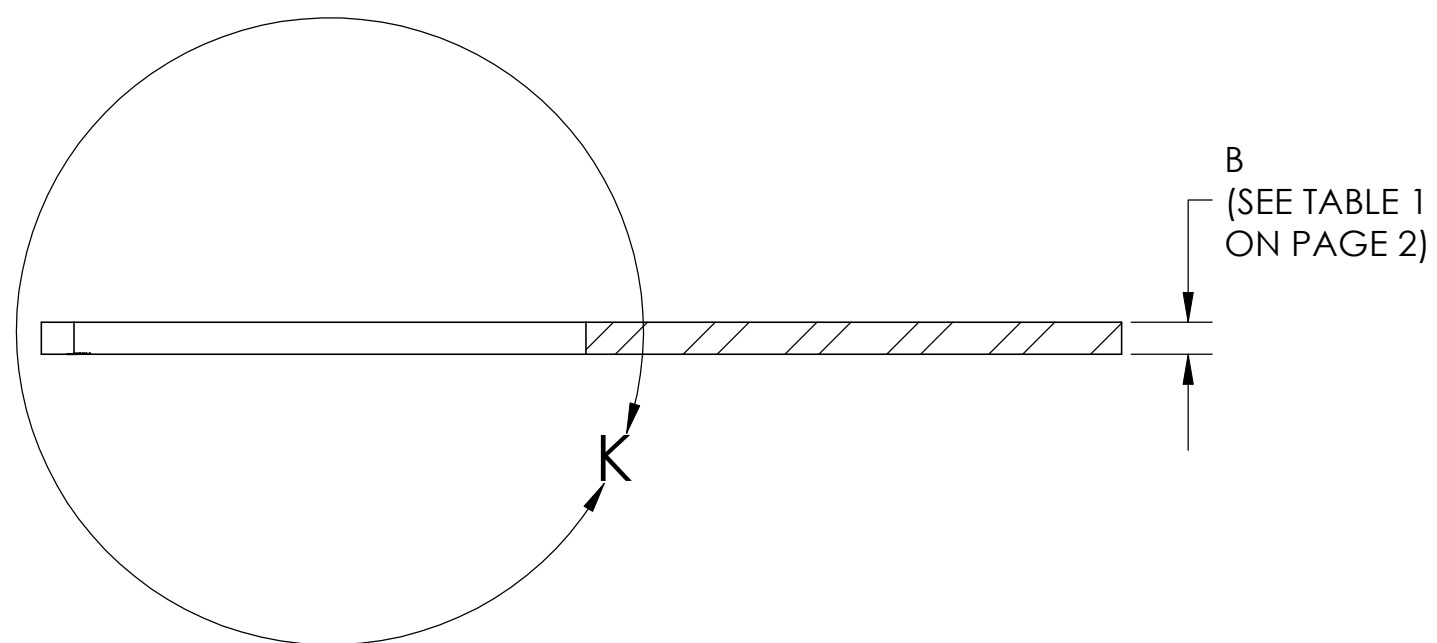

SECTION J-J

**ECCENTRIC BORE**

<b>ROSEMOUNT®</b>			
BOULDER, COLORADO			
SIZE A	FSCM.NO.	DRAWING NO. <b>01495-1003</b>	
SCALE: 1:1.5	WT.	SHEET: 7 of 14	

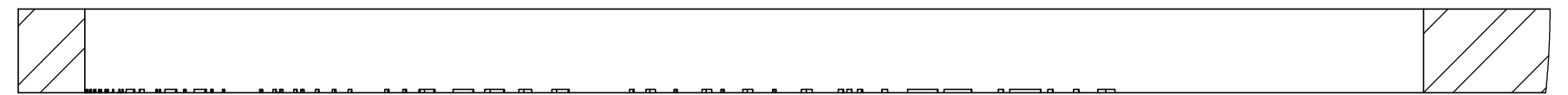
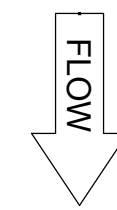
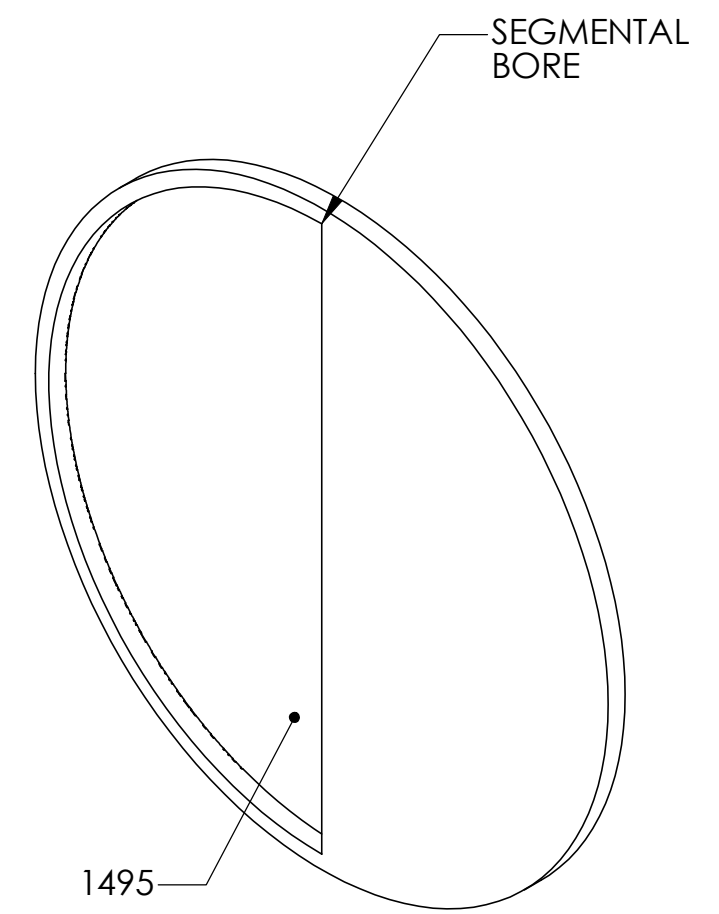
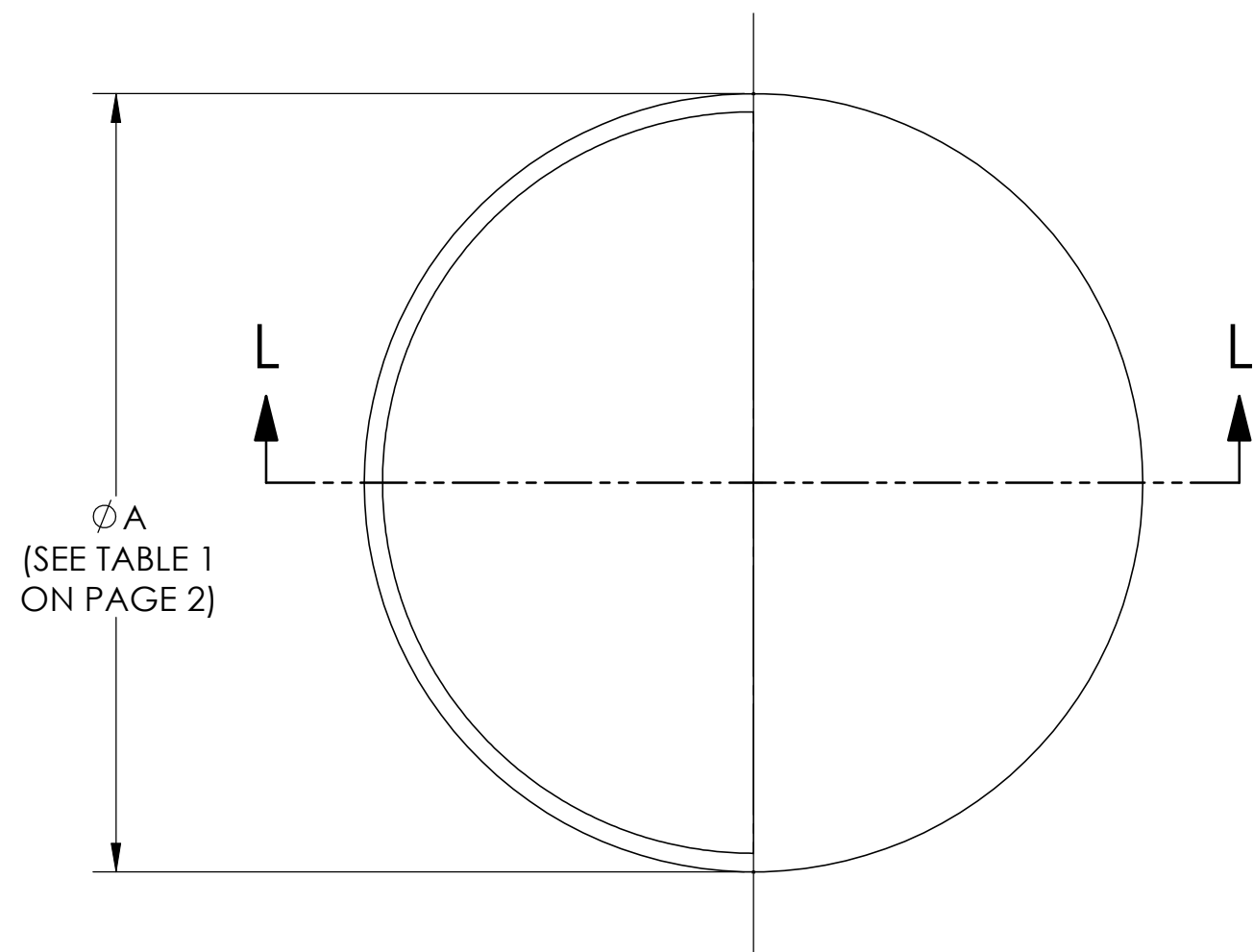

DETAIL M  
SCALE 2 : 1

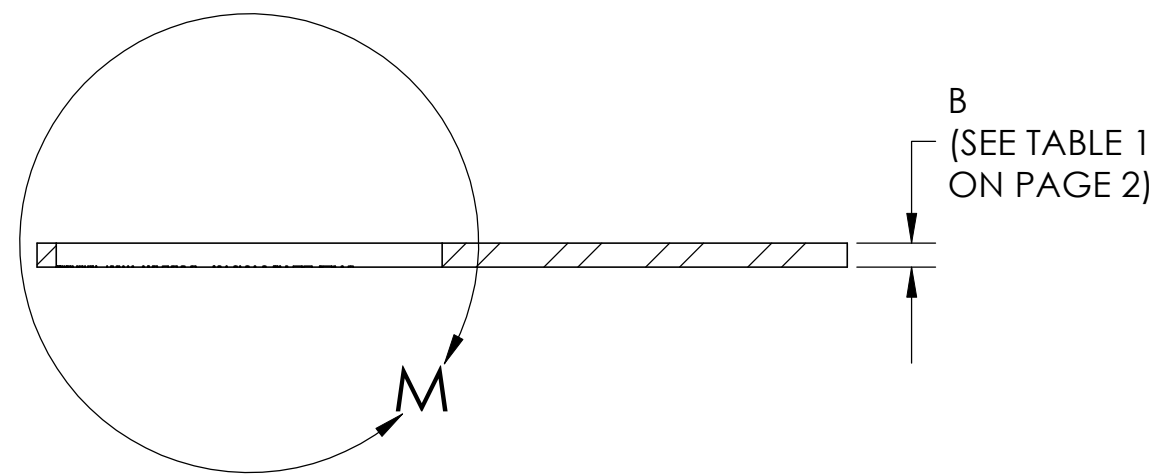

SECTION L-L

**SEGMENTAL BORE**

<b>ROSEMOUNT®</b>			
BOULDER, COLORADO			
SIZE A	FSCM.NO.	DRAWING NO. 01495-1003	
SCALE: 1:2	WT.	SHEET: 8 of 14	

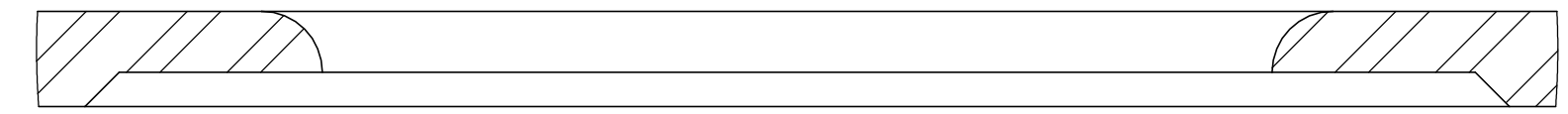
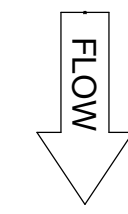
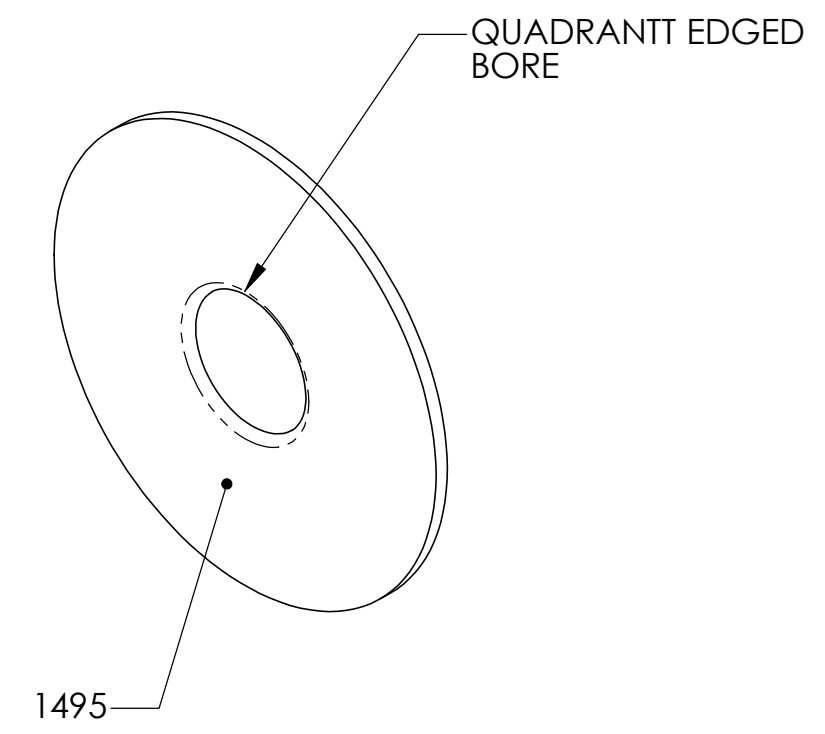
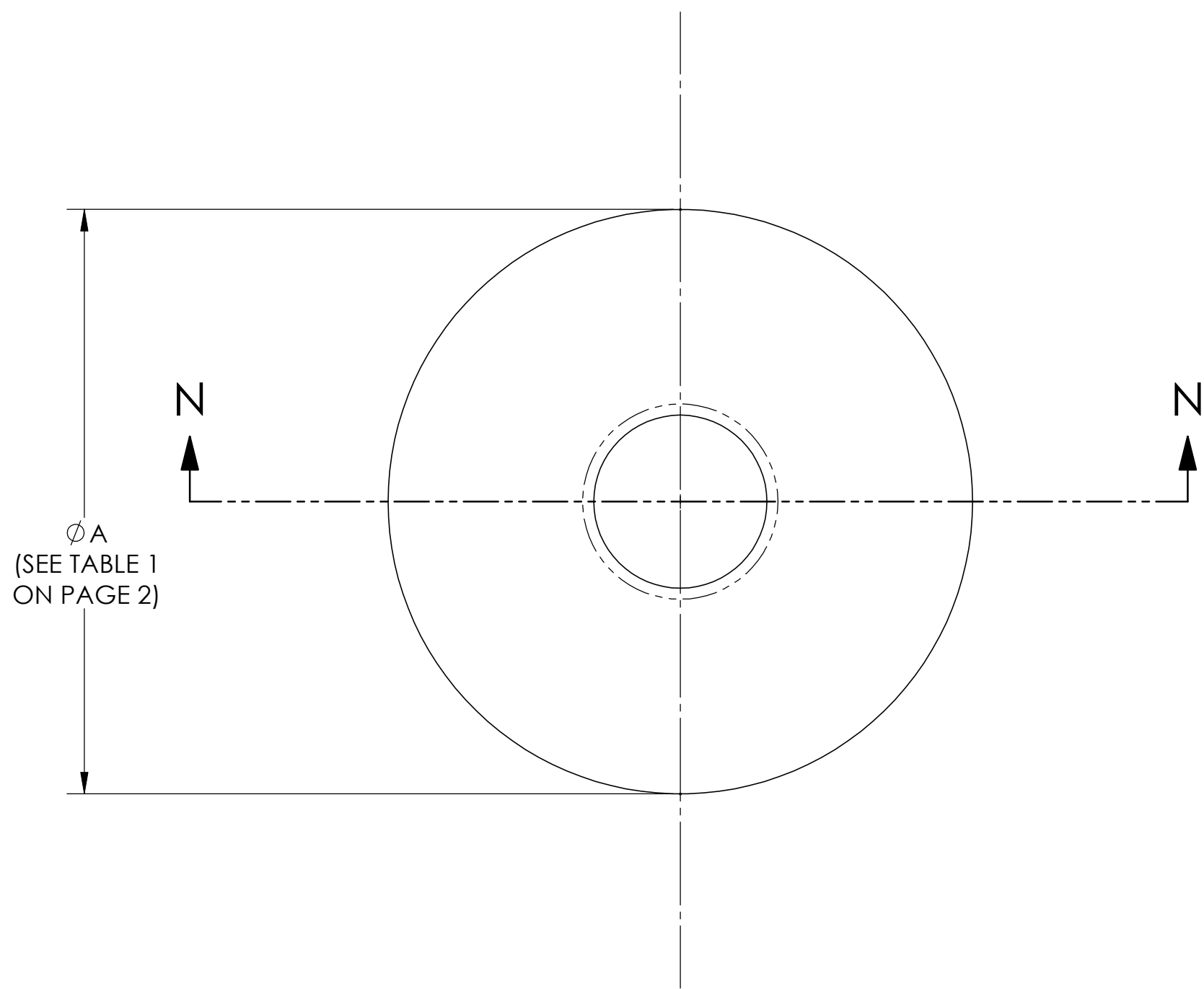

DETAIL P  
SCALE 2 : 1

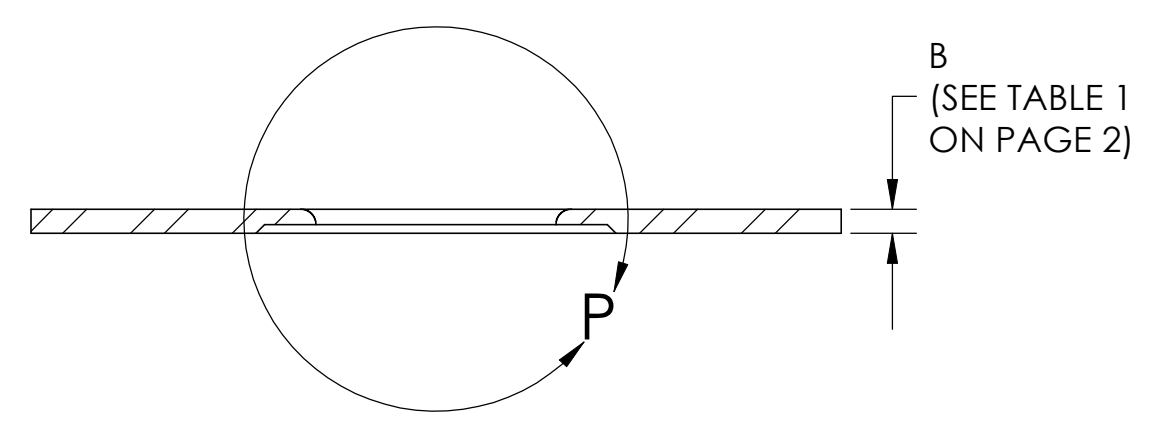

SECTION N-N

**QUADRANT EDGE BORE**

<b>ROSEMOUNT®</b>			
BOULDER, COLORADO			
SIZE A	FSCM.NO.	DRAWING NO. 01495-1003	
SCALE: 1:2	WT.	SHEET: 9 of 14	

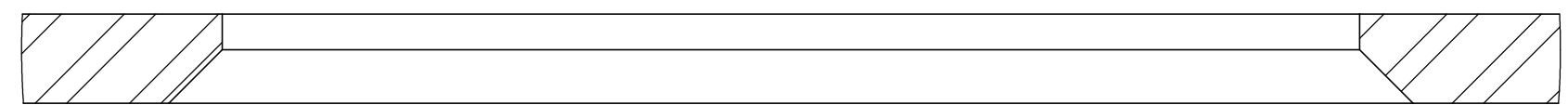
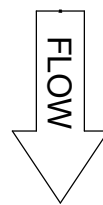
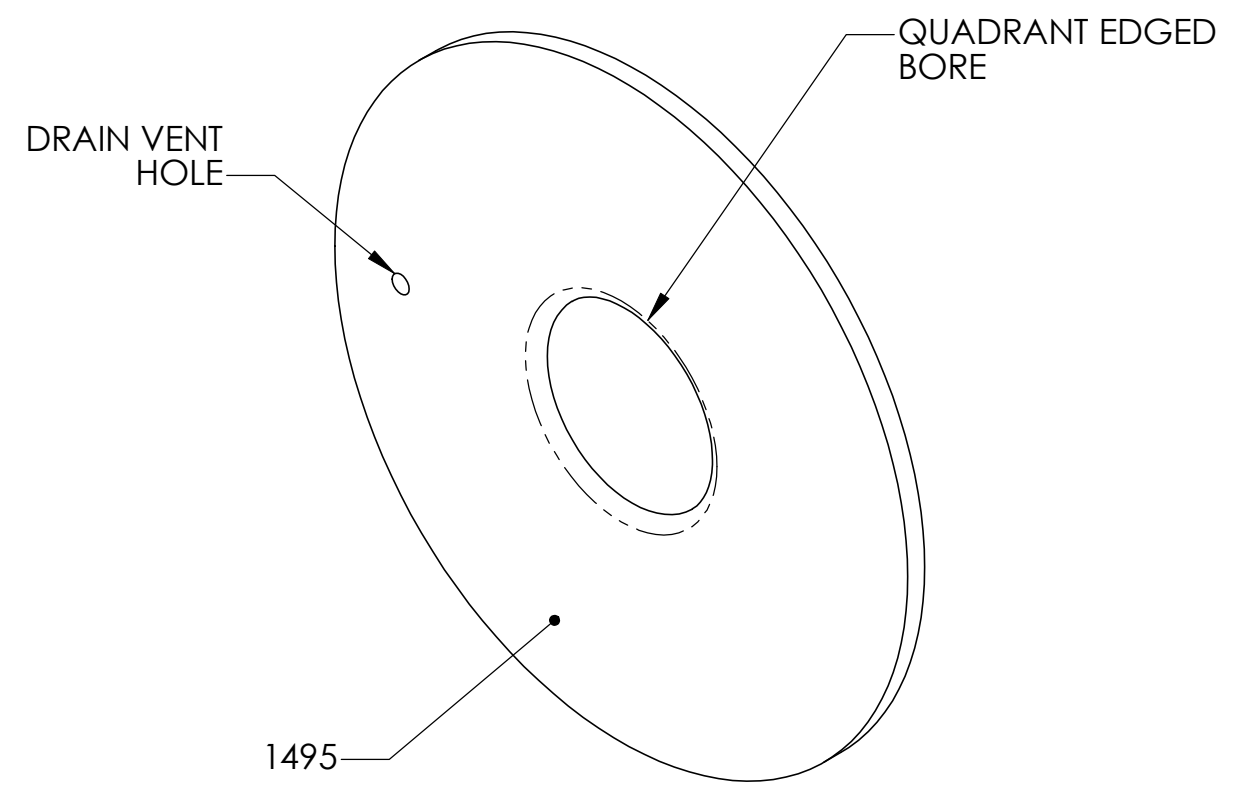
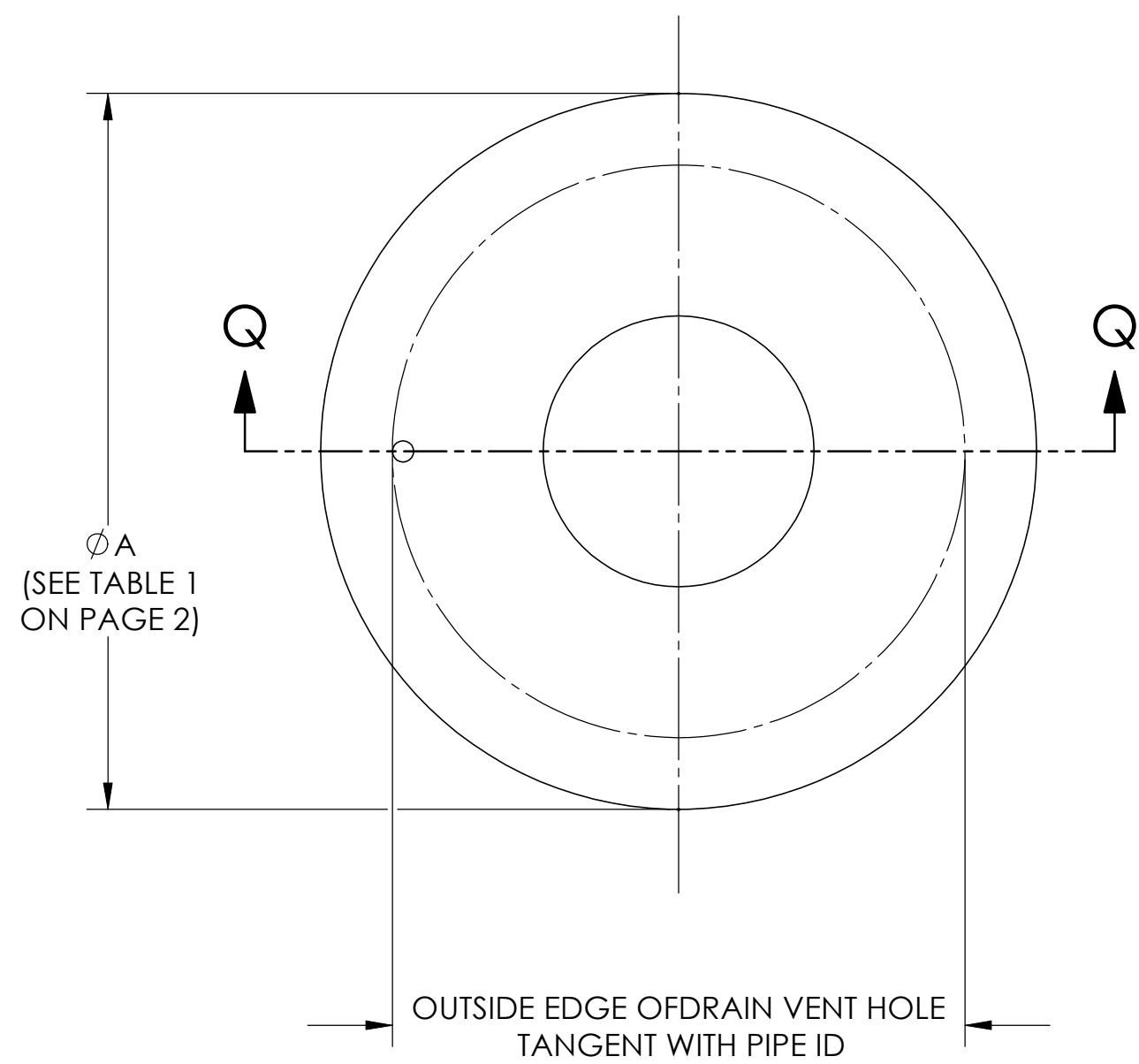

DETAIL R  
 SCALE 2 : 1

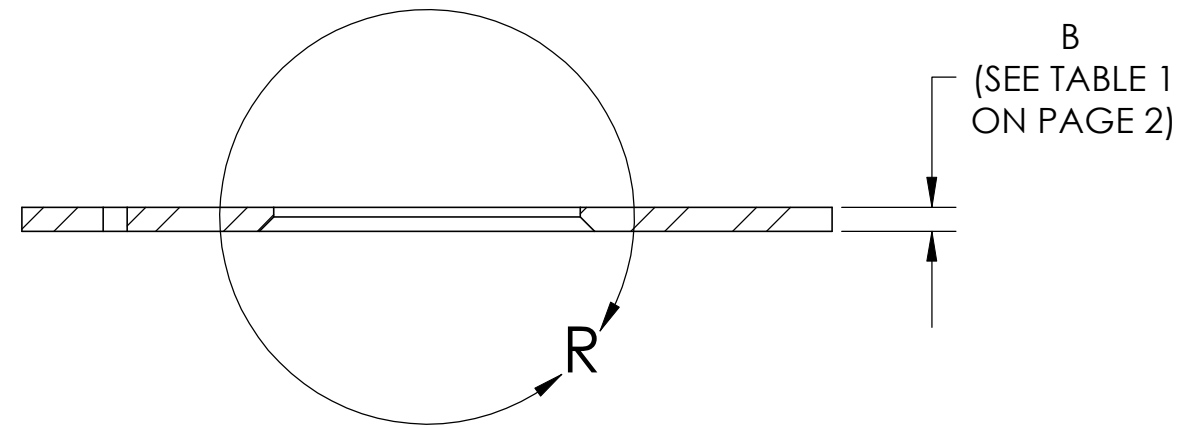

SECTION Q-Q

**QUADRANT EDGE BORE  
 WITH DRAIN/VENT HOLE**

<b>ROSEMOUNT®</b>			
BOULDER, COLORADO			
SIZE A	FSCM.NO.	DRAWING NO. 01495-1003	
SCALE: 1:2	WT.	SHEET: 10 of 14	

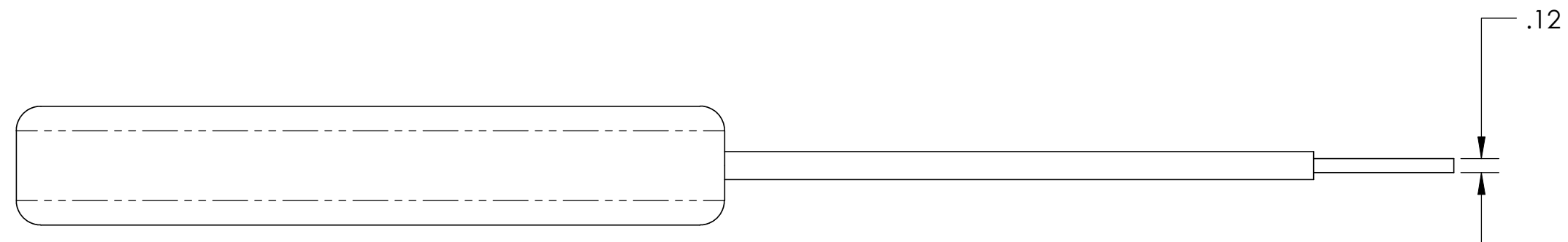

INTEGRAL  
UNIVERSAL  
PLATE HOLDER

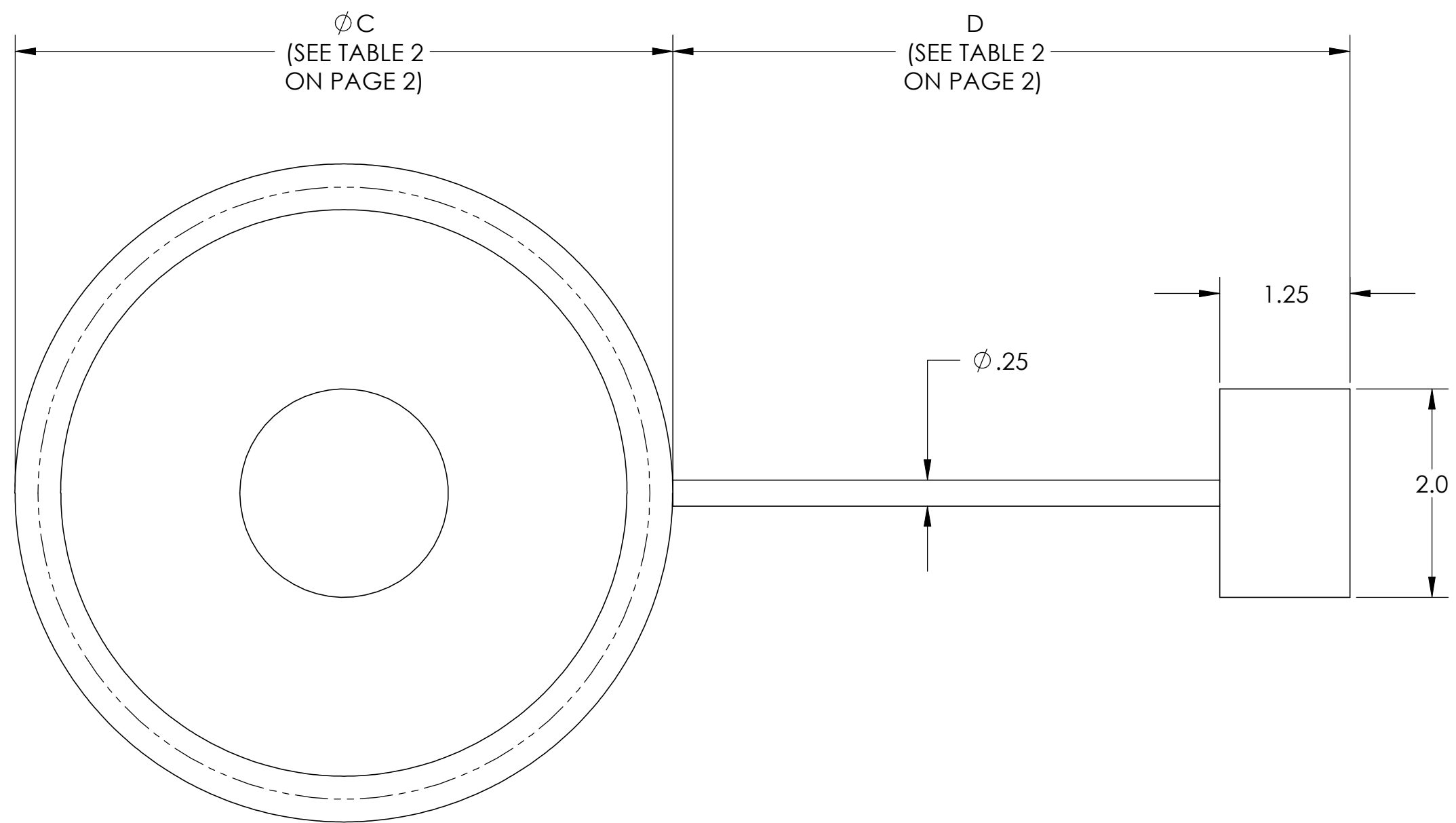
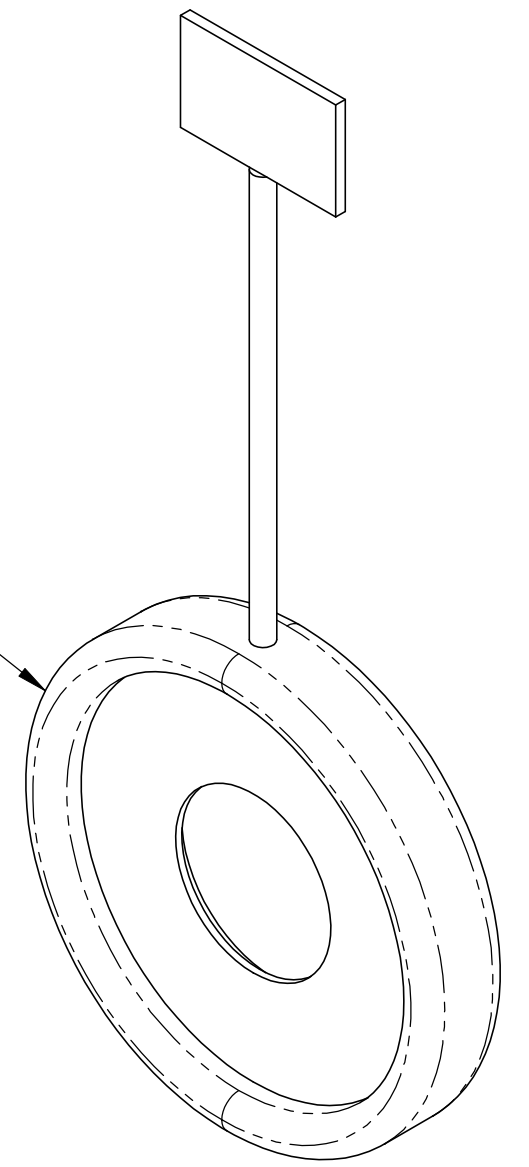

E  
(SEE TABLE 2  
ON PAGE 2)

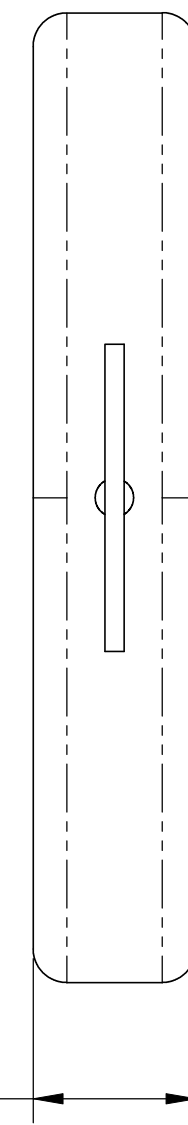

**INTEGRAL PLATE HOLDER**  
(STANDARD FOR SIZES 3" AND UNDER)

**ROSEMOUNT**<sup>®</sup>

BOULDER, COLORADO

SIZE A	FSCM.NO.	DRAWING NO. <b>01495-1003</b>
-----------	----------	----------------------------------

SCALE: 1:1.25	WT.	SHEET: 11 of 14
---------------	-----	-----------------

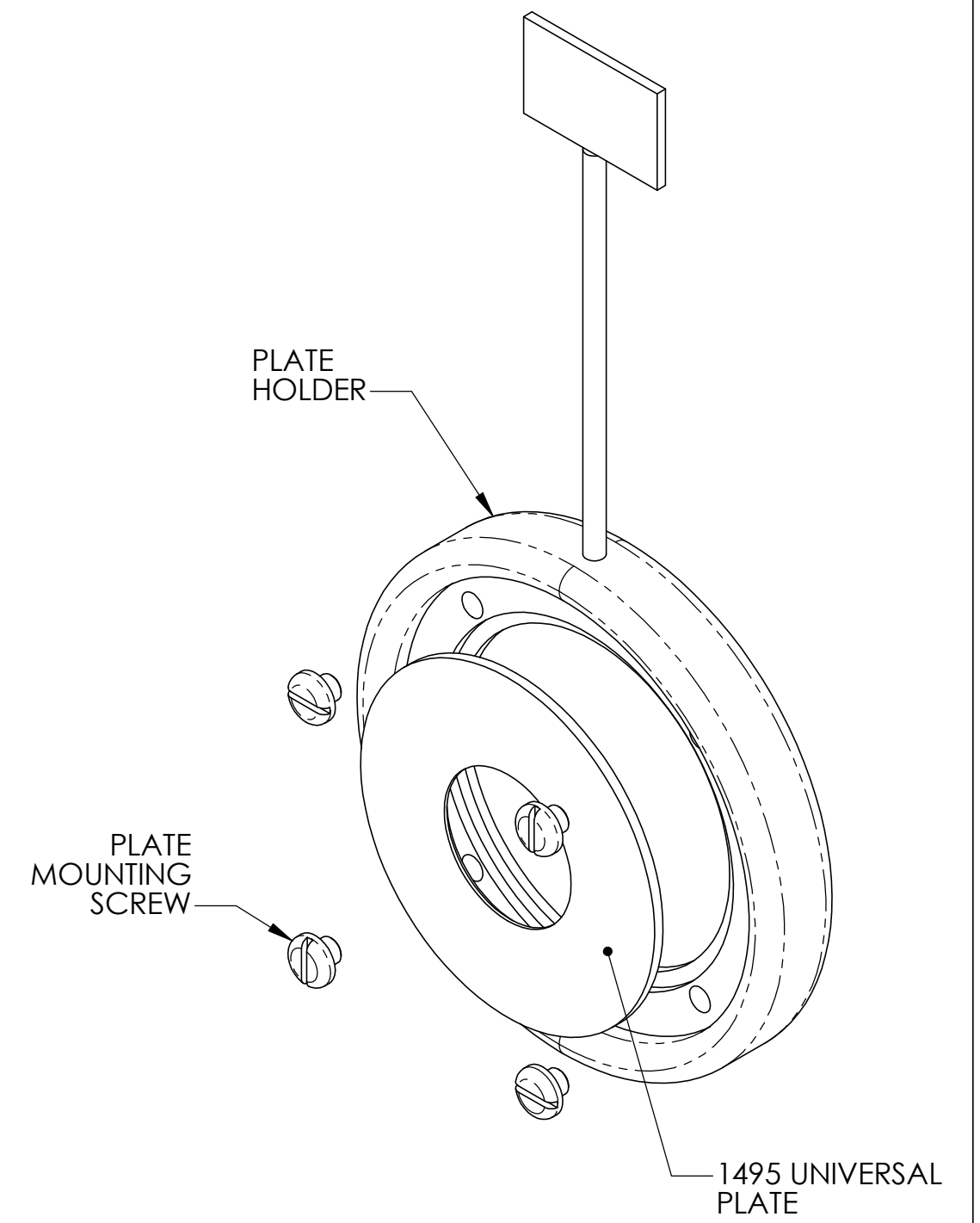
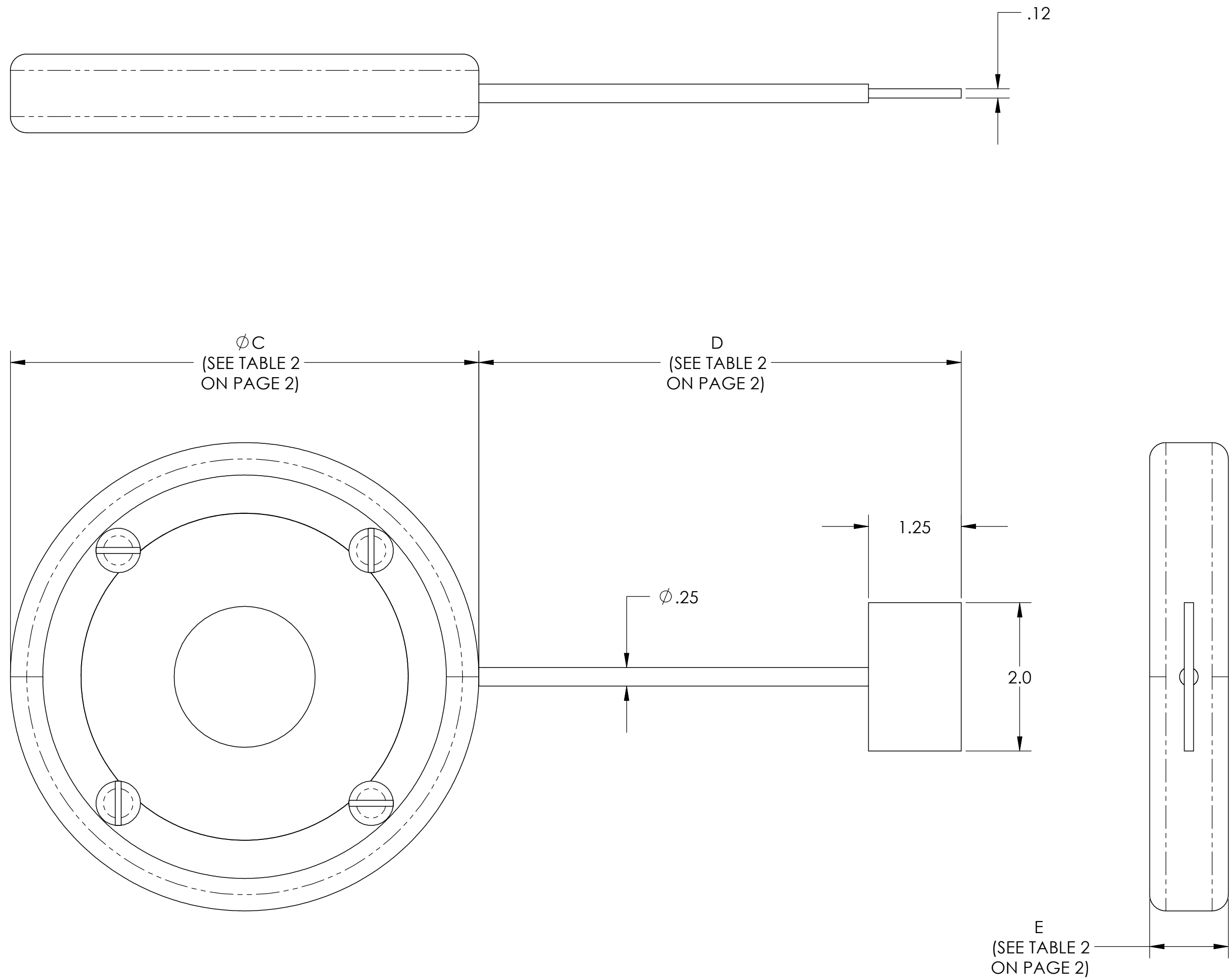

**SCREW-TYPE PLATE HOLDER**  
(STANDARD FOR SIZES 4" AND LARGER)

<b>ROSEMOUNT®</b>		
BOULDER, COLORADO		
SIZE A	FSCM.NO.	DRAWING NO. <b>01495-1003</b>
SCALE: 1:1.25	WT.	SHEET: 12 of 14

HORIZONTAL / VERTICAL GAS, LIQUID AND STEAM  
(RECOMMENDED INSTALLATION)

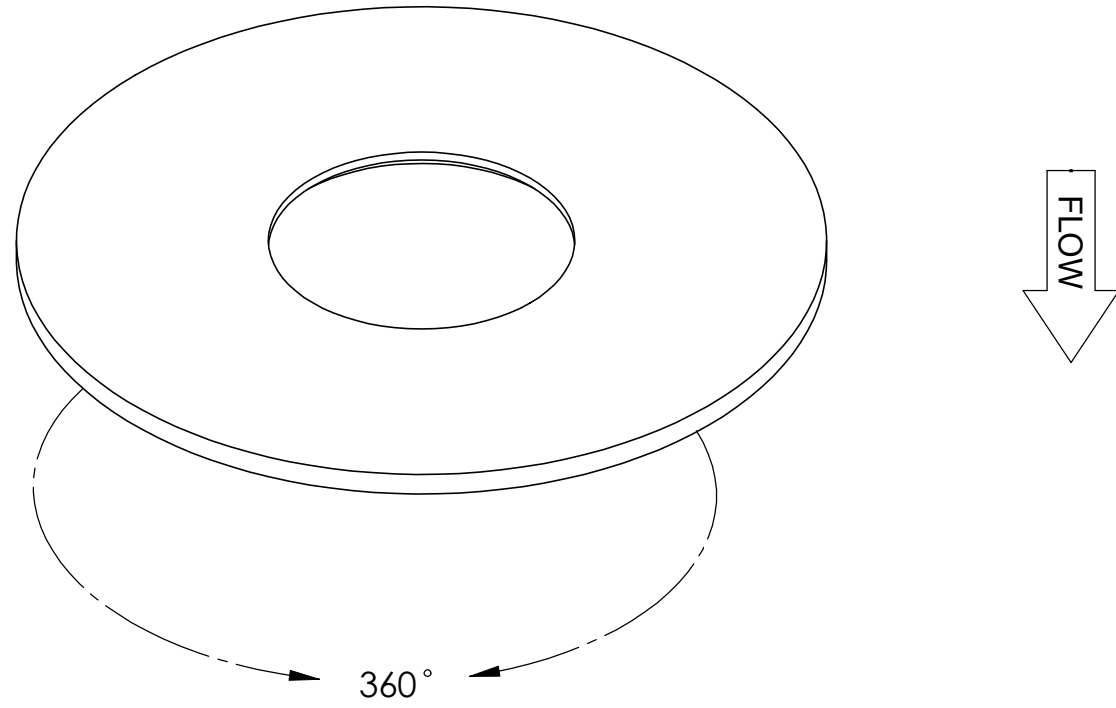

VERTICAL WITH DRAIN VENT HOLE  
GAS, LIQUID AND STEAM  
(RECOMMENDED INSTALLATION)

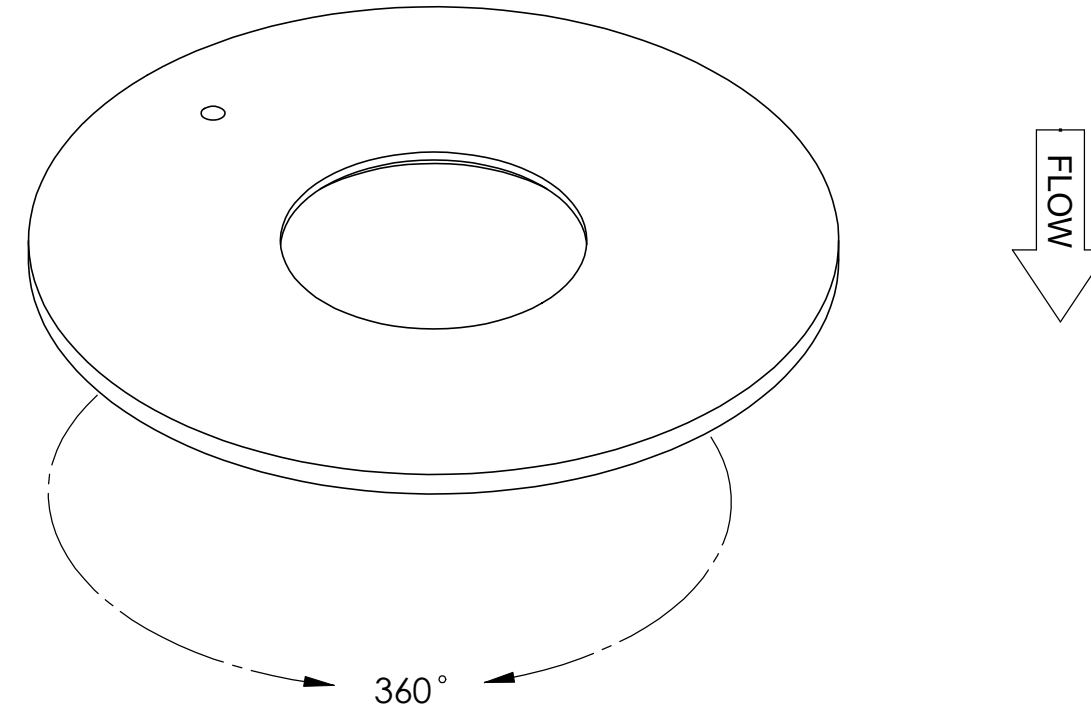

HORIZONTAL WITH DRAIN VENT HOLE  
GAS AND STEAM  
(RECOMMENDED INSTALLATION)

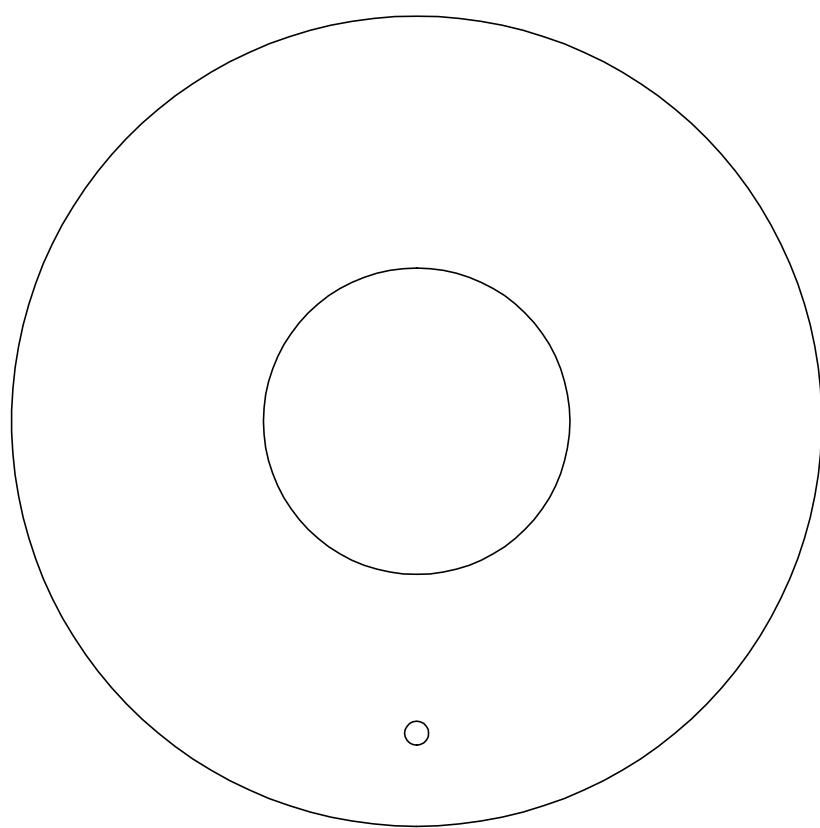

HORIZONTAL WITH DRAIN VENT HOLE  
LIQUID  
(RECOMMENDED INSTALLATION)

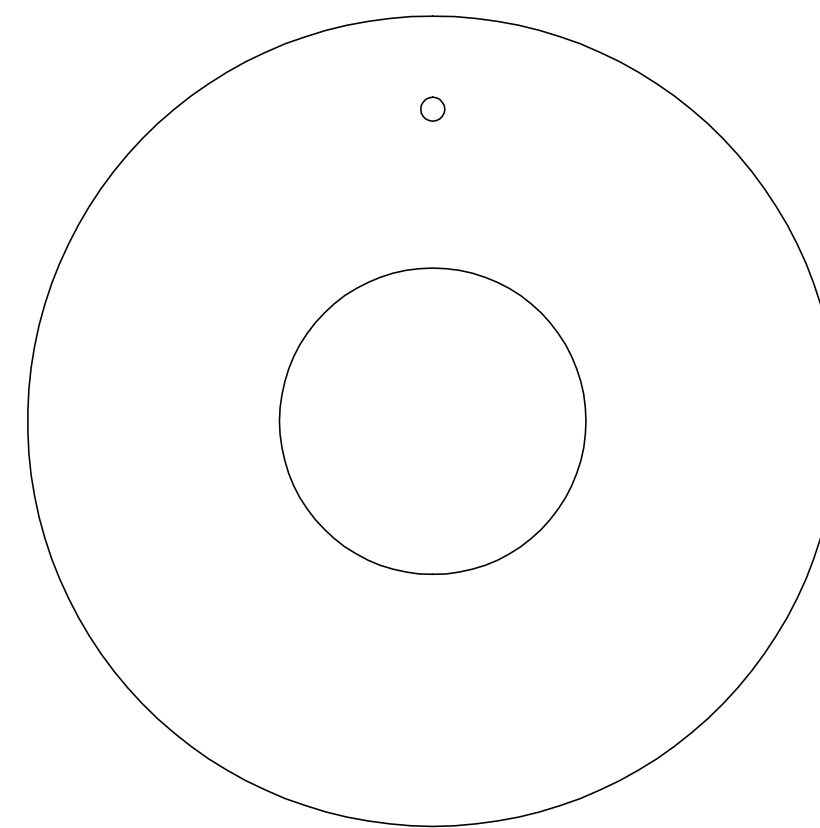

**ORIENTATION VIEW**

<b>ROSEMOUNT®</b>			
BOULDER, COLORADO			
SIZE A	FSCM.NO.	DRAWING NO.	01495-1003
SCALE: 1:2.5	WT.	SHEET: 13 of 14	

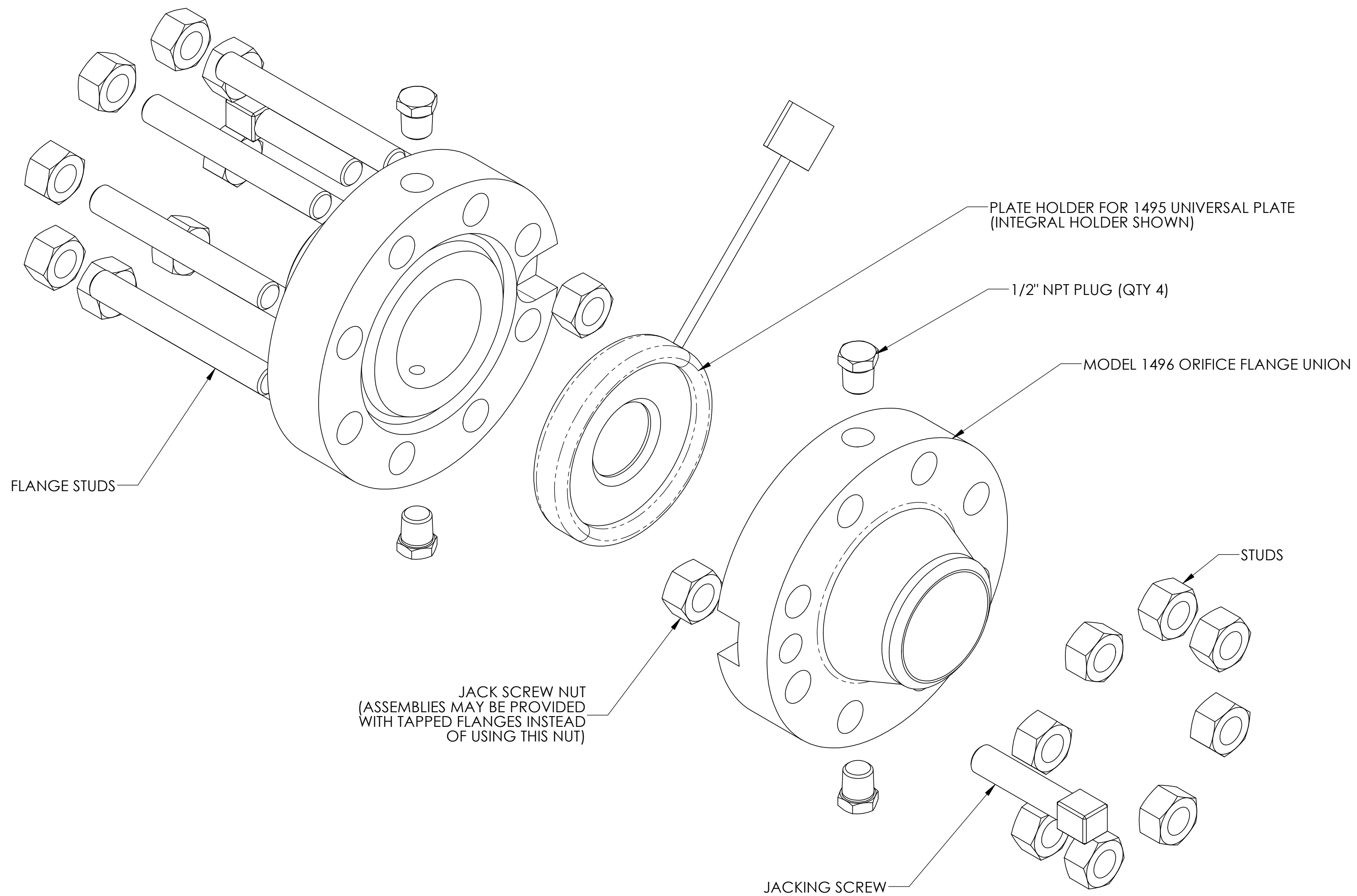

**EXPLODED VIEW OF TYPICAL INSTALLATION**

NOTE: ALL ITEMS (EXCEPT ORIFICE PLATE/HOLDER) ARE SHOWN FOR REFERENCE ONLY AND ARE NOT INCLUDED WITH THE 1495 MODEL

<b>ROSEMOUNT®</b>		
BOULDER, COLORADO		
SIZE A	FSCM.NO.	DRAWING NO. <b>01495-1003</b>
SCALE: 1:2	WT.	SHEET: 14 of 14