

Top Mount Installation for DP Flowmeters in Steam Service

This paper discusses installation of Rosemount Annubar® and Compact Primary Element products above the pipe in certain steam applications. Traditionally, DP Flowmeters in steam applications have been installed on the bottom of the pipe which was originally thought to be the best method to protect the transmitter from the temperature of the process. Under appropriate conditions, top mounting in steam does not harm the flowmeter or compromise its longevity. Compared with traditional installations below the pipe, top mounting in steam provides several key benefits:

- Reduced installation costs
- Eliminates the need for heat tracing and the associated energy costs
- Improved measurement performance at low DP measurements (between 0.75 and 2 inH₂O)
- Higher reliability and lower maintenance costs

Background

Traditionally DP Flowmeters have been installed on the bottom half of the pipe to prevent the heat of the process from overheating the transmitter and causing a failure. With the transmitter mounted below the pipe, columns of condensate formed in each of the impulse lines leading to the transmitter. These “wet legs” ensured that the transmitter was properly insulated from the process. Figure 1 shows the existing steam installation recommendation.

Figure 1: Traditional Steam DP Flowmeter Installation.

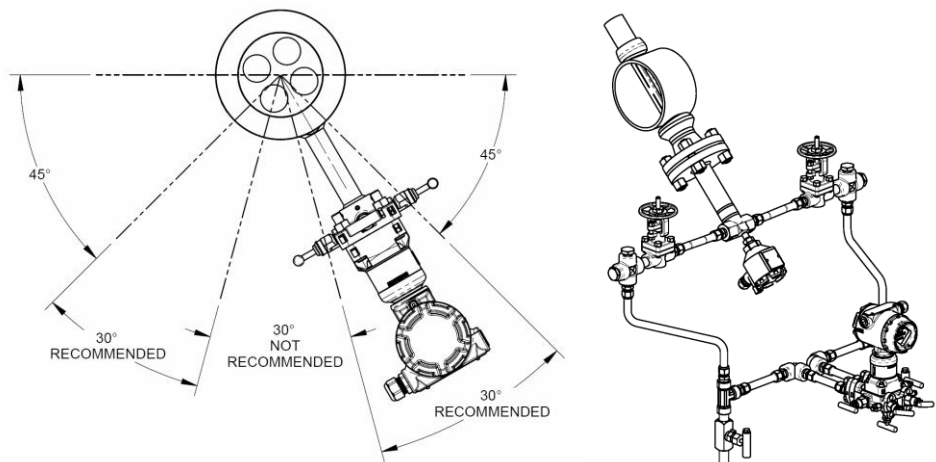

With this installation, the primary element is installed in the pipe with the instrument connection in the lower half of the pipe. From the instrument connections the impulse lines are routed downward towards the transmitter, and the wet legs isolate the transmitter from the heat of the process steam.

The most common difficulty with steam installations is the maintenance of the wet legs. At startup, the wet legs must be filled manually. If they are not filled, large flow errors will occur until enough condensate forms. During operation condensate can form at different rates in the impulse lines and inside the primary element creating inaccuracies in the DP reading. In a typical application, the user will see between .01 and 0.2 inH₂O (0.5 mbar), causing flow variations of up to 1% of full scale. This reduces the low flow repeatability and requires the user to use low flow cutoff capability in the transmitter to disable the flow totalizer and prevent large offsets in applications that experience zero flow.

Another common problem in cold climates with installation below the pipe is the tendency of the fluid in the impulse lines and near the transmitter diaphragms to freeze, causing inaccuracies or even failures as the ice expands and ruptures the transmitter diaphragm. To prevent this, steam or electrical heat tracing is used to prevent failures when pipe insulation is not sufficient. These systems typically consist of electrical heating cable, a thermostat or controller, and a power distribution panel. Heat tracing is very costly and difficult to maintain. Heat tracing is costly to install and requires frequent and ongoing maintenance.

In rare cases, when a primary element is bottom mounted in corrosive, superheated steam, the interface between the water legs and the process steam can occur in locations internal to the primary element that lead to damaging buildups of corrosive components. In these cases, there is a danger of stress corrosion cracking in the primary element. For application like this, top mounting is recommended to eliminate the possibility of a buildup of corrosive elements in the primary element.

Installation Recommendations

The recommendations for top mounting vary by product and by the temperature of the steam that is being measured. For the Annubar products, the recommended zone is shown in Figure 2. The recommended zone is within 30° from vertical up. The 30° angle allows condensate that forms in the upper transition of the Annubar sensor to efficiently drain back into the pipe. If the Annubar flowmeter is mounted closer to the horizontal, condensate does not drain properly and creates the potential for inaccurate flow measurement. Mounting directly vertical on pipe is recommended only if the steam quality is 100%. If the steam quality is not 100%, water could saturate the bottom pressure ports on the sensor which could be located as close as ¼-in. (7 mm) from the pipe inner diameter. The recommendations for the Flo-tap mounting style vary due the weight of the mounting hardware. See the Quick Installation Guides for recommendations for Flo-tap models.

Figure 2: Annubar Top Mounting for Steam Recommendations.

Recommended Zone

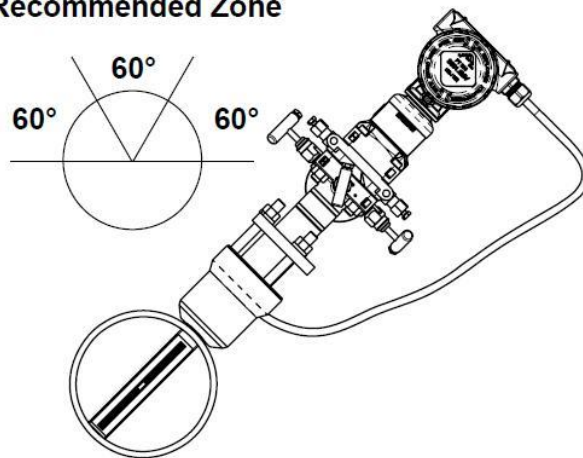

Note: If steam quality is not 100%, mount the Annubar at least 15° from the vertical position.

The temperature limits for the Annubar products in steam application are shown in Figure 3. Up to 400 °F (205 °C), the flowmeter can be installed above the pipe with a direct mounted transmitter. This is the most recommended configuration if the process is at or below this limit because it alleviates all of the common installation difficulties in steam. If the flowmeter is installed below the pipe with a direct mounted transmitter the temperature limit is 500 °F (260 °C), with a High Temperature 5-Valve Manifold option this limit is increased to 600 °F (315 °C). If the transmitter is remote mounted, the Annubar can also be mounted above or below the pipe to a limit of 850 °F (455 °C). If the 585 Severe Service Annubar is being used, the limits for mounting the flowmeter below the pipe with a remote mounted transmitter can be as high as 1200 °F (649 °C) depending on the mounting hardware and sensor material.

Figure 2: Annubar Steam Upper Temperature Limits.

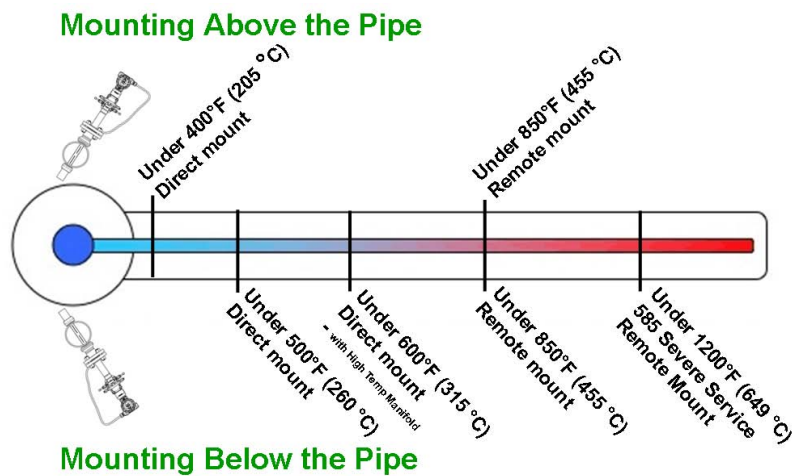

For the 405 products, the recommended zones are shown in Figure 4. The recommended zone is anywhere above 45° from horizontal. The 45° angle allows condensate that forms in the 405 neck to efficiently drain back into the pipe. Like the Annubar, if the Compact flowmeter is mounted closer to the horizontal, condensate can have difficulty draining and create the potential for inaccuracies and other problems. The 405 can be mounted directly on top because the high and low side pressure ports are located at the top of the 405 meter body. However, for differential pressure readings less than 2 inch it is not recommended to be installed directly above the pipe due to condensation sticking to the diaphragms causing errors in DP reading.

Figure 4: 405 Annubar Top Mounting for Steam Recommendations.

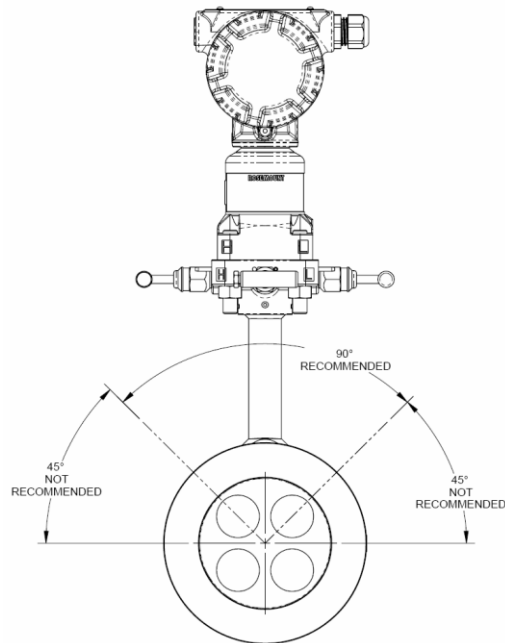

The temperature limits for the 405 products in steam application are shown in Figure 5. Up to 400 °F (205 °C), the flowmeter can be installed above the pipe with a direct mounted transmitter. This is the most recommended configuration if the process is at or below 400 °F (205 °C) because it alleviates all of the common installation difficulties in steam. If the flowmeter is installed below the pipe the temperature limit is 450 °F (232 °C), with a High Temperature 5-Valve Manifold option this limit is increased to 600 °F (315 °C). If the transmitter is remote mounted, the 405 can also be mounted above or below the pipe to a limit of 850 °F (455 °C).

Figure 5: 405 Steam Upper Temperature Limits.

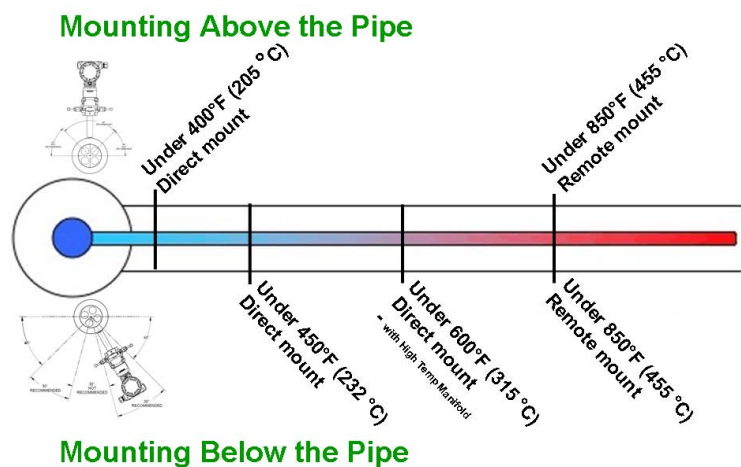

Installation Considerations

The process temperature limits for the Annubar and 405 flowmeters with a direct mounted transmitter is 400 °F (205 °C) due to the neck and connection system of the primary element. These act as a heat sink to dissipate heat, making the temperature at the transmitter within the process temperature limits of 250 °F (121 °C) at the base of the co-planar flange. The process temperature specification of most Rosemount pressure transmitters is 250 °F (121 °C) at the base of the co-planar flange. This process temperature limit is derived from an internal temperature limit of the sensor module of 185 °F (85 °C).

When the process temperatures are too high or the primary element does not have an option for direct mounting, the transmitter must be remote mounted to keep it below its process temperature limits of 250 °F (121 °C). Up to 850 °F (455 °C) the primary element can be installed on the top of the pipe with the impulse lines either routed upward toward a transmitter mounted above the pipe, or downward toward a transmitter mounted below the pipe. For these installations, the transmitter should be mounted far enough away from the pipe to keep the transmitter protected by the heat of the process. A rule of thumb is to mount the transmitter one foot away for each 100 °F (38 °C) of process temperature above 250 °F (121 °C). However, this rule of thumb does not always provide an adequate amount of protection.

For both direct and remote mount installations other factors may affect the success of the installation. These factors include: ambient temperature, type of impulse piping and connections systems, and insulation. These conditions must be considered as they could affect the process temperature limits or other sources of failures in steam applications.

First, the ambient temperature surrounding the installation must be considered. Installations in plants with little air movement or high temperature outdoor environments can lower the acceptable process temperature limits. Applications with higher ambient temperature dissipate less heat and increase the chances of overheating the transmitter.

The impulse piping and connection system in remote mount installations affect the amount of heat that is dissipated before the transmitter. Root valves are always recommended in applications with remote mounted transmitter to isolate the transmitter from the process but they also act as heat sinks in these applications. If this hardware is not used in the application longer impulse piping must be used to protect the transmitter.

The amount of insulation needed depends on the environment in which the flowmeter is installed. In general, it is recommended that pipe insulation be used

up to the instrument manifold. In environments where the ambient temperature could be below freezing, it is necessary to insulate up to the transmitter, but the transmitter itself should never be insulated. This will keep the impulse lines from freezing and eliminate the need for heat tracing. In warmer environments, it may not be necessary to insulate the impulse lines with the exception of insulation needed for personnel safety.

Application Examples

Figure 6 shows a picture of a direct mount 3051SFC mounted in a steam application above the pipe. The process temperature in this application was 365 °F (185 °C). Figure 7 shows a thermal image picture of the same installation. The temperature spot, taken at sensor module just above the connection to the primary element manifold, shows a reading of 97.5 °F (36.4 °C). This installation and 2 others like it have successfully been in operation since June 2008 in upstate New York, where temperatures in the winter months can drop as low as -20 °F (-29 °C).

Figure 6: 3051SFC with Direct Mounted transmitter, 365 °F Steam.



Figure 7: 3051SFC, 365 °F
Steam, Thermal Image.

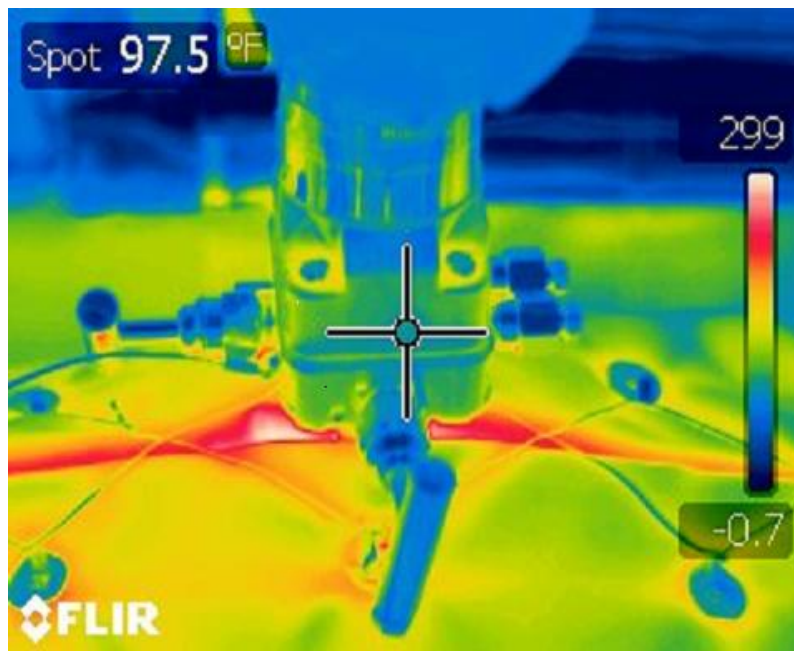

Figure 8 shows an example of a 1495 orifice plate installed on 250 °F (121 °C) saturated steam with a remote mounted transmitter. This installation has also been in operation since June 2008.

Figure 8: Remote mount
transmitter, mounted above the
pipe.



Summary and Best Practices

Whenever possible, users should utilize top mount installation for DP flowmeters in steam service, without wet legs or impulse lines. Top mounting in steam does not harm the flowmeter or compromise its longevity. Compared with traditional installations below the pipe, top mounting in steam provides several key benefits:

- Reduced installation costs
- Eliminates the need for heat tracing and the associated energy costs
- Improved measurement performance at low DP measurements (between 0.75 and 2 inH₂O)
- Higher reliability and lower maintenance costs

The contents of this publication are presented for informational purposes only, and while effort has been made to ensure their accuracy, they are not to be construed as warranties or guarantees, express or implied, regarding the products or services described herein or their use or applicability. All sales are governed by our terms and conditions, which are available on request. We reserve the right to modify or improve the designs or specifications of our products at any time without notice.

Rosemount and the Rosemount logotype are registered trademarks of Rosemount Inc.
All other marks are the property of their respective owners.

Emerson Process Management

Rosemount Inc.
8200 Market Boulevard
Chanhassen, MN 55317 USA
T (U.S.) 1-800-999-9307
T (International) (952) 906-8888
F (952) 949-7001

www.rosemount.com

© 2009 Emerson Process Management. All rights reserved.

ROSEMOUNT

www.rosemount.com



EMERSON
Process Management