

Rosemount[®] Guided Wave Radar

Mounting Instructions for Segmented Probe

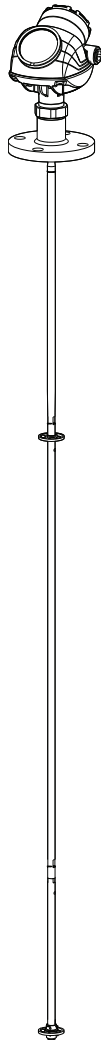

⚠ WARNING

Failure to follow safe installation and service guidelines could result in serious injury.

Make sure only qualified personnel perform installation or service.

Use the equipment only as specified in the relevant Quick Start Guide and Reference Manual:

- Rosemount 3300 Series Reference Manual (document number 00809-0100-4811)
- Rosemount 3308 Series Wireless Guided Wave Radar, 3308A Reference Manual (document number 00809-0100-4308)
- Rosemount 5300 Series Reference Manual (document number 00809-0100-4530)
- Rosemount 3300 Series Quick Start Guide (document number 00825-0100-4811)
- Rosemount 3308 Series Wireless Guided Wave Radar, 3308A Quick Start Guides (document numbers 00825-0100-4308 and 00825-0300-4308)
- Rosemount 5300 Series Quick Start Guide (document number 00825-0100-4530)

Failure to do so may impair the protection provided by the equipment.

Note

The same instructions apply for the Rosemount 3300, 3308, and 5300 Series Transmitters.

Required equipment



Standard tools, e.g. screwdriver, wrench, pliers



Anti-seize paste or PTFE tape (for NPT threaded connection)



Two support tools (supplied)



Gasket (for BSP/G threaded, flanged, and Tri Clamp connections)



Allen key (supplied)

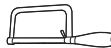

Saw

Contents

Required equipment	2	Assemble the segmented probe	5
Segmented probe parts	3	Adjust the probe length	17
Verify probe length	4		

Segmented probe parts

Dimensions are in inches (mm).

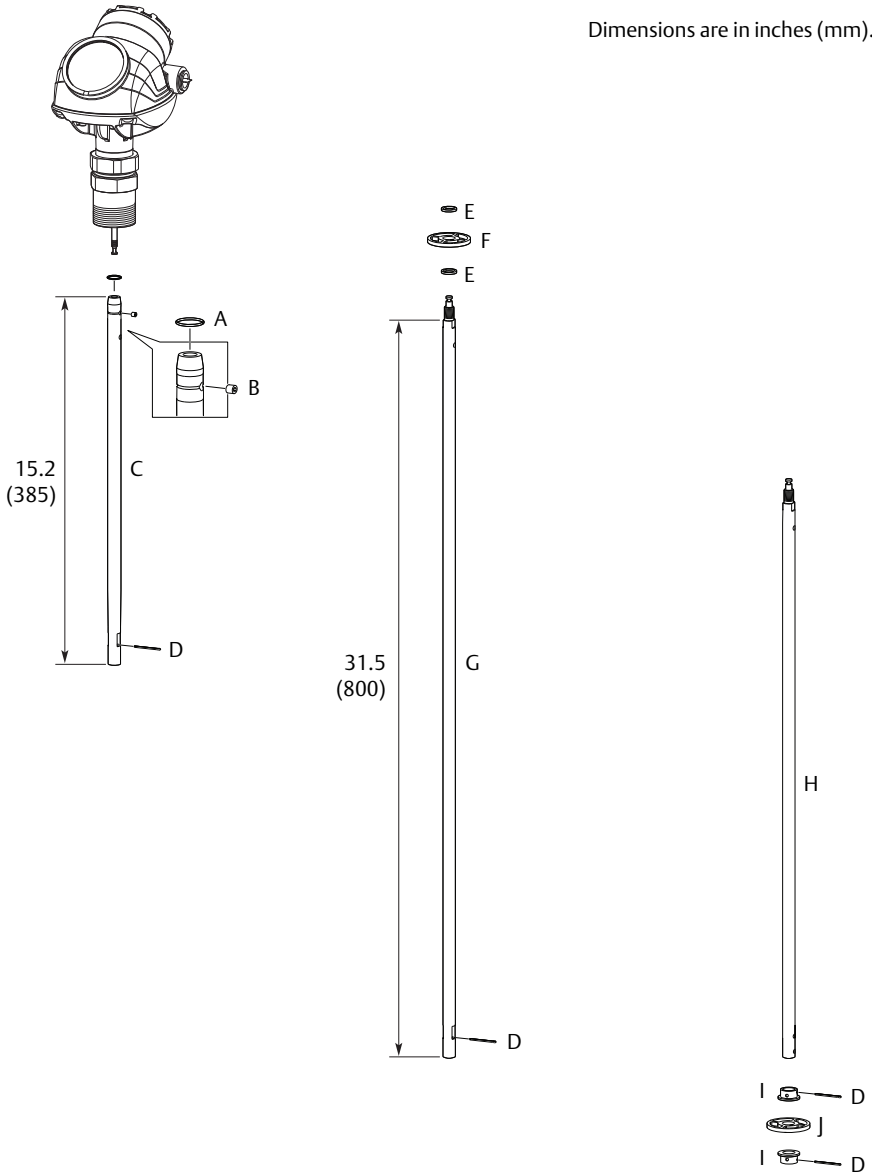

- A. Safety ring
- B. Screw
- C. Top segment
- D. Split pin
- E. PTFE washer (optional)
- F. Centering disc in PTFE (optional)
- G. Middle segment
- H. Bottom segment (length varies depending on total probe length)
- I. Bushing (for the centering disc at the probe end)
- J. Bottom centering disc in PTFE or Stainless Steel (optional)

Verify probe length

Segmented probe ordered with model code 4S

Before installation, verify the probe length (L) on the label. If the probe length needs to be adjusted, see “Adjust the probe length” on page 17.

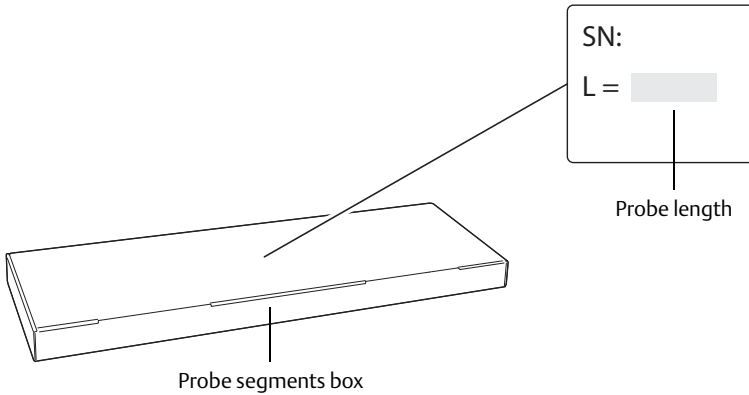

Segmented probe ordered as spare part kit

Before installation, the number of segments that add up to the desired probe length must be determined. Also, the bottom segment may need to be shortened. See “Adjust the probe length” on page 17.

Assemble the segmented probe

Note

If there is enough space beside the tank, the probe can be assembled before inserting it into the tank.

1. Insert the stop screw to the top segment. Tighten approximately 2 turns.

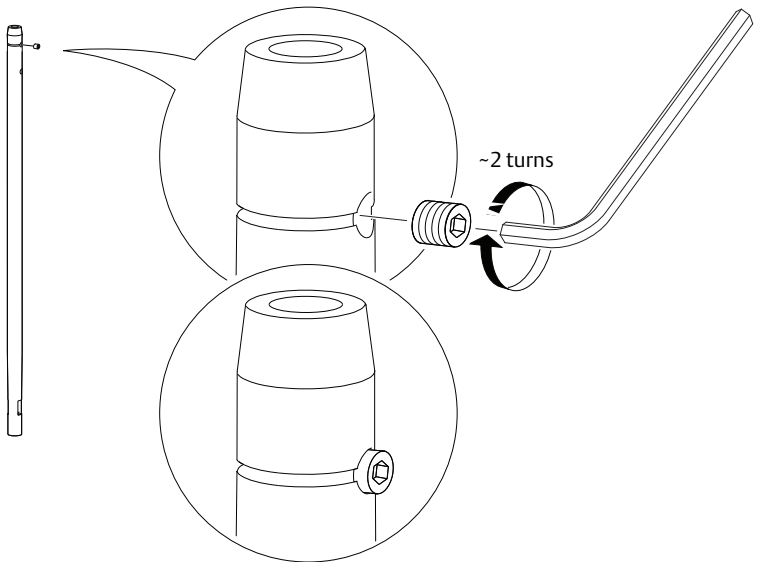
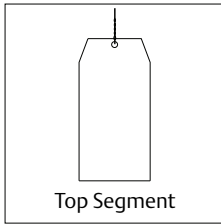

2. Pre-assemble the safety ring.

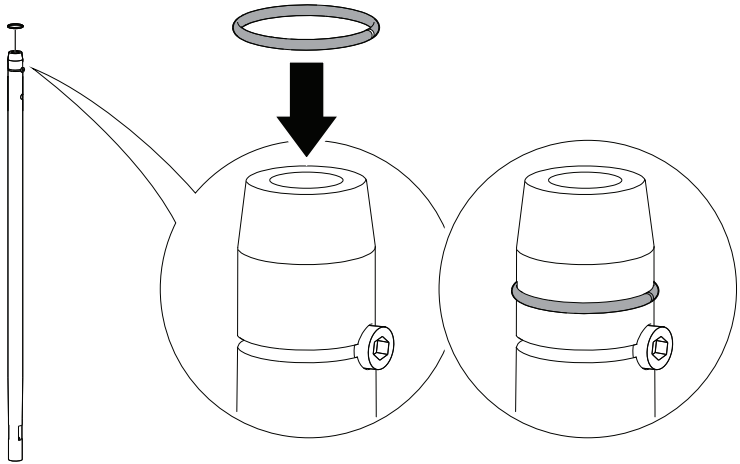

3. **Optional:** If ordered, mount the centering disc on the bottom segment of the probe.

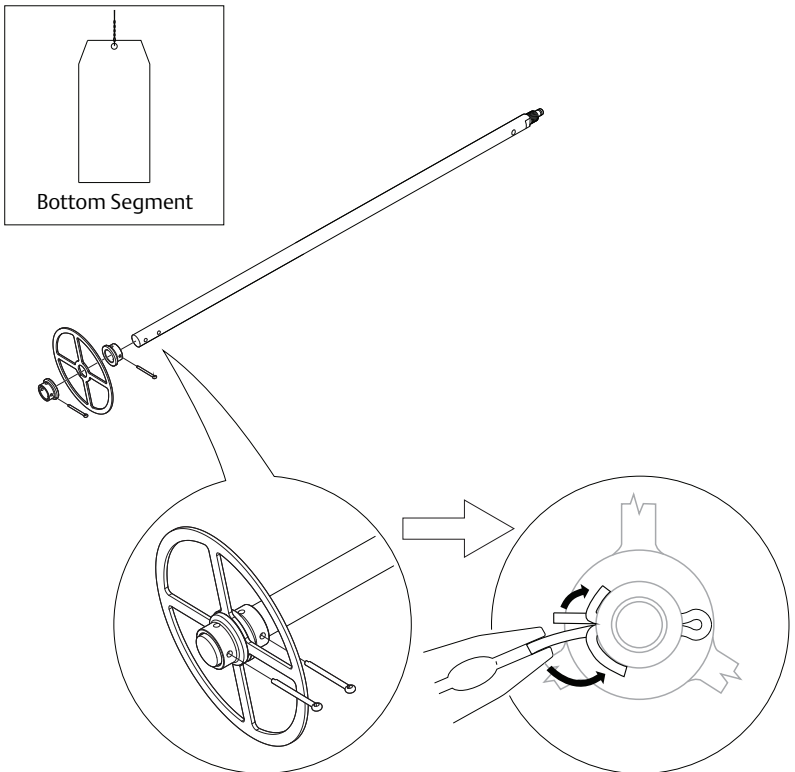

4. Insert the support tool.

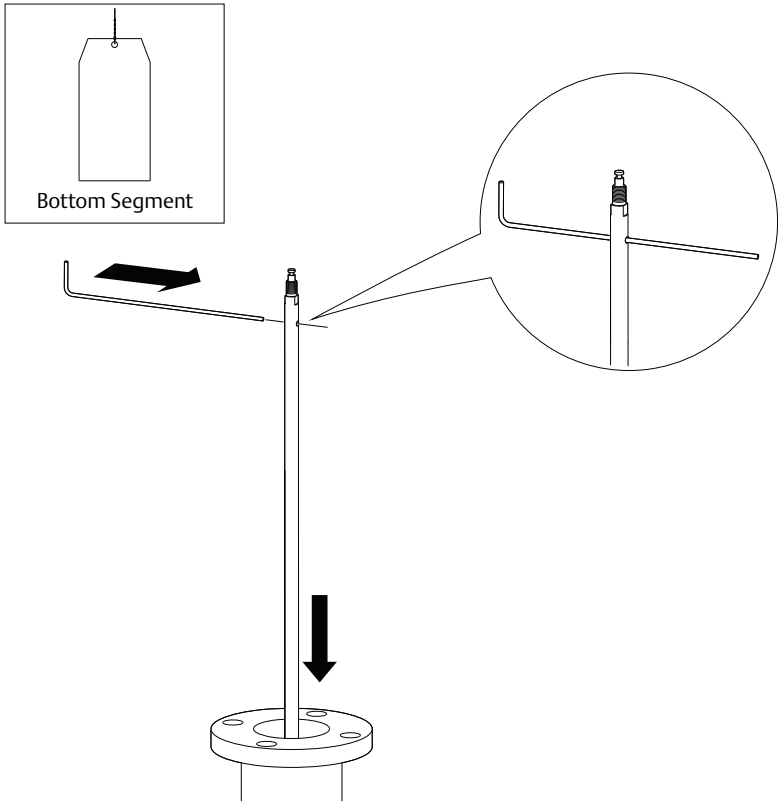

5. **Optional:** If ordered, mount the centering disc.

Note

- Maximum five pcs/probe
- Minimum two segments between each centering disc

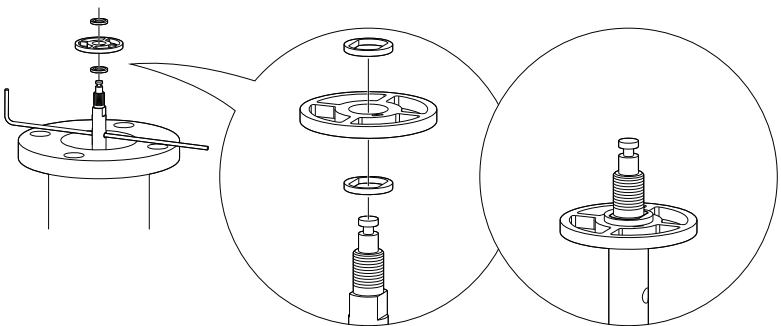

6. Mount a middle segment.

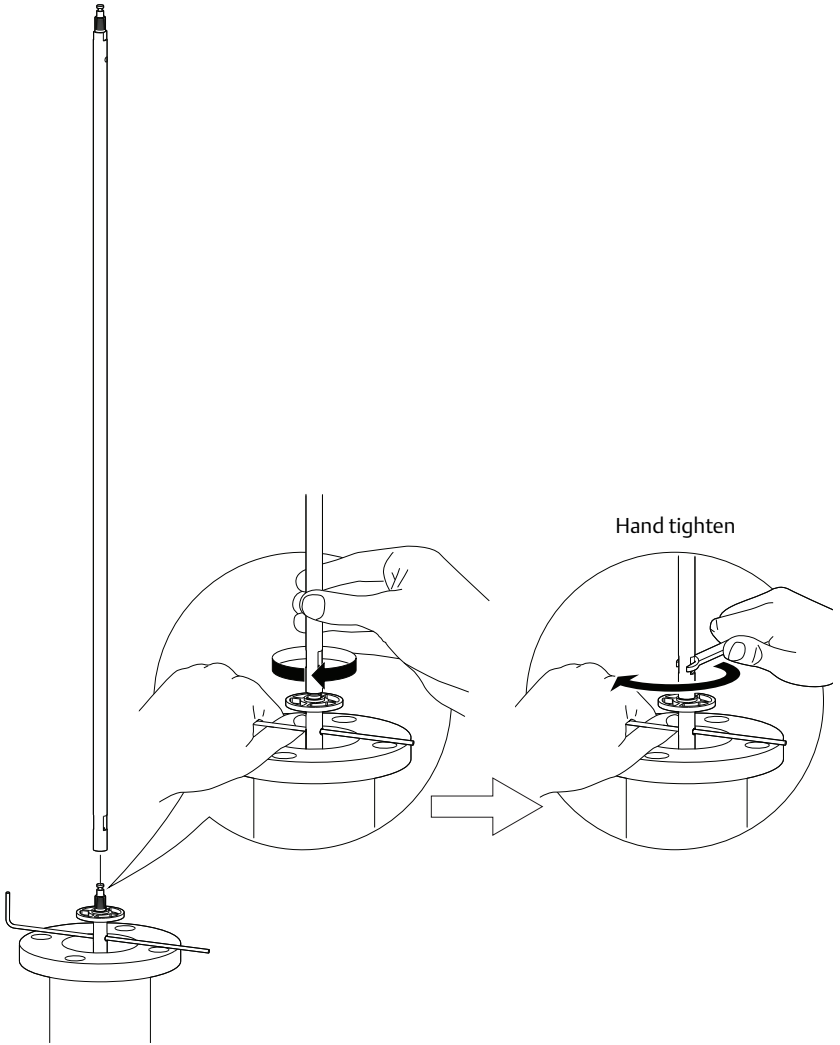

7. Secure the split pin.

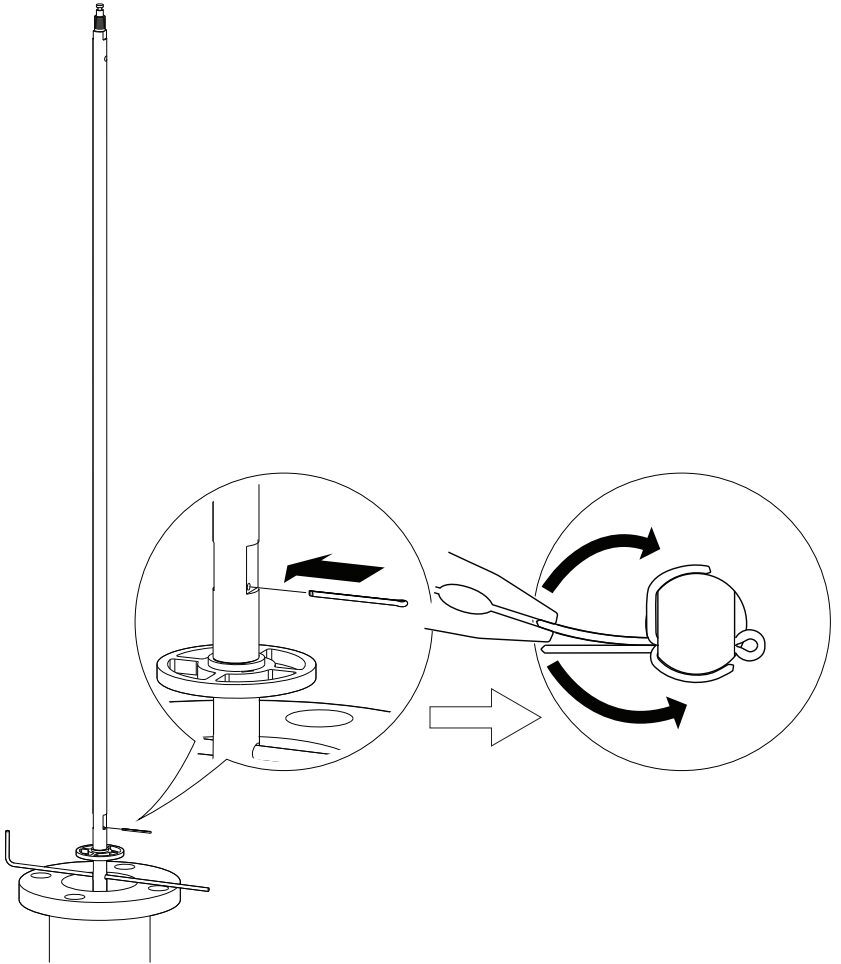

8. Insert the second support tool.

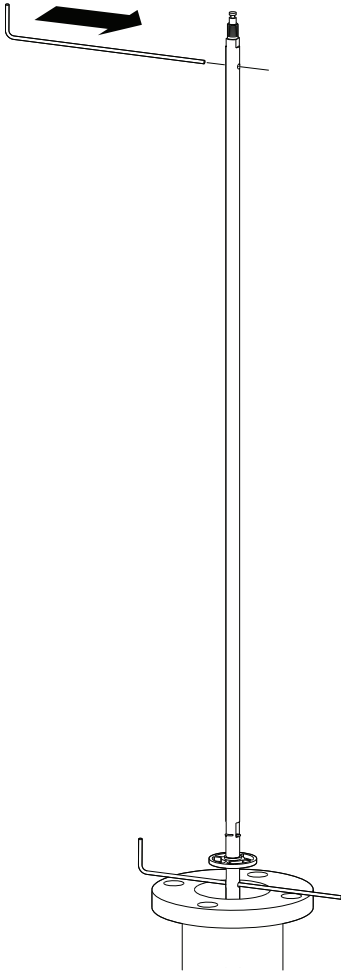

9. Remove the first support tool and lower the probe into the tank.

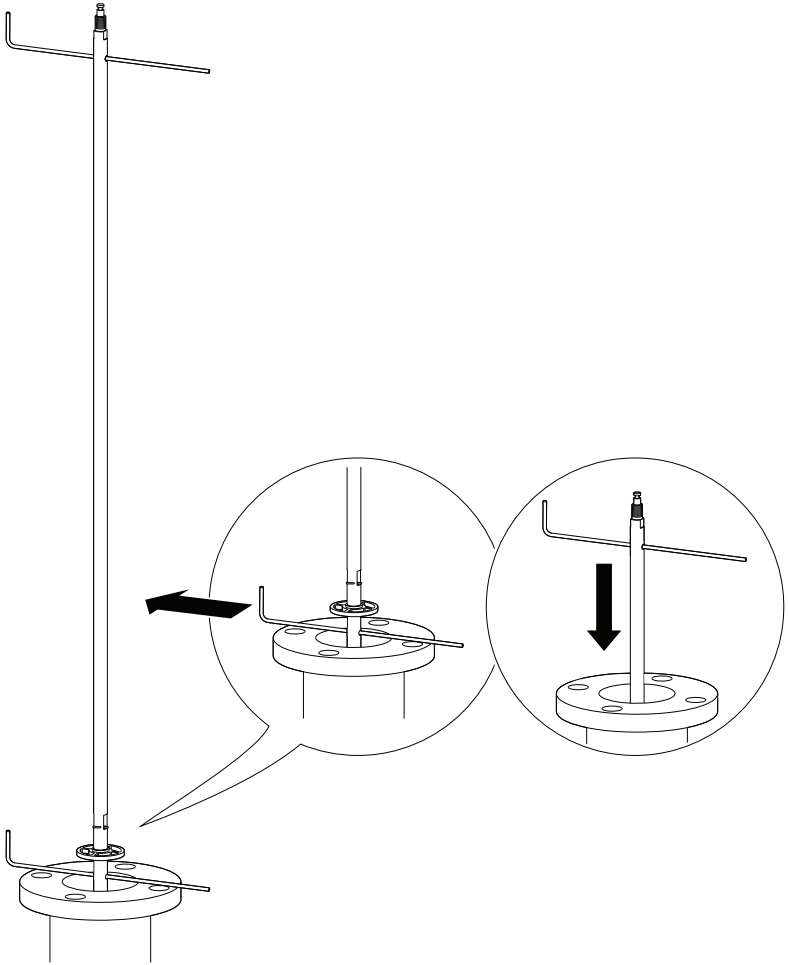

10. Repeat steps 5 to 9 until all segments are mounted. Make sure to finish with the top segment of the probe.

11. Seal and protect threads.

⚠ Only for NPT threaded tank connection.

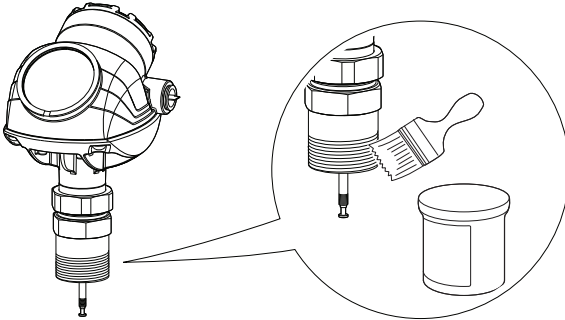

Use anti-seize paste or PTFE tape according to your site procedures.

12. Attach the probe to the device.

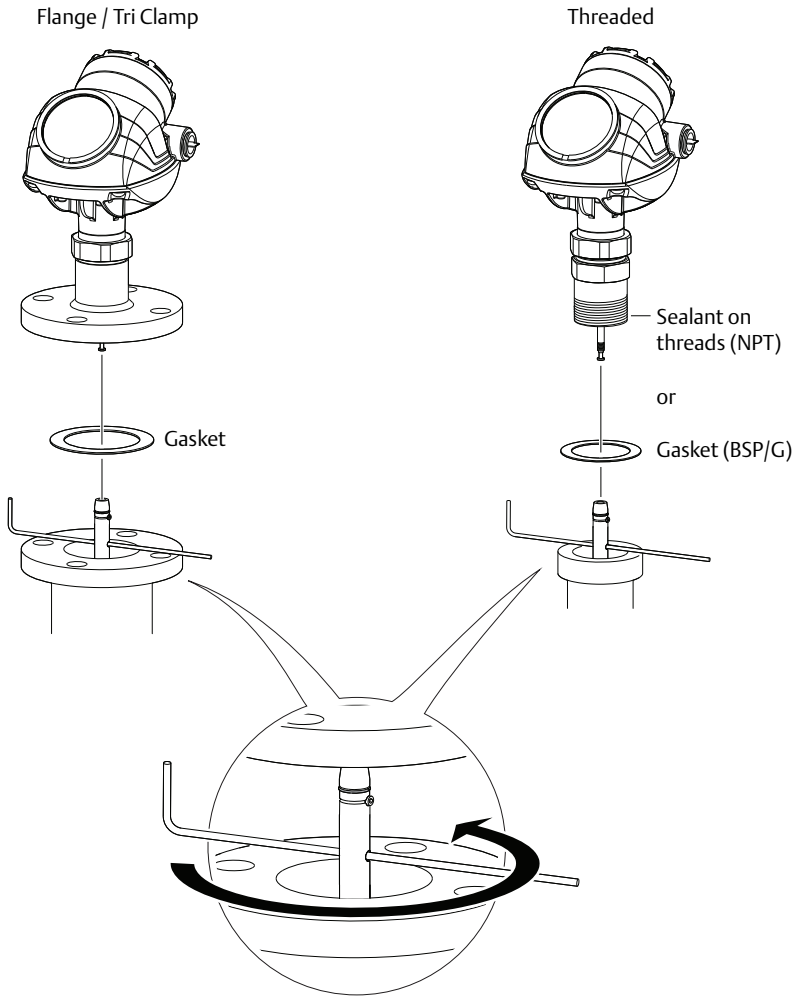

Note

For safety reasons, at least two people are needed when mounting the device.

Make sure to hold the device above the tank. High loads can break the support tool.

13. Tighten the stop screw and slide the safety ring into the groove.

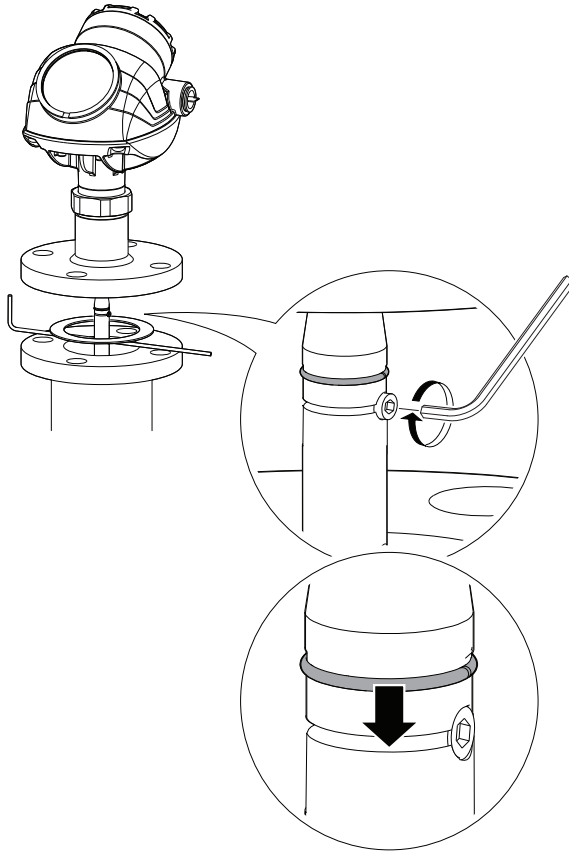

14. Remove the support tool.

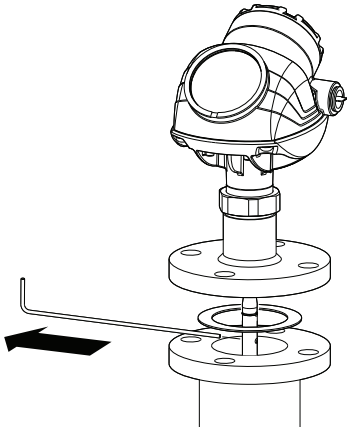

15. Mount the device on the tank.

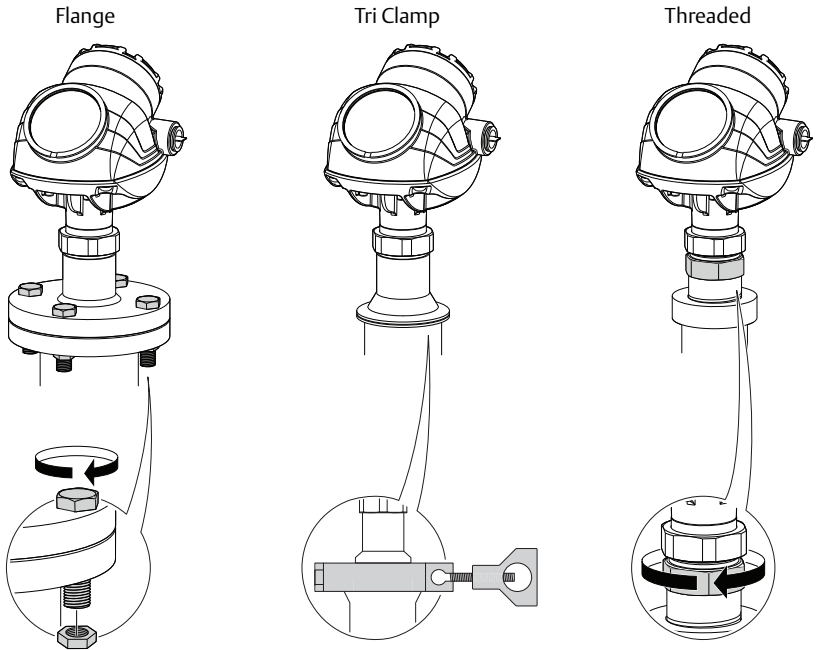

16. Rotate the housing to the desired direction.

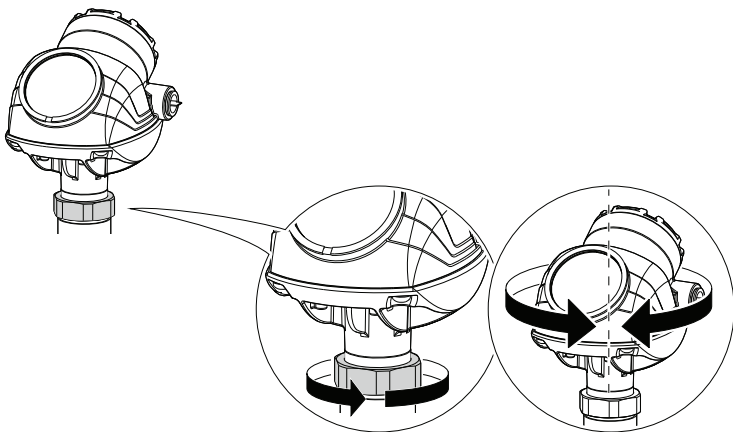

17. Tighten the nut. The torque must be 30 Lbft (40 Nm).

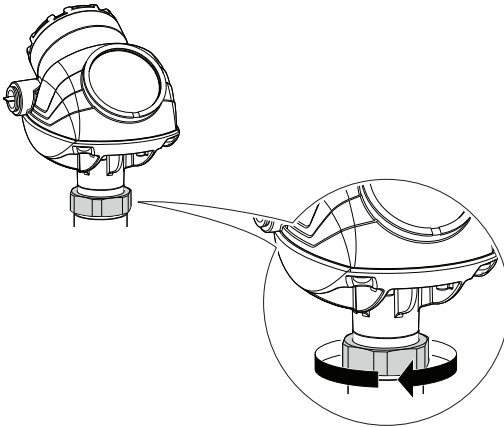

18. For the 3300 and 5300, connect the wiring.

For further instructions, see the Rosemount 3300 Series (document number 00825-0100-4811) and the Rosemount 5300 Series (document number 00825-0100-4530) Quick Start Guides.

19. For the 3308A, insert power module and connect to device.

For further instructions, see the Rosemount 3308 Series Wireless Guided Wave Radar, 3308A Quick Start Guides (document numbers 00825-0100-4308 and 00825-0300-4308).

Adjust the probe length

1. Determine L , the desired probe length.

L , desired probe length:

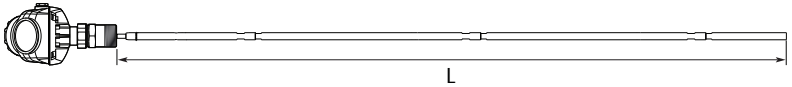

2. Determine n , the number of middle segments needed for the desired probe length. See [Table 1](#) and [Table 2](#) on page 19.

n , number of middle segments:

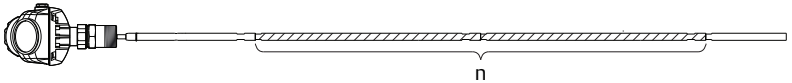

3. Calculate Y , the length of the bottom segment. See [Table 1](#) and [Table 2](#) on page 19.

Y , length of bottom segment:



4. Continue as follows:

Length of bottom segment (Y)	Action
<p>$Y < 0.4$ in. (10 mm)</p>	<ul style="list-style-type: none"> • Continue with step (7). Do not use the bottom segment.
<p>$Y \geq 0.4$ in. (10 mm)</p>	<ul style="list-style-type: none"> • Continue with step (5) and cut the bottom segment.
<p>$Y = 31.5$ in. (800 mm)</p>	<ol style="list-style-type: none"> 1. Add one extra middle segment to the calculated n. 2. Continue with step (7).

5. Mark where to cut the bottom segment.

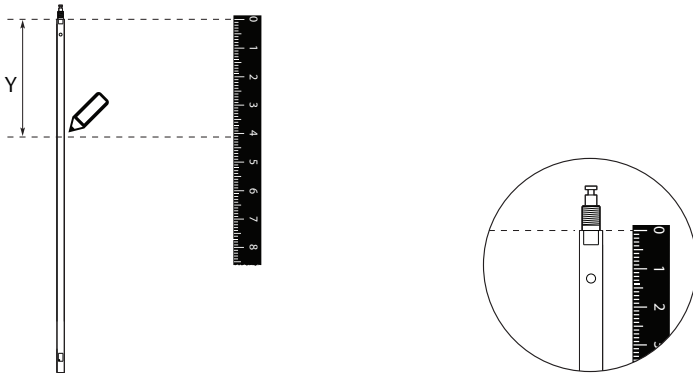

6. Cut the bottom segment at the mark.

Note

Make sure the bottom segment is fixed while cutting.

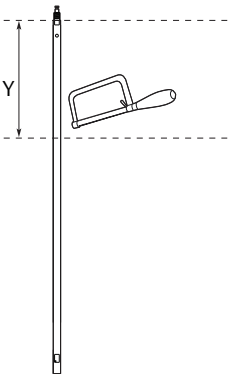

7. **Optional:** If a bottom centering disc is ordered, then drill two holes on the bottom segment using the drilling fixture.

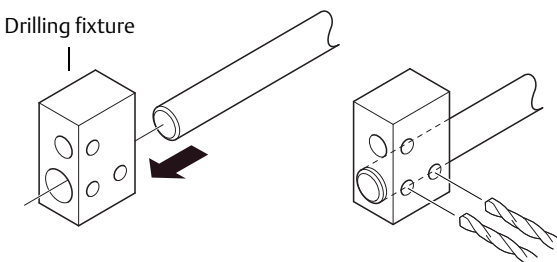

Table 1. Determination of Probe Segments for Standard Seal

Desired probe length (L) ⁽¹⁾		Number of middle segments (n)	Length of bottom segment (Y)	
in.	mm		in.	mm
15.8 ≤ L ≤ 47.2	400 ≤ L ≤ 1200	0 pc	Y = L - 15.8	Y = L - 400
47.2 < L ≤ 78.7	1200 < L ≤ 2000	1 pc	Y = L - 47.2	Y = L - 1200
78.7 < L ≤ 110.2	2000 < L ≤ 2800	2 pcs	Y = L - 78.7	Y = L - 2000
110.2 < L ≤ 141.7	2800 < L ≤ 3600	3 pcs	Y = L - 110.2	Y = L - 2800
141.7 < L ≤ 173.2	3600 < L ≤ 4400	4 pcs	Y = L - 141.7	Y = L - 3600
173.2 < L ≤ 204.7	4400 < L ≤ 5200	5 pcs	Y = L - 173.2	Y = L - 4400
204.7 < L ≤ 236.2	5200 < L ≤ 6000	6 pcs	Y = L - 204.7	Y = L - 5200
236.2 < L ≤ 267.7	6000 < L ≤ 6800	7 pcs	Y = L - 236.2	Y = L - 6000
267.7 < L ≤ 299.2	6800 < L ≤ 7600	8 pcs	Y = L - 267.7	Y = L - 6800
299.2 < L ≤ 330.7	7600 < L ≤ 8400	9 pcs	Y = L - 299.2	Y = L - 7600
330.7 < L ≤ 362.2	8400 < L ≤ 9200	10 pcs	Y = L - 330.7	Y = L - 8400
362.2 < L ≤ 393.7	9200 < L ≤ 10000	11 pcs	Y = L - 362.2	Y = L - 9200

1. Maximum probe length is 19 ft 8 in. (6 m) for the 3300 Series and 32 ft 9 in. (10 m) for the 3308 and 5300 Series.

Table 2. Determination of Probe Segments for HTHP/HP/C Seal

Desired probe length (L) ⁽¹⁾		Number of middle segments (n)	Length of bottom segment (Y)	
in.	mm		in.	mm
17.3 ≤ L ≤ 48.8	440 ≤ L ≤ 1240	0 pc	Y = L - 17.3	Y = L - 440
48.8 < L ≤ 80.3	1240 < L ≤ 2040	1 pc	Y = L - 48.8	Y = L - 1240
80.3 < L ≤ 111.8	2040 < L ≤ 2840	2 pcs	Y = L - 80.3	Y = L - 2040
111.8 < L ≤ 143.3	2840 < L ≤ 3640	3 pcs	Y = L - 111.8	Y = L - 2840
143.3 < L ≤ 174.8	3640 < L ≤ 4440	4 pcs	Y = L - 143.3	Y = L - 3640
174.8 < L ≤ 206.3	4440 < L ≤ 5240	5 pcs	Y = L - 174.8	Y = L - 4440
206.3 < L ≤ 237.8	5240 < L ≤ 6040	6 pcs	Y = L - 206.3	Y = L - 5240
237.8 < L ≤ 269.3	6040 < L ≤ 6840	7 pcs	Y = L - 237.8	Y = L - 6040
269.3 < L ≤ 300.8	6840 < L ≤ 7640	8 pcs	Y = L - 269.3	Y = L - 6840
300.8 < L ≤ 332.3	7640 < L ≤ 8440	9 pcs	Y = L - 300.8	Y = L - 7640
332.3 < L ≤ 363.8	8440 < L ≤ 9240	10 pcs	Y = L - 332.3	Y = L - 8440
363.8 < L ≤ 393.7	9240 < L ≤ 10000	11 pcs	Y = L - 363.8	Y = L - 9240

1. Maximum probe length is 19 ft 8 in. (6 m) for the 3300 Series and 32 ft 9 in. (10 m) for the 3308 and 5300 Series.



Global Headquarters

Emerson Process Management

6021 Innovation Blvd.

Shakopee, MN 55379, USA

+1 800 999 9307 or +1 952 906 8888

+1 952 949 7001

RFQ.RMD-RCC@EmersonProcess.com

North America Regional Office

Emerson Process Management

8200 Market Blvd.

Chanhassen, MN 55317, USA

+1 800 999 9307 or +1 952 906 8888

+1 952 949 7001

RMT-NA.RCCRFQ@Emerson.com

Latin America Regional Office

Emerson Process Management

1300 Concord Terrace, Suite 400

Sunrise, Florida, 33323, USA

+1 954 846 5030

+1 954 846 5121

RFQ.RMD-RCC@EmersonProcess.com

Europe Regional Office

Emerson Process Management Europe GmbH

Neuhofstrasse 19a P.O. Box 1046

CH 6340 Baar

Switzerland

+41 (0) 41 768 6111

+41 (0) 41 768 6300

RFQ.RMD-RCC@EmersonProcess.com

Asia Pacific Regional Office

Emerson Process Management Asia Pacific Pte Ltd

1 Pandan Crescent

Singapore 128461

+65 6777 8211

+65 6777 0947

Enquiries@AP.EmersonProcess.com

Middle East and Africa Regional Office

Emerson Process Management

Emerson FZE P.O. Box 17033,

Jebel Ali Free Zone - South 2

Dubai, United Arab Emirates

+971 4 8118100

+971 4 8865465

RFQ.RMTMEA@Emerson.com

Standard Terms and Conditions of Sale can be found at:
www.rosemount.com/terms_of_sale.

The Emerson logo is a trademark and service mark of Emerson Electric Co. Rosemount and Rosemount logotype are registered trademarks of Rosemount Inc.

All other marks are the property of their respective owners.

© 2015 Rosemount Inc. All rights reserved.