

# Rosemount 3490 Series Universal Control Unit

The 3490 series of wall and panel mount control units provide comprehensive control functionality for any 4-20mA or HART compatible transmitter.

### **THE 3490 SERIES FEATURES:**

- *IS Power Supply to transmitter*
- *4-20mA / HART input*
- *Isolated 4-20mA output*
- *Five Control relays*
- *Multi-function back lit display*
- *Wall or panel mount*
- *Pre-programmed linearization - volume and open channel flow*



## Contents

Introduction . . . . .	page Accessories-2
Features and applications . . . . .	page Accessories-2
Transmitter capability . . . . .	page Accessories-3
3492 differential level system. . . . .	page Accessories-3
3493 flow logging system. . . . .	page Accessories-3
The menu system. . . . .	page Accessories-4
About parameters. . . . .	page Accessories-5
Other features . . . . .	page Accessories-5
Set-up procedure . . . . .	page Accessories-7
Technical specification . . . . .	page Accessories-8
Dimensional drawings . . . . .	page Accessories-10
Product certifications . . . . .	page Accessories-13
Ordering information . . . . .	page Accessories-14

## INTRODUCTION

The 3490 series of wall and panel mount control units provide comprehensive control functionality for any 4-20mA or HART compatible transmitter.

Mounted in a non-hazardous area, the 3490 provides a protected (IS) 24V dc power supply to a transmitter that may be installed in a hazardous area.

A back-lit display gives clear visual indication of the measured value and status of all inputs and outputs.

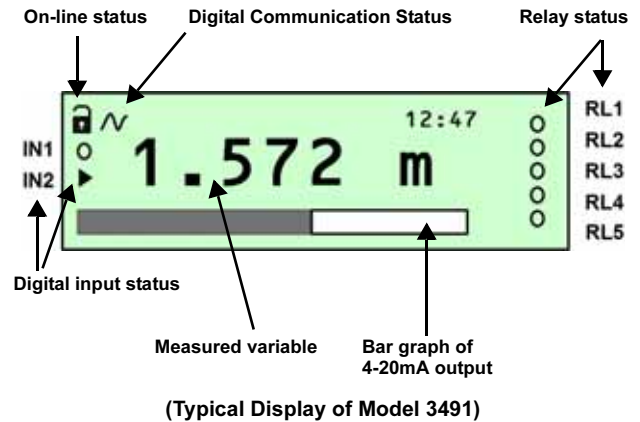
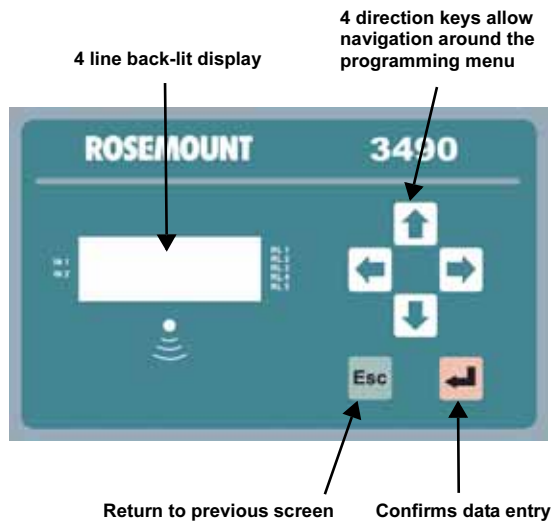

## FEATURES AND APPLICATIONS

- Accepts any 4-20mA or HART compatible input, allowing standardization of control room layout.
- Tough polycarbonate NEMA4X or IP65 wall mount enclosure options for internal or external mounting.
- Control units are 115/230V ac powered or 24V dc powered. Both versions provide an Intrinsically Safe 24V dc power supply to the transmitter.
- Supports two voltage-free contact closure inputs, allowing override of control functions on external triggers.
- Pre-programmed tank shapes, flow algorithms and pump control routines simplify configuration.
- A 20-point user programmable facility is provided for non-standard applications.
- Real time clock allows energy saving routines and pump efficiency calculations.
- Five voltage-free SPDT (SPCO) relays for alarm and control duties.
- 4-20mA 12-bit isolated current output proportional to calculated value.
- Clear visual display of measured value with units and relay status. Also used to guide user through programming menu.
- Wizard assisted programming, with password protection to prevent unauthorized access.
- 3492 model also accepts input from two transmitters and performs sum or differential calculations, providing a single current output proportional to the answer.
- 3493 model also provides on-board logging of PV and totalized flow values in flow measurement applications

The 3490 is configured and interrogated using an integral 6 button keypad and an easy to navigate menu structure (page Accessories-4).

Many popular configurations are “Wizard assisted”, enabling fast and accurate programming (page Accessories-7).

The HART digital or 4-20mA analog signal from the transmitter may be offset, dampened, scaled, and linearized as required. A range of pre-programmed linearization algorithms are user selectable.

Typical measurements include level, volume and distance measurement, as well as open channel flow measurement in wide range of flumes and weirs.

The 4-20mA output signal may also be scaled to re-transmit all or just part of the input signal or calculated value.

Five relays are provided and are fully field programmable to perform a wide variety of control, fault indication or alarm duties.

## Product Data Sheet

00813-0100-4841, Rev. AA  
Catalog 2008 - 2009

# Rosemount 3490 Series

## TRANSMITTER CAPABILITY

When a Rosemount 3100 Series or 3300 Series (non-explosion proof version) HART transmitter is connected, the 3490 will recognize the transmitter, allow selection of variables to be processed, and allow full access to and programming of the transmitter configuration parameters, eliminating the need for any other HART programming device.

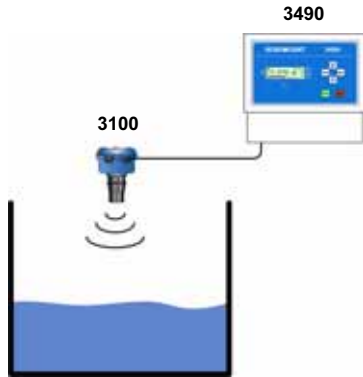

Any other HART transmitter can be connected to the 3490. In this case, the 3490 will recognize the transmitter as an "unknown instrument" and will allow access to and programming of the Universal and Common Practice HART commands.

3490 Control Units will operate with any 2 wire 4-20mA transmitter, providing power to the loop. In the case of I.S. transmitters mounted in hazardous areas, the power supply is fully protected and there is no need for any external I.S. barrier.

## 3492 DIFFERENTIAL LEVEL SYSTEM

It is sometimes necessary to know the difference in two levels, for example, across an inlet screen where the level difference is an indicator of the state of the screen.

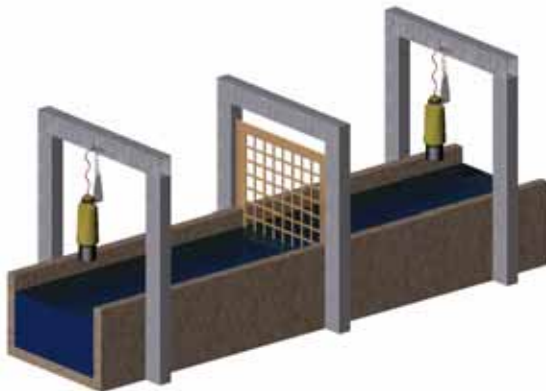

The Rosemount 3492 differential level system is designed to operate with two HART level transmitters, and can be programmed to perform calculations on the two input signals –

- Level, volume, or flow under transmitter 1
- Level, volume, or flow under transmitter 2
- Level difference between transmitter 1 and 2
- Sum of the level, volume, or flow under both transmitters

The control relays and current output can be driven by any of these functions, and the display can be configured to show the reading of each transmitter plus either the difference or the sum of the readings.

The transmitters used in this application are fully HART compliant, and are connected in parallel on a simple two-wire bus.

## 3493 FLOW LOGGING SYSTEM

In many instances, it is required that the flow and totalized flow be logged for download at a later date.



The Rosemount 3493 flow logging system has an on-board logger which can log up to 7000 samples at user definable intervals.

In the event of flow exceeding a customer specified limit value, fast logging is automatically triggered until the flow reverts to normal.

In addition, 365 daily totalized flow values are also logged along with the maximum instantaneous flow during each 24 hour period.

A second totalizer is provided to totalize cumulative flow through the flow structure.

All data is real time stamped and stored for download via an RS232 connection on the 3493 control unit.

Data can be collected using a portable PC, and is easily stored and manipulated using windows-based software.

## THE MENU SYSTEM

The integral menu system is entered from the Primary Display by using the red (Enter) button on the front panel keypad.

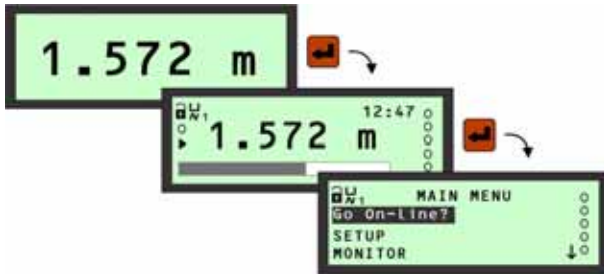

Here you will find the top-level of a hierarchical menu structure, which is organized like a tree structure.

This top level menu, known as the MAIN MENU, leads to further menus (branches), and these sub-menus lead to application parameters.

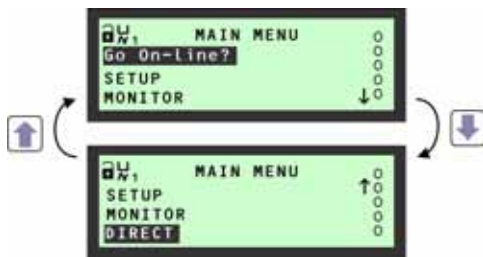

Navigation from menu option to menu option is by using the arrow-buttons.

Selecting a menu option is by using the red (Enter) button when the option is highlighted.

The MAIN MENU leads to SETUP and MONITOR menus for configuring and viewing application parameters of the 3490, and one or two (depending on the model) HART transmitters.

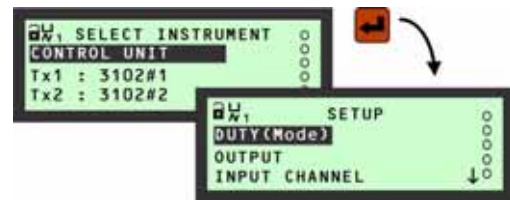

(3492 screens shown with Rosemount 3102 transmitters)

The 3490's SETUP menu leads to control unit parameters for:

- Duty selection e.g. open channel flow.
- Setting up inputs.
- Setting up outputs.
- Logging (on model 3493).
- Totalizing (including daily totalizer on model 3493).
- RS232 Communications (for data logging on model 3493).
- Operational parameters.

Menu options vary between different models of the 3490 Control Unit.

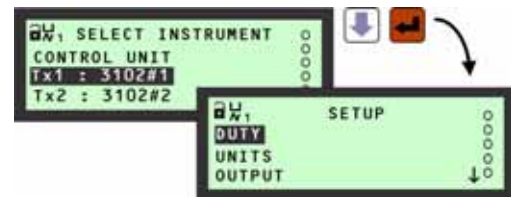

(3492 screens shown with Rosemount 3102 transmitter)

Similarly, the transmitter SETUP menu leads to transmitter specific parameters. Actual menu options vary between the different HART transmitters.

The 3490's MONITOR menu leads to control unit parameters for:

- Primary Value (as seen on typical 3491 display).
- Secondary Value (SV), Tertiary Value (TV), and Fourth Value (FV)
- Totalizer Values.
- Relay data.
- Alarm and Fault Reports.
- Diagnostic data.

Similarly, the transmitter MONITOR menu leads to transmitter specific parameters. Actual menu options vary between the different HART transmitters.

## Product Data Sheet

00813-0100-4841, Rev. AA  
Catalog 2008 - 2009

# Rosemount 3490 Series

## ABOUT PARAMETERS

Upon entering a parameter screen, it is in **View Mode** (Figure 1).

Figure 1.

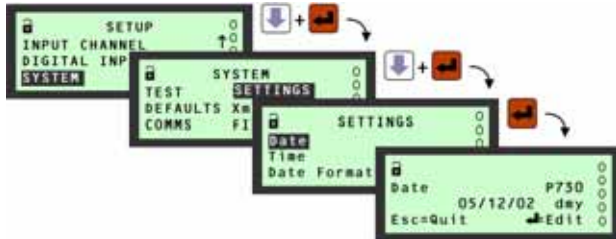

Guidance for what to do now is on the Display Line 4. On parameter screens, the **ESC** button returns you to the previous menu, and the red (Enter) button will enter **Edit Mode** or start an activity.

Figure 2.



The "0" is highlighted (reverse video) to show this digit can now be edited (Figure 2). Also, note that on Display Line 4, "Edit" has changed to be "Save".

You can press the **ESC** button at any time to quit editing and return to View Mode. This will also restore the original setting.

Use the **RIGHT-ARROW** button once to highlight the digit to the right, in this case "5". (The **LEFT-ARROW** button is for moving left).

Use the **UP-ARROW** button to scroll through 0-9, and a decimal point. (The **DOWN-ARROW** button scrolls down through the numbers). Similarly, when a parameter has a multiple-choice list of options, the arrow buttons scroll through these options.

Figure 3.

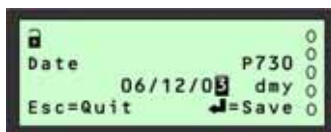

Press the red (ENTER) button to save the new date and return to View Mode, and then press the **ESC** button to return to the menu.

## OTHER FEATURES

### On-line / Off-line Modes



An *open padlock* icon indicates the 3490 is presently in the **off-line mode**. In this mode, the unit can be programmed providing that you know the security PIN (if set-up).

Additionally in off-line mode, the 4-20mA output is frozen and all relays are frozen unless allocated to totalizing and sampler duties. Fault relays are de-energized.



A *closed padlock* icon indicates that the 3490 is presently in the **on-line mode**. In this mode, most of the unit cannot be programmed. However, you will be prompted to go off-line if you attempt to programme whilst in this mode and providing that you know the security PIN (if set-up).

Additionally in on-line mode, the 4-20mA output and all relays are enabled.

### PIN Security

Personal Identification Number (PIN) security prevents unauthorized people from programming the 3490 Series Control Unit. Typically, this is set-up when all the other programming has been completed. As with bankcards, there is one PIN number.

### Relay States

Relay outputs 1 to 4 are normally On Point / Off Point control relays which may be used to start/stop pumps or open/close valves at different levels. They normally energize at one level and de-energize at a different level.

Alternatively, they can be programmed as out-of-limit alarms; they de-energize between defined points and will energize outside those points. On models 3491 and 3492, they may also be programmed to perform a variety of auto-sequences and auxiliary functions, such as pump-down operations, pump rotations to equalize wear, and de-sludge/cleaning.

Relay output 5 is normally a fail safe fault relay but may be re-allocated to another duty.

The relay status icons on the primary display have the following meanings:

o = de-energized, ▶ = energized, A = Alarm duty, S = Sampler duty, T = Totalizing duty.

# Rosemount 3490 Series

---

## Display Configuration Options

The factory default configuration of the display can be changed to show different graphic and text information. Three areas of the display can be re-configured:

- Upper display
- Middle display
- Lower display

## Alarms

The 3490 can detect the following alarm conditions:

- Primary Value out-of-limits.
- Current Output saturated
- Logging memory filling (model 3493 only).
- Logging memory full (model 3493 only).
- Current Input saturated.
- Rising liquid level.
- Relay alarms.
- Low pump efficiency (models 3491/3492 only).

## Digital Inputs IN1 and IN2

Digital inputs IN1 and IN2 can be individually set-up to perform an action whenever they are activated:

- Raise an alarm.
- Go Offline.
- Freeze totalizer.
- Freezer Primary Value.
- Suppress alarms.
- Display Message.
- Log Input.
- Start pump-down.
- Lock parameters.
- Protect totalizer.
- Reset totalizer.

# Product Data Sheet

00813-0100-4841, Rev. AA  
 Catalog 2008 - 2009

# Rosemount 3490 Series

## SET-UP PROCEDURE

The set-up procedure is simplified by easy-to-use Wizards. By following a sequence of on-screen prompts, an individual function or a large application can be easily set-up without fuss.

- DUTY Wizard.
- TOTALIZER Wizard.
- LOGGING Wizard.
- RELAY Wizard.
- TRANSMITTER (Find/Remove) Wizard.

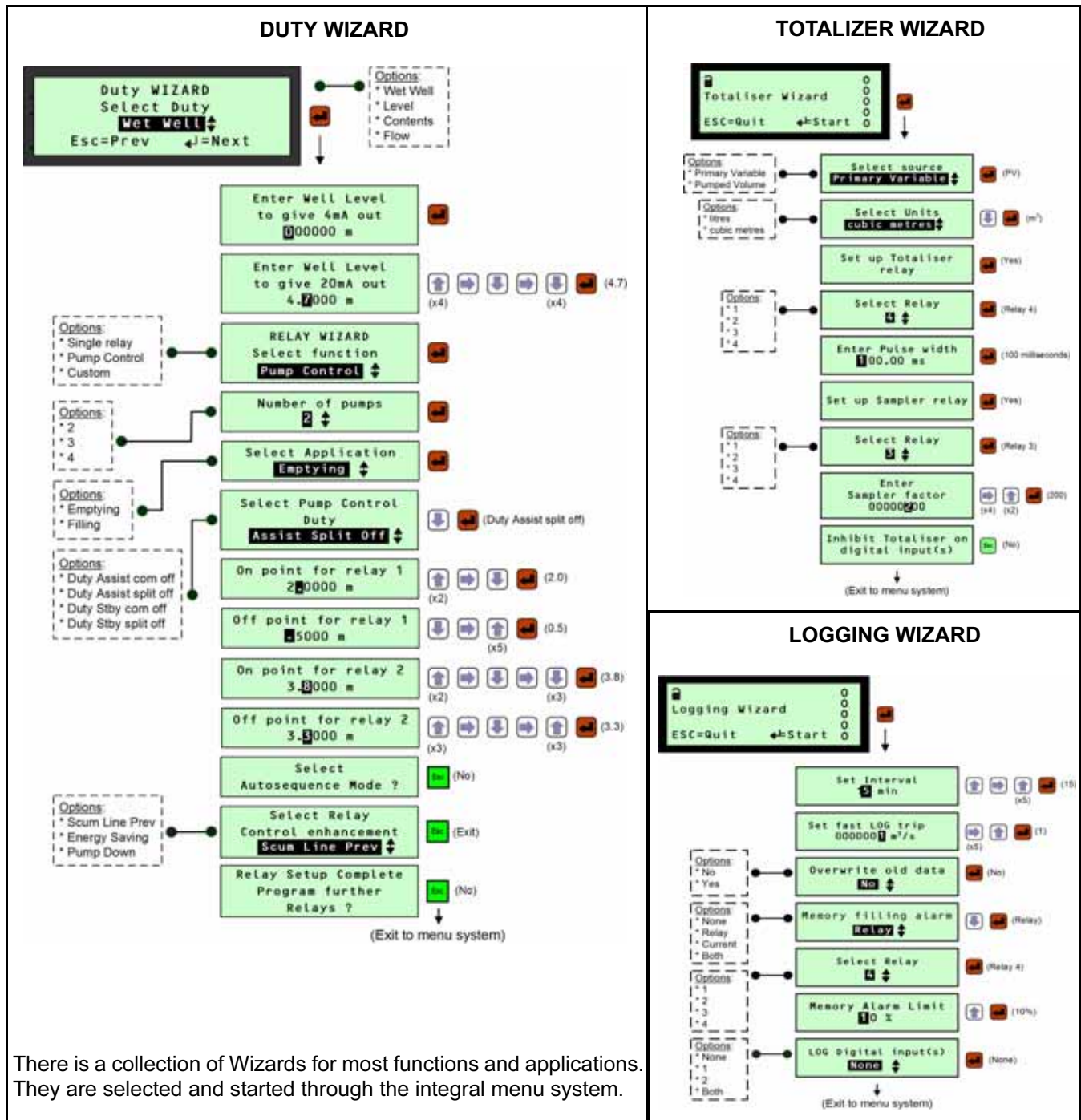

There is a collection of Wizards for most functions and applications. They are selected and started through the integral menu system.

## TECHNICAL SPECIFICATION

<b>General</b>	
Product	Rosemount 3490 Series Universal Control Unit: 3491 - Standard Control Unit 3492 - Differential Control Unit 3493 - Logging Control Unit
Mounting styles	Wall mount or Panel mount
Power options	AC Mains or DC
<b>Display</b>	
Type	Dot matrix LCD, 32 x 122 pixels, back lit
Location	Integrated into enclosure
Indicators	Red LED for health status
<b>Electrical</b>	
AC Mains Power Supply Input	115V or 230V ac $\pm 10\%$ (switch selectable). Power consumption: 10VA nom., 18VA maximum. Fuse: 200mA(T), 5 x 20mm, 250V
DC Power Supply Input	15-30V dc, 30Vdc maximum. Power consumption: 9W maximum.
Current Input	4-20mA (Earth referenced in control unit) or HART digital communications (Rev. 5) Supplies 23 volts from 400 Ohm source resistance.
Trigger Inputs	2 voltage-free contact closures.
Current Output	Signal range (nominal): 4-20mA Output range (linear): 3.8 - 20.5mA. (Alarm current of 3.6mA, 21mA, or 22.5mA - user-selectable) or 3.9 - 20.8mA. (Alarm current of 3.75mA, or 21.75mA - user-selectable) Load: Rmax is 1 K Ohm Resolution: 12-bit Regulation: < 0.1% over load change from 0 to 600 Ohms Isolation: Isolated from other terminals to 500V dc Update rate (software): 5 times per second
Relays	5 SPDT (SPCO), 5A at 240V ac
Cable entry	IP-rated wall mount enclosure: 5 positions pre-drilled, 2 glands and 3 blanking plugs supplied. NEMA4X-rated wall mount enclosure: Positions require drilling by user, glands/conduits and blanking plugs are not supplied. Panel enclosure: Direct wiring to terminal blocks at rear.
Cable connection	Wall mount enclosure: Cage clamp terminal blocks in separate terminal compartment. Panel mount enclosure: 2-part cage clamp terminal blocks at rear.
<b>Mechanical</b>	
Materials of construction (wall mount)	Polycarbonate enclosure and cover. IP-rated wall mount: 304SST cover fixing screws. NEMA4X-rated wall mount: Polyester and monel fastening. UV resistant Polycarbonate membrane keypad. Nylon cable glands and blanking plugs (IP-rated wall mount version only).
Materials of construction (panel mount)	Polycarbonate enclosure and cover. Carbon Steel / Zinc plated fascia fixing screws UV resistant Polycarbonate membrane keypad Nylon + PBT terminal blocks with plated fittings
Dimensions	See Dimensional drawings on page 10, page Accessories-11, and page Accessories-12.

## Product Data Sheet

00813-0100-4841, Rev. AA

Catalog 2008 - 2009

# Rosemount 3490 Series

Weight	IP-rated wall mount: 1.4kg (mains unit) or 1.0kg (DC unit) NEMA4X-rated wall mount: 3.5kg (mains unit) or 3.1kg (DC unit) Panel mount 1.2kg (mains unit) or 0.8kg (DC unit)
<b>Environment</b>	
Ambient temperature	-40 °C to +55 °C (-40 °F to + 131°F) <sup>(1)</sup>
Relative humidity	Wall mount: 100% Panel mount: 90% non-condensing
Electrical safety	EN61010-1
Ingress protection	IP-rated wall mount: IP65 indoor/outdoor. NEMA4X-rated wall mount: NEMA 4X indoor/outdoor. Panel mount: IP40 indoor mount (or IP65 if with optional hood).
Vibration	Control Room: 0.1 - 200Hz, 0.5g acceleration. Field Mounted: 0.1 - 200Hz, 1.0g acceleration, 200 - 2000Hz, 0.5g acceleration.
Installation category	III : Supply voltage < 127Vac - IEC60664 II : Supply voltage < 254Vac - IEC60664
Pollution degree	2 - IEC60664
Maximum altitude	2000 metres
Electromagnetic compatibility	Emissions and Immunity (for IP-rated wall mount and panel mount): IEC 61326:2002 (EN61326:1997+A1+A2+A3).
Certifications	CE-mark, ATEX, IECEx, CSA, or UL - dependent on order code.

(1) See Product certifications on page 13 for approval temperatures ranges.

## DIMENSIONAL DRAWINGS

Figure 4. Dimensions for IP-rated Wall Mount Box

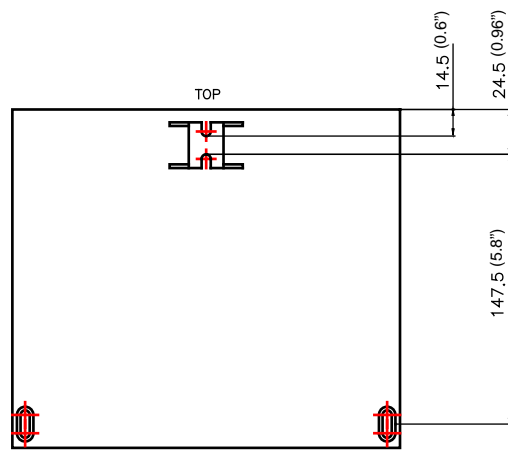
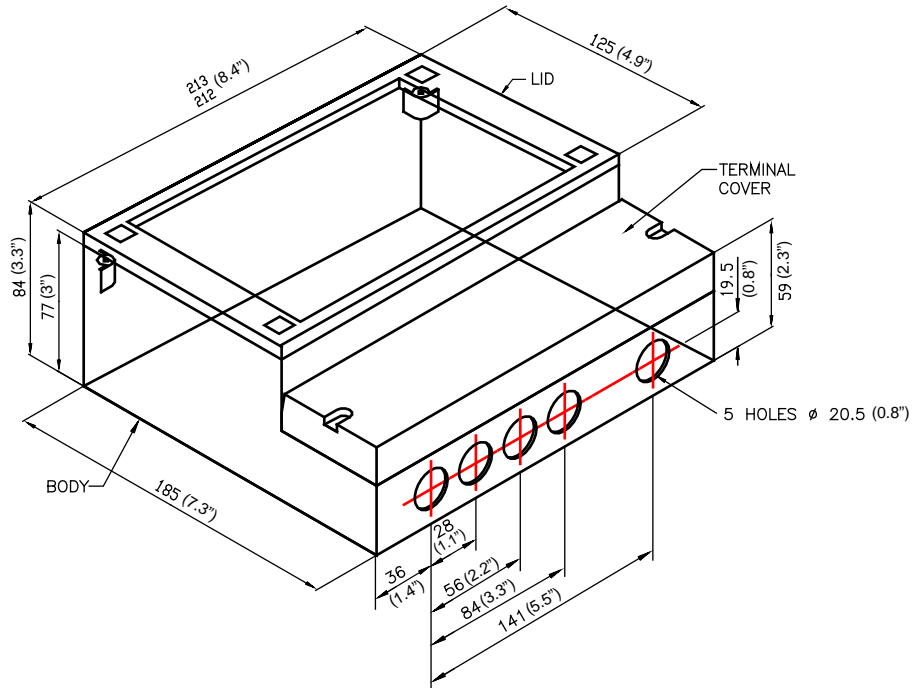

**Product Data Sheet**

00813-0100-4841, Rev. AA  
Catalog 2008 - 2009

# Rosemount 3490 Series

Figure 5.  
Dimensions for NEMA4X-rated Wall Mount Box

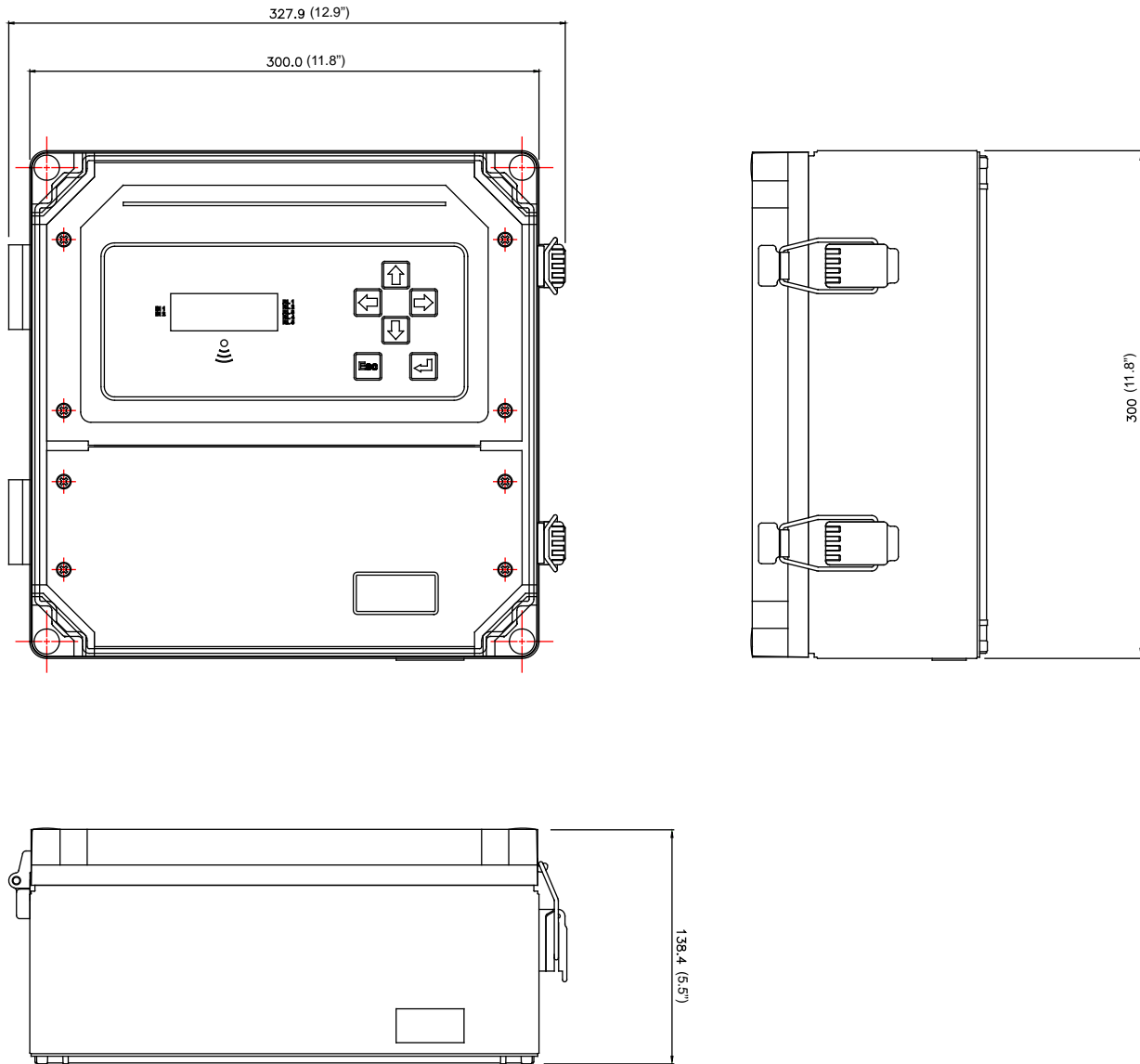

# Rosemount 3490 Series

Figure 6. Dimensions for Panel Mount

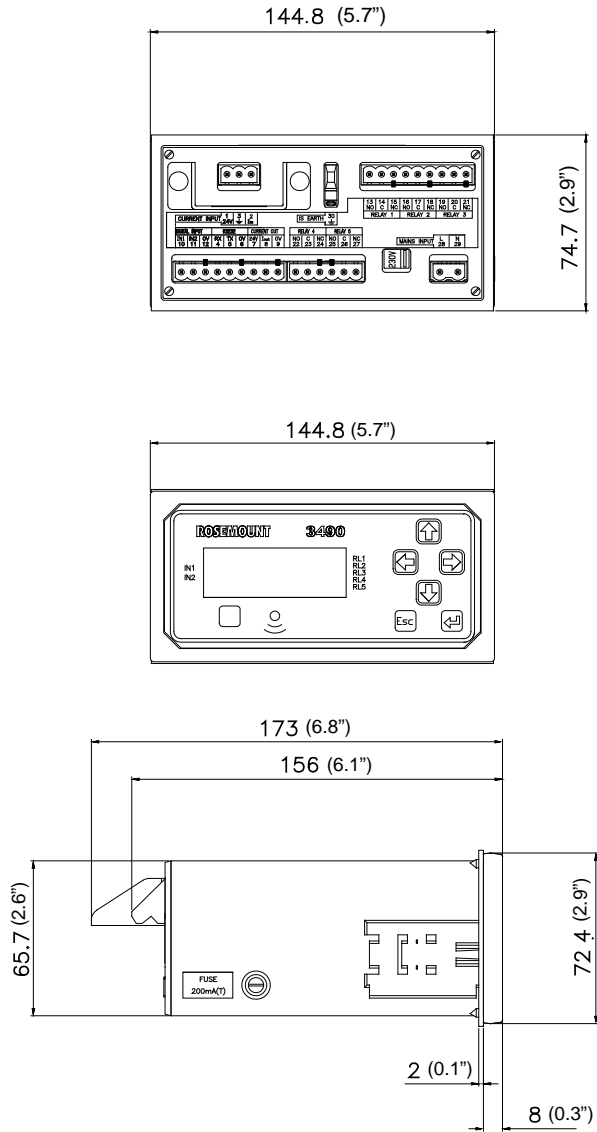

## Product Data Sheet

00813-0100-4841, Rev. AA  
Catalog 2008 - 2009

# Rosemount 3490 Series

## PRODUCT CERTIFICATIONS

### European Directive Information

The EC declaration of conformity for all applicable European directives for this product can be found on the Rosemount website at [www.rosemount.com](http://www.rosemount.com). A hard copy may be obtained by contacting your local sales office.

#### ATEX Directive (94/9/EC)

Complies with the ATEX Directive.

#### Low Voltage Directive (2006/95/EC)

EN61010 Part 1 : 2001

#### Pressure Equipment Directive (PED) (97/23/EC)

Control Unit is outside the scope of PED Directive.

#### Electro Magnetic Compatibility (EMC) Directive

EN61326 (1997) amendments A1, A2, and A3  
(Industrial locations, Class A)

#### CE-mark

Complies with applicable directives:

3401, 3402, and 3403 (EMC, ATEX, LVD)

#### Restriction of Hazardous Substances (ROHS)

3490 Series Control Unit is exempt.

### Hazardous Locations Certifications

#### ATEX Intrinsically Safe Approval

**I1** Certificate Numbers:  
SIRA 06ATEX7128 (Wall Mount),  
SIRA 06ATEX7129X (Panel Mount)  
Intrinsically Safe for II(1) G D, [EEx ia] IIC  
Ambient Temperature: -40°C to +55°C  
U<sub>o</sub> = 27.3 V, I<sub>o</sub> = 96.9 mA, P<sub>o</sub> = 0.66 W,  
L<sub>i</sub> = 0.22 mH, C<sub>i</sub> = 0.6 nF

#### Special conditions for safe use (Certificate SIRA 06ATEX7129X):

1. Terminal 30 must be earthed in the safe area to a high integrity earth .

#### Underwriters Laboratories Inc. (UL) Intrinsically Safe Approval

**I5** Project IDs: E308780, E308781  
Intrinsically Safe for:  
Class I, Division 1, Groups A, B, C, D  
Intrinsically Safe for:  
Class 1, Zone 0, Group IIC  
Ambient Temperature: -40°C to +55°C  
Control Drawing: 71097/1210  
U<sub>o</sub> = 27.3 V, I<sub>o</sub> = 96.9 mA, P<sub>o</sub> = 0.66 W,  
L<sub>a</sub> = 2.26 mH, C<sub>a</sub> = 70 nF

#### Canadian Standards Association (CSA) Intrinsically Safe Approval

**I6** Project ID: 1834150  
Intrinsically Safe for:  
Class I, Division 1, Groups A, B, C, and D  
Intrinsically Safe for:  
Class 1, Zone 0, Group IIC [Ex ia]  
Ambient Temperature: -40°C to +55°C  
Control Drawing: 71097/1201  
U<sub>o</sub> = +27.3 V, I<sub>o</sub> = 96.9 mA, P<sub>o</sub> = 0.66 W,  
L<sub>a</sub> = 2.26 mH, C<sub>a</sub> = 70 nF

#### IECEx Intrinsically Safe Approval

**I7** Certificate Number: IECEx SIR 06.0104X  
Intrinsically Safe for:  
Zone 0, 20, [Ex ia] IIC, [Ex iaD 20]  
Ambient Temperature: -40°C to +55°C  
U<sub>o</sub> = +27.3 V, I<sub>o</sub> = 96.9 mA, P<sub>o</sub> = 0.66 W,  
L<sub>i</sub> = 0.22 mH, C<sub>i</sub> = 0.6 nF

#### Conditions of Certification (Panel Mount):

1. Terminal 30 must be earthed in the safe area to a high integrity earth .

# Rosemount 3490 Series

**Product Data Sheet**  
00813-0100-4841, Rev. AA  
Catalog 2008 - 2009

## **ORDERING INFORMATION**

### **Model Code 3491, Standard Control Unit**

<b>Model</b>	<b>Product Description</b>
3491	Model 3491 Standard Control Unit
<b>Code</b>	<b>Signal Output</b>
L	4-20 mA
<b>Code</b>	<b>Power Supply</b>
1	115/230 Vac
2	24 Vdc
<b>Code</b>	<b>Enclosure / Mounting</b>
P4	Wall mounting, NEMA 4X
P6	Wall mounting, IP65
P7	Panel mounting
<b>Code</b>	<b>Product Certificates</b>
I1	ATEX Intrinsically Safe
I5	UL Intrinsically Safe <sup>(1)</sup> <sup>(2)</sup>
I6	CSA Intrinsically Safe <sup>(3)</sup>
I7	IEC Ex Intrinsically Safe

*(1) Enclosure/Mounting code P4 is required for this option.*

*(2) Power supply code 1 is required for this option.*

*(3) Enclosure/Mounting codes P4 or P7 are required for this option.*

**Example model order code: 3491-L-1-P4-I5**

## Product Data Sheet

00813-0100-4841, Rev. AA

Catalog 2008 - 2009

## Rosemount 3490 Series

### Model Code 3492, Differential Control Unit

Model	Product Description
3492	Model 3492 Differential Control Unit
Code	Signal Output
L	4-20 mA
Code	Power Supply
1	115/230 Vac
2	24 Vdc
Code	Enclosure / Mounting
P4	Wall mounting, NEMA 4X
P6	Wall mounting, IP65
P7	Panel mounting
Code	Product Certificates
I1	ATEX Intrinsically Safe
I5	UL Intrinsically Safe <sup>(1)</sup> <sup>(2)</sup>
I6	CSA Intrinsically Safe <sup>(3)</sup>
I7	IEC Ex Intrinsically Safe

*(1) Enclosure/Mounting code P4 is required for this option.*

*(2) Power supply code 1 is required for this option.*

*(3) Enclosure/Mounting codes P4 or P7 are required for this option.*

**Example model order code: 3492-L-1-P4-I5**

# Rosemount 3490 Series

**Product Data Sheet**  
00813-0100-4841, Rev. AA  
Catalog 2008 - 2009

## Model Code 3493, Logging Control Unit

Model	Product Description
3493	Model 3493 Logging Control Unit
Code	Signal Output
L	4-20 mA
Code	Power Supply
1	115/230 Vac
2	24 Vdc
Code	Enclosure / Mounting
P4	Wall mounting, NEMA 4X
P6	Wall mounting, IP65
P7	Panel mounting
Code	Product Certificates
I1	ATEX Intrinsically Safe
I5	UL Intrinsically Safe <sup>(1)</sup> <sup>(2)</sup>
I6	CSA Intrinsically Safe <sup>(3)</sup>
I7	IEC Ex Intrinsically Safe

*(1) Enclosure/Mounting code P4 is required for this option.*

*(2) Power supply code 1 is required for this option.*

*(3) Enclosure/Mounting codes P4 or P7 are required for this option.*

**Example model order code: 3493-L-1-P4-I5**



*Standard Terms and Conditions of Sale can be found at [www.rosemount.com/terms\\_of\\_sale](http://www.rosemount.com/terms_of_sale)  
The Emerson logo is a trademark and service mark of Emerson Electric Co.  
Rosemount and the Rosemount logotype are registered trademarks of Rosemount Inc.  
All other marks are the property of their respective owners.*

**Emerson Process Management, Rosemount Inc.**

**Rosemount Inc.**  
8200 Market Boulevard  
Chanhassen, MN 55317 USA  
T (U.S.) 1 800 999 9307  
T (International) (952) 906 8888  
F (952) 949 7001

**Emerson Process Management**  
Heath Place  
Bognor Regis  
West Sussex PO22 9SH  
England  
Tel 44 (1243) 863 121  
Fax 44 (1243) 867 5541

**Emerson Process Management  
Asia Pacific Private Limited**  
1 Pandan Crescent  
Singapore 128461  
T (65) 777 8211  
F (65) 777 0947  
Enquiries@AP.EmersonProcess.com

[www.rosemount.com](http://www.rosemount.com)