

# Rosemount 148 Temperature Transmitter

- *Basic temperature transmitter offers a cost-effective solution for temperature monitoring points*
- *Standard transmitter design provides flexible and reliable performance in process environments*
- *Experience lower overall installation costs when compared to wiring sensor directly, reducing the need for expensive extension wires and multiplexers*
- *PC-based HART configuration interface delivers a programmer, cables, and the software needed for transmitter configuration*
- *Explore the benefits of a Complete Point Solution from Rosemount Temperature*



## Content

Rosemount 148 Temperature Transmitter . . . . .	page 2
Ordering Information . . . . .	page 3
Transmitter Specifications . . . . .	page 6
Product Certifications . . . . .	page 8
Dimensional Drawings . . . . .	page 10

## Rosemount 148

# Rosemount 148 Temperature Transmitter

### Basic temperature transmitter offers a cost-effective solution for temperature monitoring points

- DIN B style head mount transmitter
- Variety of DIN B enclosure options
- 4-20 mA analog protocol
- Single sensor capability with universal sensor inputs (RTD, T/C, ohms)
- PC-based configuration

### Standard transmitter design provides flexible and reliable performance in process environments

- Offers improved measurement accuracy and reliability over direct-wiring a sensor to the digital control system for a lower overall installation cost
- One-year stability rating reduces maintenance costs
- PC-based configuration interface delivers a programmer, cables, and the software needed for transmitter configuration
- Compensation for ambient temperature enhances transmitter performance

### Explore the benefits of a Complete Point Solution from Rosemount Temperature Measurement

- An “Assemble To Sensor” option enables Emerson to provide a complete point temperature solution, delivering an installation-ready transmitter and sensor assembly
- Emerson offers a selection of RTDs, thermocouples, and thermowells that bring superior durability and Rosemount reliability to temperature sensing, complementing the Rosemount Transmitter portfolio



### Experience global consistency and local support from numerous worldwide Rosemount Temperature manufacturing sites



- World-class manufacturing provides globally consistent product from every factory and the capacity to fulfill the needs of any project, large or small
- Experienced Instrumentation Consultants help select the right product for any temperature application and advise on best installation practices
- An extensive global network of Emerson service and support personnel can be on-site when and where they are needed

- 
- Looking to measure more temperature points in a cost effective way? Consider a wireless temperature solution. The Rosemount 248 Wireless temperature transmitter is solid performing, yet economical.
  - For temperature installations that require reliable measurement and can benefit from HART functionality, the Rosemount 248 temperature transmitter is a cost-effective solution.
-

## Rosemount 148 Temperature Transmitter



The Rosemount 148 temperature transmitter has a standard transmitter design that provides reliable performance in process environments.

Transmitter features include:

- 4-20 mA Analog Output
- Variety of DIN B enclosure options
- 3-Point Calibration Certificate (Option Code Q4)
- Assemble to Sensor options (Option Code XA)

Table 1. Rosemount 148 PC-Programmable Temperature Transmitter Ordering Information

★ The Standard offering represents the most common options. The starred options (★) should be selected for best delivery. The Expanded offering is subject to additional delivery lead time.

Model	Product Description			
148	PC Programmable Temperature Transmitter			
<b>Transmitter Type</b>				
<b>Standard</b>				
H	DIN B Head Mount			★
<b>Transmitter Output</b>				
<b>Standard</b>				
N	Analog Output			★
<b>Product Certifications</b>				
<b>Standard</b>				
I5	FM Intrinsic Safety and Class 1, Division 2			★
E5 <sup>(1)</sup>	FM Explosion-Proof			★
K5 <sup>(1)</sup>	FM Intrinsic Safety, Explosion-Proof, and Class 1, Division 2			★
I6	CSA Intrinsic Safety and Class 1, Division 2			★
K6 <sup>(1)</sup>	CSA Intrinsic Safety, Explosion-Proof, and Class 1, Division 2			★
I1	ATEX Intrinsic Safety			★
E1 <sup>(1)</sup>	ATEX Flameproof			★
N1 <sup>(1)</sup>	ATEX Type n			★
NC	ATEX Type n Component			★
ND <sup>(1)</sup>	ATEX Dust Ignition-Proof			★
I7	IECEX Intrinsic Safety			★
E7 <sup>(1)</sup>	IECEX Flameproof and Dust			★
N7 <sup>(1)</sup>	IECEX Type n			★
NG	IECEX Type n Component			★
NA	No approvals			★
<b>Enclosure Options</b>		<b>Material</b>	<b>IP Rating</b>	
<b>Standard</b>				
A	Connection Head	Aluminum	IP68	★
U	Universal Head (Junction Box)	Aluminum	IP68	★

# Rosemount 148

Table 1. Rosemount 148 PC-Programmable Temperature Transmitter Ordering Information

★ The Standard offering represents the most common options. The starred options (★) should be selected for best delivery.  
The Expanded offering is subject to additional delivery lead time.

B	BUZ Head	Aluminum	IP65	★
C	BUZ Head	Polypropylene	IP65	★
N	No Enclosure			★
<b>Expanded</b>				
G	Connection Head	SST	IP68	
H	Universal Head (Junction Box)	SST	IP68	
S	Sanitary Connection Head, DIN B	Polished SST	IP66	
F	Sanitary Connection Head, DIN A	Polished SST	IP66/IP68	
<b>Conduit Entry Size</b>				
<b>Standard</b>				<b>Standard</b>
1	M20 x 1.5 (CM20)			★
2	1/2-14 in. NPT			★
0	No Enclosure			★

## Options (Include with selected model number)

<b>Alarm Level Configuration</b>				
<b>Standard</b>				<b>Standard</b>
A1	NAMUR alarm and saturation levels, high alarm			★
CN	NAMUR alarm and saturation levels, low alarm			★
<b>Calibration Certificate</b>				
<b>Standard</b>				<b>Standard</b>
Q4	Calibration Certificate (3-point Calibration)			★
<b>Line Filter</b>				
<b>Standard</b>				<b>Standard</b>
F6	60 Hz Line Voltage Filter			★
<b>External Ground Option (Available w/Enclosures U, H)</b>				
<b>Standard</b>				<b>Standard</b>
G1	External Ground Lug Assembly			★
<b>Cover Chain Option (Available w/Enclosures U, H)</b>				
<b>Standard</b>				<b>Standard</b>
G3	Cover Chain			★
<b>Cable Gland Option</b>				
<b>Standard</b>				<b>Standard</b>
G2	Cable Gland–Explosion Proof–7.5 mm - 11.9 mm			★
G4	Cable Gland–Explosion Proof, Thin Wire - 3.0 mm - 8.0 mm			★
<b>Conduit Electrical Connector</b>				
<b>Standard</b>				<b>Standard</b>
GE	M12, 4-pin, Male Connector (eurofast®)			★
GM	A size Mini, 4-pin, Male Connector (minifast®)			★
<b>Assemble To Options</b>				
<b>Standard</b>				<b>Standard</b>
XA	Sensor Specified Separately and Assembled to Transmitter			★
<b>Typical Model Number: 148 H N I5 U1 A1 XA</b>				

(1) Approval Codes E1, N1, N7, ND, E5, K5, K6, and E7 require an enclosure

# Product Data Sheet

00813-0100-4148, Rev EA

April 2011

# Rosemount 148

## Rosemount 148 PC Programmer

The Rosemount 148 PC Programmer is a portable, self-contained communication link between your PC and the 148 transmitter for use in non-hazardous environments. The 148 PC Programmer contains the following items:

- PC Programmer Unit
- Programming Software (CD-ROM)
- 9V Battery
- Transmitter Connectors

## Rosemount 148 PC Programmer Software

The software makes the following parameters available:

- Process Variable
- Sensor Type
- Number of Wires
- Engineering Units
- Transmitter Tag Information
- Damping
- Alarming Parameters

To order the 148 PC Programmer, use Part Number 00148-1601-0001.

**Table 2. Rosemount 148 Transmitter Accessories**

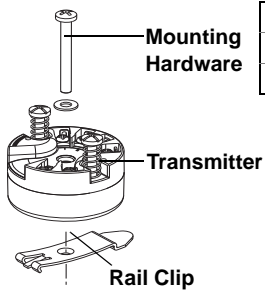

External Ground Screw Assembly Kit	00644-4431-0001
Kit, Hardware for Mounting a 148 to a DIN Rail (see left picture-top hat rail, symmetric)	00248-1601-0001
Snap Rings Kit (used for assembly to DIN Plate Style sensor)	00644-4432-0001

## Transmitter Specifications

### FUNCTIONAL SPECIFICATIONS

#### Inputs

User-selectable; sensor terminals rates to 42.4 Vdc. See "Transmitter Accuracy and Ambient Temperature Effects" on page 7 for sensor options.

#### Output

2-wire 4–20 mA, linear with temperature or input.

#### Isolation

Input/Output isolation tested to 500 Vac rms (707 Vdc) at 50/60 Hz.

#### Supply Voltage DC

Standard: 12 to 35 V  
Intrinsic Safety: 12 to 28 V

#### Minimum Voltage Across Terminals

12 Vdc

#### Humidity Limits

0 - 95% relative humidity, non-condensing

#### NAMUR Recommendations

The 148 meets the following NAMUR recommendations:

- NE 21 - Electromagnetic compatibility (EMC) for Process and Laboratory Apparatus
- NE 43 - Standard of the signal level breakdown information of digital transmitters

#### Transient Protection

The optional Rosemount 470 Transient Protector prevents damage from transients induced by lightning, welding, heavy electrical equipment, or switch gears. Refer to the 470 Product Data Sheet (document number 00813-0100-4191) for more information.

#### Temperature Limits

- Operating Limit
- -40 to 185 °F (-40 to 85 °C)
- Storage Limit
- -58 to 248 °F (-50 to 120 °C)

#### Turn-on Time

Performance within specifications is less than 5.0 seconds after power is applied to the transmitter, when damping value is set to zero seconds.

#### Update Rate

Less than 0.5 seconds

#### Damping

32 seconds maximum, 5 seconds default.

#### Recommended Minimum Measuring Span

18 °F (10 °C)

### Software Detected Failure Mode

The values at which the transmitter drives its output in failure mode depends on device configuration. The device can be configured to meet NAMUR-compliant (NAMUR recommendation NE 43) operation. The values for standard and NAMUR-compliant operation are as follows:

Table 3. Operation Parameters

	Standard <sup>(1)</sup>	NAMUR NE43-Compliant <sup>(1)</sup>
Linear Output:	$3.9 \leq I \leq 20.5$	$3.8 \leq I \leq 20.5$
Fail High:	$21 \leq I \leq 23$ (default)	$21 \leq I \leq 23$ (default)
Fail Low:	$I \leq 3.75$	$I \leq 3.6$

<sup>(1)</sup> Measured in milliamperes

Certain hardware failures, such as microprocessor failures, will always drive the output to greater than 23 mA.

### PERFORMANCE SPECIFICATIONS

#### EMC (ElectroMagnetic Compatibility) NAMUR NE21 Standard

The 148 meets the requirements for NAMUR NE21 Rating

Susceptibility	Parameter	Influence
ESD	<ul style="list-style-type: none"> <li>• 6 kV contact discharge</li> <li>• 8 kV air discharge</li> </ul>	None
Radiated	<ul style="list-style-type: none"> <li>• 80 – 1000 MHz at 10 V/m AM</li> </ul>	None
Burst	<ul style="list-style-type: none"> <li>• 1 kV for I.O.</li> </ul>	None
Surge	<ul style="list-style-type: none"> <li>• 0.5 kV line–line</li> <li>• 1 kV line–ground (I.O. tool)</li> </ul>	None
Conducted	<ul style="list-style-type: none"> <li>• 150 kHz to 80 MHz at 10 V</li> </ul>	None

#### CE Mark

The 148 meets all of the requirements listed under IEC 61326: Amendment 1, 2006.

#### Power Supply Effect

Less than ±0.0055 of span per volt.

#### Vibration Effect

The 148 is tested to the following specifications with no effect on performance:

Frequency	Vibration
10 to 60 Hz	0.21 mm displacement
60 to 2000 Hz	3 g peak acceleration

#### Stability

For RTD and thermocouple inputs, the transmitter will have a stability of ±0.15% of reading or 0.15 °C (whichever is greater) for twelve months.

**Sensor Connections**

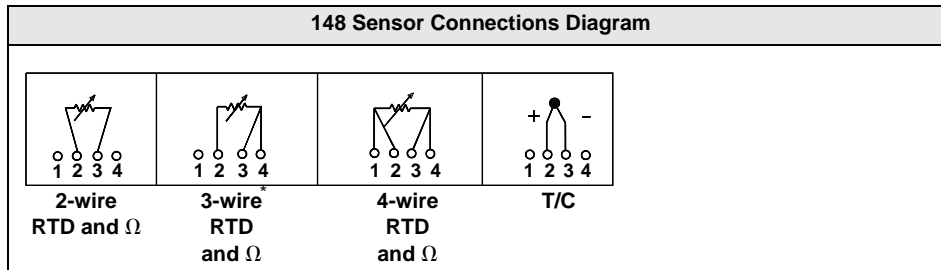

\* Rosemount Inc. provides 4-wire sensors for all single element RTDs. You can use these RTDs in 3-wire configurations by leaving the unneeded leads disconnected and insulated with electrical tape.

**Transmitter Accuracy and Ambient Temperature Effects**

**NOTE**

The accuracy and ambient temperature effect is the greater of the fixed and percent of span values (see example below).

Table 4. 148 Transmitter Input Options, Accuracy, and Ambient Temperature Effects

Sensor	Transmitter Input Ranges <sup>(1)</sup>		Accuracy		Temperature Effects per 1.0 °C (1.8 °F) Change in Ambient Temperature <sup>(2)</sup>	
	°C	°F	Fixed	% of Span	Fixed	% of Span
2-, 3-, 4-wire RTDs						
Pt 100 <sup>(3)</sup> (α = 0.00385)	-200 to 850	-328 to 1562	0.3 °C (0.54 °F)	±0.15	0.009 °C (0.016 °F)	±0.006
Pt 100 <sup>(4)</sup> (α = 0.003916)	-200 to 645	-328 to 1193	0.3 °C (0.54 °F)	±0.15	0.009 °C (0.016 °F)	±0.006
Ni 120 <sup>(5)</sup>	-70 to 300	-94 to 572	0.2 °C (0.36 °F)	±0.15	0.006 °C (0.011 °F)	±0.006
Cu 10 <sup>(6)</sup>	-50 to 250	-58 to 482	3 °C (5.40 °F)	±0.15	0.09 °C (0.16 °F)	±0.006
Thermocouples <sup>(7)</sup>						
Type B <sup>(8)</sup> <sup>(9)</sup>	100 to 1820	212 to 3308	2.3 °C (4.05 °F)	±0.15	0.084 °C (0.150 °F)	±0.006
Type J <sup>(8)</sup>	-180 to 760	-292 to 1400	0.8 °C (1.35 °F)	±0.15	0.03 °C (0.054 °F)	±0.006
Type K <sup>(8)</sup> <sup>(10)</sup>	-180 to 1372	-292 to 2502	0.8 °C (1.35 °F)	±0.15	0.03 °C (0.054 °F)	±0.006
Type N <sup>(8)</sup>	-200 to 1300	-328 to 2372	1.2 °C (2.16 °F)	±0.15	0.03 °C (0.054 °F)	±0.006
Type R <sup>(8)</sup>	0 to 1768	32 to 3214	1.8 °C (3.24 °F)	±0.15	0.09 °C (0.16 °F)	±0.006
Type S <sup>(8)</sup>	0 to 1768	32 to 3214	1.5 °C (2.70 °F)	±0.15	0.09 °C (0.16 °F)	±0.006
2-, 3-, 4-wire Ohm Input	0 to 2000 ohms		1.1 ohm	±0.15	0.042 ohm	±0.009

(1) Input ranges are for transmitter only. Actual sensor (RTD or Thermocouple) operating ranges may be more limited.

(2) Change in ambient is with reference to the calibration temperature of the transmitter at 68 °F (20 °C) from factory.

(3) IEC 751, 1995.

(4) JIS 1604, 1981.

(5) Edison Curve No. 7.

(6) Edison Copper Winding No. 15.

(7) Total accuracy for thermocouple measurement: sum of accuracy +0.5 °C.

(8) NIST Monograph 175, IEC 584.

(9) Fixed accuracy for NIST Type B is ±5.4 °F (±3.0 °C) from 212 to 572 °F (100 to 300 °C).

(10) Fixed accuracy for NIST Type K is ±1.3 °F (±0.7 °C) from -292 to -130 °F (-130 to -90 °C).

**Transmitter Accuracy Example**

When using a Pt 100 (a = 0.00385) sensor input with a 0 to 100 °C span, use the greater of the two calculated values. In this case, the accuracy would be +/-0.3 °C.

**Transmitter Temperature Effects Example**

Transmitters can be installed in locations where the ambient temperature is between -40 and 85 °C (-40 and 185 °F). In order to maintain excellent accuracy performance, each transmitter is individually characterized over this ambient temperature range at the factory.

When using a Pt 100 (a = 0.00385) sensor input with a 0-100 °C span at 30 °C ambient temperature:

- Temperature Effects: 0.009 °C x (30 - 20) = 0.09 °C

**Total Transmitter Error**

Worst Case Transmitter Error: Accuracy + Temperature Effects = 0.3 °C + 0.09 °C = 0.39 °C

Total Probable Transmitter Error:  $\sqrt{0.3^2 + 0.09^2} = 0.31 °C$

## Product Certifications

### APPROVED MANUFACTURING LOCATIONS

Rosemount Inc. – Chanhassen, Minnesota, USA  
Emerson Process Management Temperature GmbH – Karlstein, Germany  
Emerson Process Management Asia Pacific – Singapore

### EUROPEAN UNION DIRECTIVE INFORMATION

The EC declaration of conformity for all applicable European directives for this product can be found on the Rosemount website at [www.rosemount.com](http://www.rosemount.com). A hard copy may be obtained by contacting your local sales representative.

#### ATEX Directive (94/9/EC)

Rosemount Inc. complies with the ATEX Directive.

#### Electro Magnetic Compatibility (EMC) (89/336/EEC)

All Models: EN 50081-1: 1992; EN 50082-2: 1995; EN 61326-1: 2006

#### CE Mark

The 148 meets all requirements listed under IEC 61326:Amendment 1, 2006

### HAZARDOUS LOCATIONS CERTIFICATIONS<sup>(1)</sup>

#### North American Certifications

##### Factory Mutual (FM)

- I5 FM Intrinsic Safety and Non-incendive Intrinsically Safe for Class I/II/III, Division 1, Groups A, B, C, D, E, F, and G. Non-incendive Field Circuit for Class I, Division 2, Groups A, B, C, and D. Intrinsically Safe and non-incendive when installed in accordance with Rosemount drawing 00148-1055.

Temperature Codes:

T5 ( $T_{amb} = -50$  to  $75$  °C)

T6 ( $T_{amb} = -50$  to  $40$  °C)

Table 5. Entity Parameters

Loop/Power	Sensor
$U_i = 30$ Vdc	$U_o = 45$ Vdc
$I_i = 130$ mA	$I_o = 26$ mA
$P_i = 1.0$ W	$P_o = 290$ mW
$C_i = 3.6$ nF	$C_o = 0.4$ nF
$L_i = 13.8$ μH	$L_o = 49.2$ mH

- E5 FM Explosion-Proof Explosion-Proof for Class I, Division 1, Groups B, C, and D. Dust Ignition Proof for Class II/III, Division 1, Groups E, F, G when installed in accordance with Rosemount drawing 00148-1065.

Temperature Code:

T5 ( $T_{amb} = -40$  to  $85$  °C)

#### Combination Certifications

- K5 Combination of I5 and E5.

#### Canadian Standards Association (CSA) Approvals

- I6 CSA Intrinsically Safe and Class I, Division 2 Intrinsically Safe for Class I, Division 1, Groups A, B, C, and D when installed in accordance with Rosemount drawing 00148-1056.

Temperature Codes:

T5 ( $T_{amb} = -50$  to  $60$  °C)

T6 ( $T_{amb} = -50$  to  $40$  °C)

Suitable for use in Class I, Division 2, Groups A, B, C, and D.

- K6 CSA Intrinsically Safe, Explosion-Proof, and Class I, Division 2. Combination of I6 and Explosion-Proof for Class I, Division 1, Groups B, C, and D; Class II, Division 1, Groups E, F, and G; Class III, Division 1 hazardous locations, when installed in accordance with Rosemount drawing 00644-1059.

Suitable for Class I, Division 2, Groups A, B, C, and D.

Ambient Temperature Limit:  $-50$  to  $85$  °C

#### European Certifications

- I1 ATEX Intrinsic Safety  
Certificate Number: Baseefa080ATEX0030X  
ATEX Marking: Ⓔ II 1 G  
**CE** 1180  
Ex ia IIC  
Temperature Codes:  
T5 ( $-60 \leq T_{amb} \leq 80$  °C)  
T6 ( $-60 \leq T_{amb} \leq 60$  °C)

Table 6. Entity Parameters

Loop/Power	Sensor
$U_i = 30$ Vdc	$U_o = 45$ Vdc
$I_i = 130$ mA	$I_o = 26$ mA
$P_i = 1.0$ W	$P_o = 290$ mW
$C_i = 3.6$ nF	$C_i = 2.1$ nF
$L_i = 0$	$L_i = 0$

#### Special Conditions for Safe Use (X):

The apparatus must be installed in an enclosure which affords it a degree of protection of at least IP20.

Non-metallic enclosures must have a surface resistance of less than 1 GOHM; light alloy or zirconium enclosures must be protected from impact and friction when installed.

(1) Consult factory for availability.

# Product Data Sheet

00813-0100-4148, Rev EA

April 2011

# Rosemount 148

- E1 ATEX Flame-Proof  
 Certificate Number: KEMA99ATEX8715X  
 ATEX Marking: Ⓔ II 2 G  
**CE** 1180  
 Ex d IIC  
 Table 7. Input Parameters

$U_{max} = 42.4 \text{ Vdc}$
$I_{max} = 24 \text{ mA}$

Temperature Codes:  
 T6 ( $-50 \leq T_{amb} \leq 65 \text{ }^\circ\text{C}$ )

### Special Conditions for Safe Use (X):

For information on the dimensions of the flameproof joints the manufacturer shall be contacted.

- N1 ATEX Type n  
 Certificate Number: BAS00ATEX3145  
 ATEX Marking: Ⓔ II 3  
 Ex nL IIC  
 Table 8. Input Parameters

$U_{max} = 45 \text{ V}$
--------------------------

Temperature Codes:  
 T5 ( $-40 \leq T_{amb} \leq 70 \text{ }^\circ\text{C}$ )

- NC ATEX Type n Component  
 Certificate Number: Baseefa08ATEX0031U  
 ATEX Marking: Ⓔ II 3G  
 Ex nA IIC  
 Table 9. Input Parameters

$U_i = 42.4 \text{ V}$
$C_i = 3.6 \text{ nF}$
$L_i = 0$

Temperature Codes:  
 T5 ( $-60 \leq T_{amb} \leq 80 \text{ }^\circ\text{C}$ )  
 T6 ( $-60 \leq T_{amb} \leq 60 \text{ }^\circ\text{C}$ )

- ND ATEX Dust Ignition Proof  
 Certificate Number: KEMA99ATEX8715X  
 ATEX Marking: II 1 D  
 CE 1180  
 T95 C ( $-40 \leq T_{amb} \leq 85 \text{ }^\circ\text{C}$ )  
 IP66

### Special Conditions for Safe Use (X):

For information on the dimensions of the flameproof joints the manufacturer shall be contacted.

Table 10. Input Parameters

$U_{max} = 42.4 \text{ Vdc}$
$I_{max} = 24 \text{ mA}$

### Brazilian Certifications

Centro de Pesquisas de Energia Eletrica  
 (CEPEL) Approval

- I2 CEPEL Intrinsic Safety

### IECEX Certifications

- E7 IECEX Flameproof and Dust  
 Certificate Number: IECEX KEM 09.0015X  
 Ex d IIC T6 (Flameproof)  
 Ex tD A20 IP 66 T 95 °C (Dust)  
 $V_{max} = 42.4 \text{ V}$

### Special Conditions for Safe Use (X):

For information on the dimensions of the flameproof joints the manufacturer shall be contacted.

Table 11. Electrical Data

Transmitter	Sensor
$U_{max} = 42.4 \text{ Vdc}$	$U_{max} = 5 \text{ V}$
$I_{max} = 24.0 \text{ mA}$	$I_{max} = 2.0 \text{ mA}$

- I7 IECEX Intrinsic Safety  
 Certificate Number: IECEX BAS 08.0011X  
 Ex ia IIC T5 ( $-60 \text{ }^\circ\text{C} \leq T_{amb} \leq 80 \text{ }^\circ\text{C}$ )  
 Ex ia IIC T6 ( $-60 \text{ }^\circ\text{C} \leq T_{amb} \leq 60 \text{ }^\circ\text{C}$ )

### Special Conditions for Safe Use (X):

The apparatus must be installed in an enclosure which affords it a degree of protection of at least IP20. Non-metallic enclosures must have a surface resistance of less than 1 GΩ; light alloy or zirconium enclosures must be protected from impact and friction when installed.

Table 12. Entity Parameters

Transmitter	Sensor
$U_i = 30 \text{ Vdc}$	$U_o = 45 \text{ Vdc}$
$I_i = 130 \text{ mA}$	$I_o = 26 \text{ mA}$
$P_i = 1.0 \text{ W}$	$P_o = 290 \text{ mW}$
$C_i = 3.63 \text{ nF}$	$C_i = 2.1 \text{ nF}$
$L_i = 0 \text{ mH}$	$L_i = 0 \text{ mH}$

- N7 IECEX Type n  
 Certificate Number: IECEX BAS 07.0055  
 Ex nA nL IIC T5 ( $-40 \text{ }^\circ\text{C} \leq T_{amb} \leq 70 \text{ }^\circ\text{C}$ )

Table 13. Electrical Data

Transmitter	Sensor	
	RTD	Thermocouple
$U_i = 45 \text{ V}$	$U_i = 5 \text{ V}$	$U_i = 0$

- NG IECEX Type n Component  
 Certificate number: IECEX BAS08.0012U  
 Ex nA IIC T5 ( $-60 \text{ }^\circ\text{C} \leq T_{amb} \leq 80 \text{ }^\circ\text{C}$ )  
 Ex nA IIC T6 ( $-60 \text{ }^\circ\text{C} \leq T_{amb} \leq 60 \text{ }^\circ\text{C}$ )  
 Input Parameter:  $U_i = 42.4 \text{ Vdc}$

### Schedule of Limitations:

The component must be housed in a suitably certified enclosure that provides a degree of protection of at least IP54.

## Dimensional Drawings

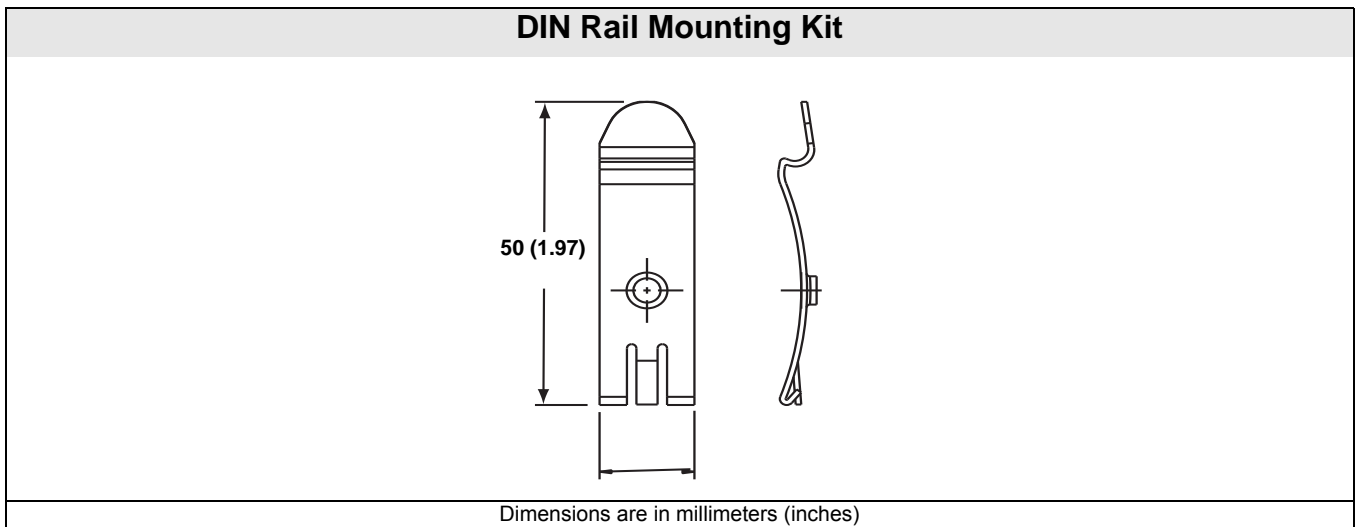
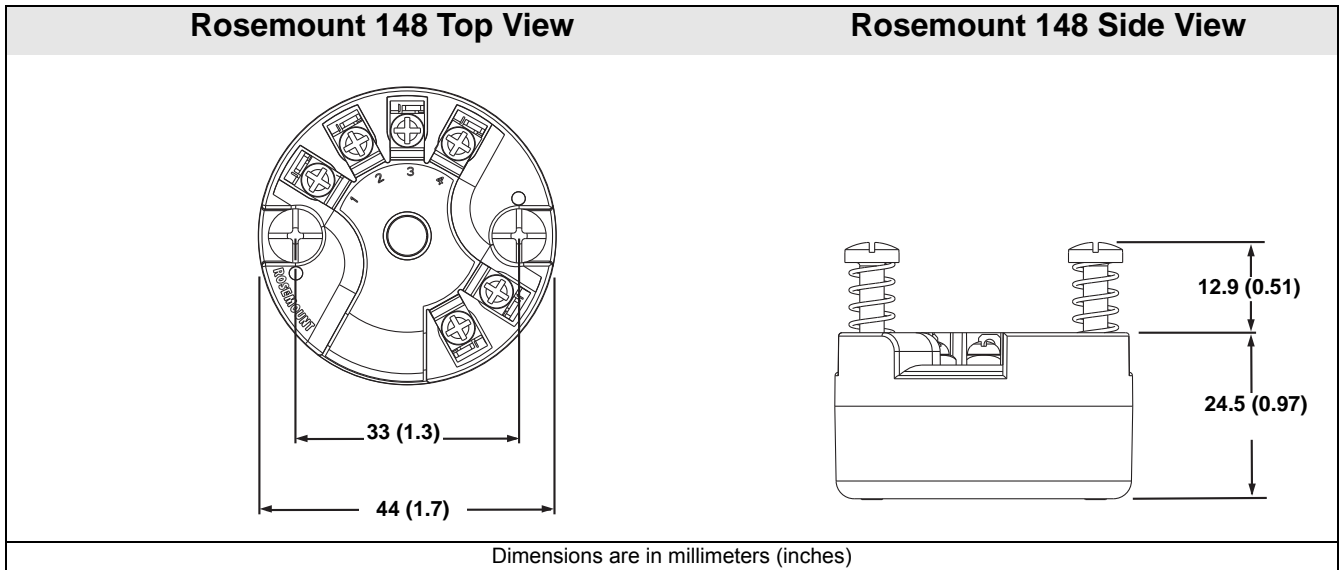

*The Emerson logo is a trademark and service mark of Emerson Electric Co.  
Rosemount and the Rosemount logotype are registered trademarks of Rosemount Inc.  
PlantWeb is a registered trademark of one of the Emerson Process Management group of companies.  
Eurofast and Minifast are registered trademarks of Turck Inc.  
All other marks are the property of their respective owners.  
Standard Terms and Conditions of Sale can be found at [www.rosemount.com/terms\\_of\\_sale](http://www.rosemount.com/terms_of_sale)  
© 2011 Rosemount Inc. All rights reserved*

**Emerson Process Management  
Rosemount Inc.**  
8200 Market Boulevard  
Chanhassen, MN 55317 USA  
T (U.S.) 1-800-999-9307  
T (International) (952) 906-8888  
F (952) 949-7001

**Emerson Process Management**  
Blegistrasse 23  
P.O. Box 1046  
CH 6341 Baar  
Switzerland  
T +41 (0) 41 768 6111  
F +41 (0) 41 768 6300

**Emerson FZE**  
P.O. Box 17033  
Jebel Ali Free Zone  
Dubai UAE  
T +971 4 883 5235  
F +971 4 883 5312

**Emerson Process ManagementAsia  
Pacific Pte Ltd**  
1 Pandan Crescent  
Singapore 128461  
T +65 6777 8211  
F +65 6777 0947  
Service Support Hotline: +65 6770 8711  
Email: [Enquiries@AP.EmersonProcess.com](mailto:Enquiries@AP.EmersonProcess.com)

[www.rosemount.com](http://www.rosemount.com)