

3420 Fieldbus Interface Module (FIM)

- *Obtain all the benefits of FOUNDATION™ fieldbus technology and products without a fieldbus ready system*
- *Interface to existing systems with Modbus®, OPC, XML, and HTTP protocols*
- *Integrated webserver for access to field device and process data*
- *Ethernet and RS485 serial communications for easy integration in industrial applications*



Contents

Specifications	page 5
Product Certifications	page 7
Dimensional Drawings	page 8
Ordering Information	page 9

3420 Fieldbus Interface Module (FIM)

The 3420 Opens up Fieldbus Devices for use in ANY Plant

The 3420 enables the full capability of fieldbus technology and products. Standard Ethernet and RS485 serial communications provide connectivity to systems without fieldbus capability either hard wired or wireless through Industrial WiFi equipment. Host protocols such as Modbus and OPC allow data to be exchanged between the 3420 and other host applications. A built-in web browser provides full support for configuration of connected field devices as well as monitoring process variables and status.

Supports 4 FOUNDATION™ fieldbus H1 Segments

The 3420 interfaces with up to four FOUNDATION fieldbus H1 segments providing connection to as many as 64 field devices. 24 V dc power brought to the 3420 may also be used to power the 2-wire devices on the segments with the correct order options.

Rugged Housing

The 3420 is suitable for field mounting in any Zone 2/Division 2 or general purpose area. A NEMA 4X/ IP65 enclosure allows the module to be mounted close to the process to minimize wiring.

Trending with Local Historian

The 3420 enables trending capabilities both in the webserver and in the host system. Multiple trends may be collected in the Webserver, with each trend able to collect and display data from a single measurement point, or a group of points. Trends may also be exported in Excel, CSV, or XML formats.

OPC Interface

The 3420 supports communication with host applications using OPC. Any standard output or parameter can be made available to the OPC client application. This is configured using an easy web interface (Figure 1).

FIGURE 1. OPC Configuration



Modbus Interface

The 3420 can communicate with the host system using the Modbus protocol. Any standard measurement, status, or other parameter can be read by any Modbus host system. Register number assignments are configurable, allowing the 3420 registers to match the requirements of the Modbus host. This is configured using an easy to use web interface (Figure 2).

FIGURE 2. Modbus Configuration



Web Server

Configuration of the 3420 is accomplished using any PC with a standard web browser and secure Ethernet connection, eliminating the need for special software. User configurable monitoring pages allow measured values to be grouped and easily viewed with the web interface. Web pages can be viewed either over a dedicated network or connection to the user's Intranet. Username and password security is provided to prevent unauthorized access to the data.

Product Data Sheet

00813-0100-4023, Rev EA
February 2008

3420 Fieldbus Interface Module (FIM)

Asset Management

The 3420 extends all of the capabilities of AMS™ Suite to field devices. Comprehensive asset management capabilities, such as device configuration, comparing configurations, audit trail, calibration, alerts, and more are now available when using AMS Device Manager with the 3420. When used with AMS Asset Portal, AMS Device Manager can provide a means to make critical device data from the 3420 available over an entire enterprise using a standard web browser over a secure Ethernet connection.

User configurable alerts are available, allowing users to add value to measurement points. These alerts can be set to flag maintenance notifications, environmental emissions, use of safety showers, tank levels - the applications are unlimited.

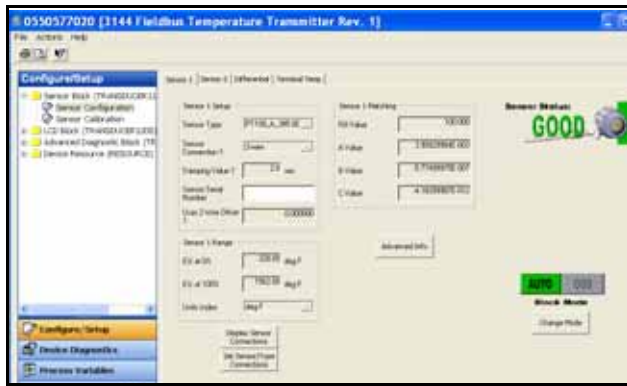
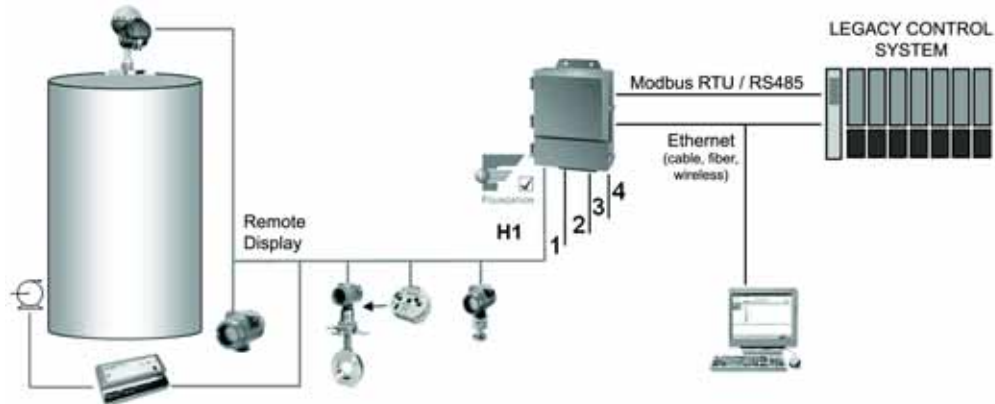

FIGURE 3. Fieldbus Point Monitor Screen

Point	Value	Status
00-100-00-1100-0107_01	FALSE	Good, Calibrate NonSpecific NonUnid
00-100-00-1100-0107_02	FALSE	Good, NonCalibrate NonSpecific NonUnid
00-100-00-1100-0107_03	DIFF: M, S, L, D, S, M, S, S and T	Good, NonCalibrate NonSpecific NonUnid
00-100-00-1100-0107_04	TRUE	Good, NonCalibrate NonSpecific NonUnid
00-100-00-1100-0107_05	TRUE	Good, NonCalibrate NonSpecific NonUnid
00-100-00-1100-0107_06	TRUE	Good, NonCalibrate NonSpecific NonUnid
00-100-00-1100-0107_07	TRUE	Good, NonCalibrate NonSpecific NonUnid
00-100-00-1100-0107_08	TRUE	Good, NonCalibrate NonSpecific NonUnid
00-100-00-1100-0107_09	TRUE	Good, NonCalibrate NonSpecific NonUnid
00-100-00-1100-0107_10	TRUE	Good, NonCalibrate NonSpecific NonUnid
00-100-00-1100-0107_11	TRUE	Good, NonCalibrate NonSpecific NonUnid
00-100-00-1100-0107_12	TRUE	Good, NonCalibrate NonSpecific NonUnid

FIGURE 4. Rosemount 3420 Fieldbus Interface Module with Modbus



3420 Fieldbus Interface Module (FIM)

Rosemount Products with FOUNDATION™ fieldbus

- Rosemount 848T Eight Input Temperature Transmitter provides the low installed cost solution for temperature monitoring applications
- Rosemount 848L Logic Transmitter supports discrete inputs, outputs, and logic processing
- Rosemount 752 Field Indicator displays up to 8 variables from any device on the fieldbus segment
- Rosemount 3144P Dual Sensor Temperature Transmitter with Hot-Backup and sensor drift alert
- Rosemount 3051S Series scalable P/DP transmitter. Providing 10 year stability and best in class performance
- Rosemount 5400 Radar Level Transmitter
- Rosemount 5600 Radar Level Transmitter
- Rosemount 8800C Vortex Flowmeter with Adaptive Digital Signal Processing ensures a stable, reliable output
- Rosemount 8742C Magnetic Flowmeter with grounding/wiring and high process noise advanced diagnostics

Products from other Emerson Process Management companies include digital valve controller, valve actuators, pH, Conductivity, and Oxygen transmitters, and gas chromatographs all with FOUNDATION fieldbus.



The 3420 powers *PlantWeb*® by working together with AMS Device Manager software to deliver the power of predictive intelligence with Emerson field devices.

Specifications

Functional Specifications

Power Input Options

24 V dc
 600 milliamps required to power a 3420 that does not power the fieldbus segment.
 1500 milliamps required to power a 3420 that powers the fieldbus segment.

Environmental

Operating Temperature Range:
 -40 to 60°C (-40 to 140°F) with internal power conditioners
 -40 to 70°C (-40 to 158°F) with power conditioners mounted externally
 Operating Humidity Range:
 0-95% relative humidity (non-condensing)

Performance Specifications

The rate at which the individual inputs are scanned depends on the number of Function Blocks enabled according to the following table:

TABLE 1. Scan Rate

Number of Blocks scanned on each segment	Scan rate
1	0.3 seconds
2	0.4 seconds
4	0.7 seconds
8	1.2 seconds
16	3.6 seconds
32	4.3 seconds
64	6.0 seconds
128	11.1 seconds

The Rosemount 848T temperature transmitter provides 8 AI blocks and 1 MAI block. An MAI block processes all eight inputs at once. The speed at which the 3420 scans all of the measurements from the devices on the fieldbus segments is dependent on the number of AI, MAI, and other function blocks being polled. For example, if a Rosemount 848T was polled with its MAI block, the scan time would be approximately 0.3 seconds. If the same device was polled with the AI blocks, the scan time would be about 1.2 seconds (see Table 1).

WARNING:

MODBUS and OPC are updated with asynchronous fieldbus messages. Do not attempt any critical control functions through MODBUS or OPC connection. (Typical updates vary 5 - 15 seconds, depending on fieldbus load.)

Physical Specifications

Weight

10.7 lb (4.85 kg)

Material of Construction

Housing Low-copper aluminum, NEMA 4X and IP65 IEC 529

Pollution Degree 2

Paint

Polyurethane

Cover Gasket

Rubber

Communication Specifications

RS485

2-wire communication link for Modbus multidrop connections
 Baud rate: 57600, 38400, 19200, or 9600
 Protocol: Modbus RTU
 Wiring: Single twisted shielded pair, 18 AWG. Wiring distance is approximately 5,000 ft. (1,524 m)

Ethernet

Security using Secure Socket Layer (SSL) and SSL tunnel, for Modbus TCP/IP and OPC.
 10baseT/ 100MBS Ethernet communication port,
 Optional 2nd Ethernet connection, Optional Optical Ethernet connection, Modbus TCP/IP, and OPC

Modbus

- Supports Modbus RTU and TCP/IP with 32 bit floating point value, integers, and scaled integers.
- Modbus registers are assigned to measurement inputs by the TAG of the analog input block.
- Modbus register numbers are specified by the user.
- The status of each variable is available in a 16 bit register.
- Modbus interface configuration is accomplished using web pages generated by the 3420.

H1 Fieldbus

Up to four H1 FOUNDATION fieldbus segments are supported. Up to 16 fieldbus devices can be connected to each H1 segment. The number of devices will depend on the power consumption of each device and the type of cable used. The 3420 internal power conditioners supply each H1 segment with 288 milliamps of current. Temperature applications using the 848T 8-input temperature transmitter exclusively can have up to 13 848T transmitters on each segment using the internal power conditioners.

When each option segment is ordered, it includes a power conditioner and terminator. The user is required to provide a second terminator for the field end of the segment. If external power conditioners are used, the user is responsible for providing both terminators for each segment and their mounting and wiring to the 3420.

3420 Fieldbus Interface Module (FIM)

It is recommended that external power conditioners be used in any critical applications. This will allow the 3420 to be removed for maintenance and allow the fieldbus segments to continue functioning should the 3420 be unavailable.

OPC

- Optional OPC server capability
- Web based configuration of OPC data elements such as measured values and function block outputs

Product Data Sheet

00813-0100-4023, Rev EA
February 2008

3420 Fieldbus Interface Module (FIM)

Product Certifications

Approved Manufacturing Locations

Rosemount Inc. – Chanhassen, Minnesota, USA
Rosemount Temperature GmbH – Germany
Emerson Process Management Private Limited – Singapore

European Union Directive Information

The EC declaration of conformity for all applicable European directives for this product can be found on the Rosemount website at www.rosemount.com. A hard copy may be obtained by contacting your local sales representative.

ATEX Directive (94/9/EC)

Rosemount Inc. complies with the ATEX Directive.

Electro Magnetic Compatibility (EMC) (89/336/EEC)

EN 50081-1: 1992; EN 50082-2:1995;
EN 61326-1:1997 – Industrial

CE CE Marking

Compliance with European Union EMC

Hazardous Location Certifications

North American Certifications

Factory Mutual (FM) Approvals

N5 FM Division 2 (Non-incendive)

Certificate Number: 3017645
Nonincendive for Class I, Division 2, Groups A,B,C, and D;
Dust Ignitionproof for Class II,III, Division 1,
Groups E,F, and G; Indoor/outdoor locations;
NEMA Type 4X
Temperature Code: T4 ($T_{amb} = -40^{\circ}\text{C}$ TO $+60^{\circ}\text{C}$)

Canadian Standards Association (CSA)

N6 CSA Division 2 & Dust Ignitionproof

Certificate Number: 1489720
Suitable for Class I, Division 2, Groups A,B,C,D;
Dust Ignitionproof for Class II, Groups E,F, and G;
Suitable for Class III Hazardous Locations.
Install per Rosemount drawing 03420-1011.
Temperature Code: T4($-40^{\circ}\text{C} < T_a < 60^{\circ}\text{C}$)
CSA Enclosure Type 4X

European Certification

N1 ATEX Type n

See note below
Certificate Number: Baseefa03ATEX0613X
ATEX Marking: Ex II 3 G
EEx nA nL IIC T4($-40^{\circ}\text{C} < T_a < 60^{\circ}\text{C}$)

IECEX Certification

N7 IECEX Type n

See note below
Certificate Number: IECEX BAS 04.0013X
Ex nC IIC T4 ($-40^{\circ}\text{C} = < T_a \leq +60^{\circ}\text{C}$)
Rated Voltage: 28V

CONDITIONS OF INSTALLING N1 AND N7:

The Apparatus is not capable of withstanding the 500V insulation test required by Clause 8 of IEC 79-15: 1987. This must be taken into account when installing the apparatus.

3420 Fieldbus Interface Module (FIM)

Dimensional Drawings

FIGURE 5. Rosemount 3420 Fieldbus Interface Module

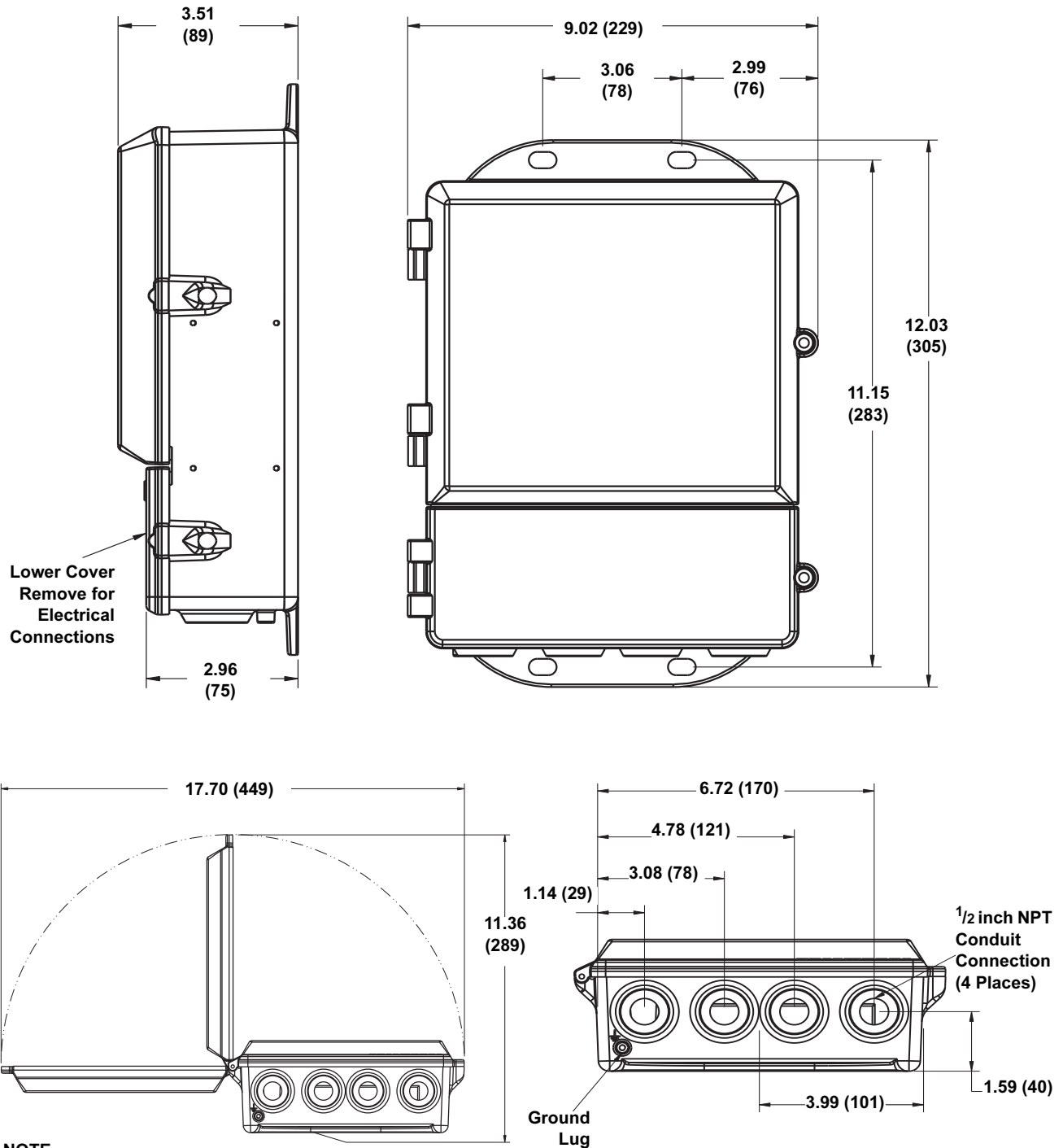

NOTE
Dimensions are in inches (millimeters).

Ordering Information

Model	Product Description
3420	Fieldbus Interface Module
Code	Power Input
A	24 VDC
Code	Output
1	RS485 + Ethernet
2	RS485 + Redundant Ethernet
3	RS485 + Fiber Optic Ethernet
Code	Fieldbus Input
A	One H1 Fieldbus Segment
B	Two H1 Fieldbus Segments
C	Three H1 Fieldbus Segments
D	Four H1 Fieldbus Segments
Code	Power Conditioner + Terminator for each segment
0	No power conditioner or terminator (must be supplied by others)
1	One power conditioner and terminator mounted in the 3420 housing ⁽¹⁾
2	Two power conditioners and terminator mounted in the 3420 housing ⁽¹⁾
3	Three power conditioners and terminator mounted in the 3420 housing ⁽¹⁾
4	Four power conditioners and terminator mounted in the 3420 housing ⁽¹⁾
Code	RS-485 Communication Options
N	No RS-485 Communication
A	Modbus RTU
Code	Ethernet Communication Options
0	Webserver and Modbus TCP/IP
1	OPC with Webserver and Modbus TCP/IP
2	AMS Ready Connectivity with Webserver and Modbus TCP/IP
4	AMS Ready Connectivity with OPC, Webserver and Modbus TCP/IP
Code	Other Options
Product Certifications	
N1	ATEX Type n
N5	Factory Mutual (FM) Division 2 Approval (non-incendive)
N6	Canadian Standards Association (CSA) Division 2 Approval
N7	IECEX Type n
Adapters	
J1	CM 20 Conduit Adapter
J2	PG 13.5 Conduit Adapter
Typical Model Number: 3420 A 1 A 1 N 0	

(1) Number of power conditioners must correspond to number of segments

3420 Fieldbus Interface Module (FIM)

Product Data Sheet

00813-0100-4023, Rev EA

February 2008

3420 Fieldbus Interface Module (FIM)

*Standard Terms and Conditions of Sale can be found at www.rosemount.com/terms_of_sale
Rosemount and the Rosemount logotype are registered trademarks of Rosemount Inc.
PlantWeb is a registered trademark of one of the Emerson Process Management group of companies.
All other marks are the property of their respective owners.
FOUNDATION is a trademark of the Fieldbus Foundation.
Modbus is a trademark of Modicon, Inc.
Cover Photo: 3402h_01.tif*

Standard Terms and Conditions of Sale can be found at www.rosemount.com/terms_of_sale

Emerson Process Management

Rosemount Inc.

8200 Market Boulevard
Chanhassen, MN 55317 USA
T (U.S.) 1-800-999-9307
T (International) (952) 906-8888
F (952) 949-7001

www.rosemount.com



Emerson Process Management

Heath Place
Bognor Regis
West Sussex PO22 9SH
England
Tel 44 (1243) 863 121
Fax 44 (1243) 867 554

Emerson Process Management Private Limited

1 Pandan Crescent
Singapore 128461
Tel (665) 6777 8211
Fax (665) 6777 0947
Enquiries@AP.Emersonprocess.com



EMERSON
Process Management