

TWO-WIRE TRANSMITTERS FOR pH, ORP, CONDUCTIVITY, OXYGEN, OZONE, AND CHLORINE

Model 5081 Family of Two-wire Transmitters

- CHOICE OF COMMUNICATION PROTOCOL: HART® or FOUNDATION Fieldbus.
- LARGE, EASY-TO-READ two-line display shows the process measurement and temperature.
- SIMPLE MENU STRUCTURE.
- ROBUST NEMA 4X and NEMA 7B ENCLOSURE.
- INTRINSICALLY SAFE DESIGN allows the transmitter to be used in hazardous environments (with appropriate safety barriers).
- NON-VOLATILE MEMORY retains program settings and calibration data during power failures.



FEATURES AND APPLICATIONS

The Model 5081 family of transmitters can be used to measure pH, ORP, conductivity (using either contacting or toroidal sensors), resistivity, oxygen (ppm and ppb level), free chlorine, total chlorine, and ozone in a variety of process liquids. The 5081 is compatible with most Rosemount Analytical sensors. See the Specification sections for details.

The transmitter has a rugged, weatherproof, corrosion-resistant enclosure (NEMA 4X and IP65) of epoxy-painted aluminum. The enclosure also meets NEMA 7B explosion-proof standards.

The transmitter has a two-line seven-segment display. The main measurement appears in 0.8-inch (20 mm) high numerals. The secondary measurement, temperature (and pH if free chlorine is being measured), appears in 0.3-inch (7 mm) high digits.

Two digital communication protocols are available: HART (model option -HT) and Foundation Fieldbus (model options -FF or -FI). Digital communications allows access to AMS (Asset Management Solutions). Use AMS to set up and configure the transmitter, read process variables, and troubleshoot problems from a personal computer or host anywhere in the plant.

A handheld infrared remote controller or the HART and Foundation Fieldbus Model 375 communicator can also be used for programming and calibrating the transmitter. The remote controller works from as far away as six feet.



Model 5081-P pH/ORP Transmitter

- CHANGING FROM pH TO ORP operation takes only seconds.
- AUTOMATIC TWO-POINT BUFFER CALIBRATION reduces errors.
- SOLUTION TEMPERATURE COMPENSATION converts measured pH to the pH at 25°C.
- CONTINUOUS DIAGNOSTICS monitor sensor performance and warn the user of failure (FAULT) or approaching failure (WARNING).

Model 5081-C Contacting Conductivity Transmitter

- MEASURES CONDUCTIVITY, RESISTIVITY, OR CUSTOM CURVE VARIABLE.
- AUTOMATIC TC RECOGNITION simplifies start up.
- AUTOMATIC/MANUAL TEMPERATURE COMPENSATION ensures accurate monitoring and control.
- AUTOMATIC COMPENSATION FOR SENSOR CABLE RESISTANCE improves accuracy of high conductivity/ low resistivity measurements.
- BUILT-IN TEMPERATURE COMPENSATION ALGORITHMS include straight slope, ultra-pure water, cation conductivity, and no compensation.



Model 5081-T Toroidal Conductivity Transmitter

- MEASURES CONDUCTIVITY, PERCENT CONCENTRATION, OR CUSTOM CURVE VARIABLE.
- AUTOMATIC TC RECOGNITION simplifies start up.
- AUTOMATIC/MANUAL TEMPERATURE COMPENSATION ensures accurate monitoring and control.
- BUILT-IN CONCENTRATION CURVES FOR 0-12% NaOH, 0-15% HCl, 0-25% and 96-99.7% H₂SO₄.
- PROGRAMMABLE REFERENCE TEMPERATURE enables temperature compensation to temperatures other than 25 degrees Celsius.
- AUTOMATIC COMPENSATION FOR SENSOR CABLE RESISTANCE improves accuracy of high conductivity measurements.



Model 5081-A Amperometric Transmitter

- MEASURES dissolved oxygen (ppm and ppb level), free chlorine, total chlorine, and ozone.
- SECOND INPUT FOR A pH SENSOR ALLOWS AUTOMATIC pH CORRECTION for free chlorine measurement. No expensive, messy reagents needed.
- AUTOMATIC BUFFER RECOGNITION FOR pH CALIBRATION.



SPECIFICATIONS - GENERAL

Housing: Cast aluminum with epoxy coating. NEMA 4X (IP65) and NEMA 7B. Neoprene O-ring cover seals. 160.5 mm x 175.3 mm x 161.3 mm (6.3 in. x 6.9 in. x 6.4 in.)

Dimensions: See drawing.

Conduit Openings: ¾-in. NPT

Ambient Temperature: -4 to 149°F (-20 to 65°C)

Storage Temperature: -22 to 176°F (-30 to 80°C)

Relative Humidity: 0 to 95% (non-condensing)

Weight/Shipping Weight: 10 lb/11 lb (4.5/5.0 kg)

Display: Two-line LCD; first line shows process variable (pH, ORP, conductivity, % concentration, oxygen, ozone, or chlorine), second line shows process temperature and output current. For pH/chlorine combination, the second line can be toggled to show pH. Fault and warning messages, when triggered, alternate with temperature and output readings.

First line: 7 segment LCD, 0.8 in. (20 mm) high.

Second line: 7 segment LCD, 0.3 in. (7mm) high.

Display board can be rotated 90 degrees clockwise or counterclockwise.

During calibration and programming, messages and prompts appear in the second line.

Temperature resolution: 0.1°C

Hazardous Location Approval: For details, see specifications for the measurement of interest.

RFI/EMI: EN-61326 

Digital Communications: For details, see specifications for the measurement of interest.

Specifications subject to change without notice.

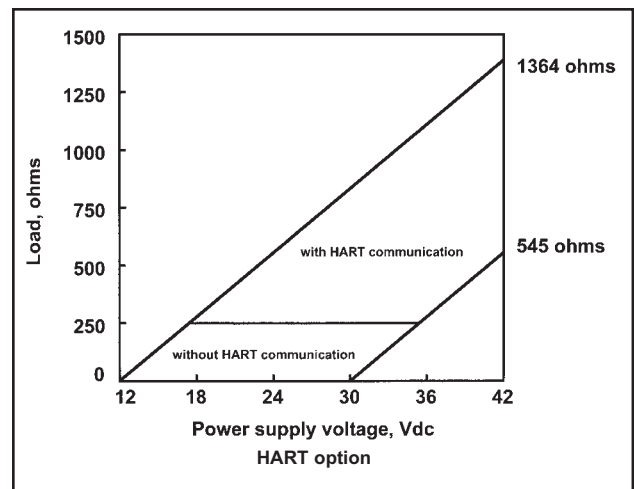

HART —

Power & Load Requirements:

Supply voltage at the transmitter terminals should be at least 12 Vdc. Power supply voltage should cover the voltage drop on the cable plus the external load resistor required for HART communications (250 Ω minimum). Minimum power supply voltage is 12 Vdc. Maximum power supply voltage is 42.4 Vdc (30 Vdc for intrinsically safe operation). The graph shows the supply voltage required to maintain 12 Vdc (upper line) and 30 Vdc (lower line) at the transmitter terminals when the current is 22 mA.

Analog Output: Two-wire, 4-20 mA output with superimposed HART digital signal. Fully scalable over the operating range of the sensor.

Output accuracy: ±0.05 mA

FOUNDATION fieldbus —

Power & Load Requirements: A power supply voltage of 9-32 Vdc at 22 mA is required.

Fieldbus Intrinsically Safe COnccept/FISCO-compliant versions of Model 5081 Foundation Fieldbus transmitter are available.

MODEL 5081-P pH/ORP TRANSMITTER

FEATURES

The Model 5081-P Transmitter with the appropriate sensor can be configured for either pH or ORP (oxidation reduction potential) measurement of aqueous solutions. Housed in a NEMA 4X and NEMA 7 case, the Model 5081 can be located close to the sensor even in the harshest environments, including process, water or wastewater monitoring. Advanced features include automatic 2-point buffer calibration routine, automatic recognition of Pt100 or Pt1000 RTD, and menu-selected internal preamplifier. Predictive sensor diagnostic capability is possible through the impedance measurement of the pH glass membrane and reference electrode, fully supported by AMS. Solution temperature calibration allows the instrument to calculate and display the pH at 25°C when the temperature coefficient of the measured liquid is provided.

FUNCTIONAL SPECIFICATIONS

pH Range: 0 to 14

ORP Range: -1400 to +1400mV

Calibrations/standardization: The automatic buffer recognition uses stored buffer values and their temperature curves for the most common buffer standards available worldwide. The transmitter also performs a stabilization check on the sensor in each buffer.

A manual two-point calibration is made by immersing the sensor in two different buffer solutions and entering the pH values. The microprocessor automatically calculates the slope which is used for self-diagnostics. An error message will be displayed if the pH sensor is faulty. This slope can be read on the display and/or manually adjusted if desired.

An on-line one-point process standardization is accomplished by entering the pH or ORP value of a grab sample.

Preamplifier Location: A preamplifier must be used to convert the high impedance pH electrode signal to a low impedance signal for transmitter use. The integral preamplifier of the Model 5081-P may be used when the sensor to transmitter distance is less than 15 ft (4.5 m). Locate the preamplifier in the sensor or junction box for longer distances.

Automatic Temperature Compensation: External 3 or 4 wire Pt 100 RTD or Pt 1000 RTD located in the sensor, compensates the pH reading for temperature fluctuations. Compensation covers the range -15 to 130°C (5 to 270°F). Manual temperature compensation is also selectable.

Accuracy: ±1 mV @ 25°C ±0.01 pH

Repeatability: ±1 mV @ 25°C ±0.01 pH

Stability: 0.25% / year @ 25°C

Diagnostics: The internal diagnostics can detect:

Calibration Error	Low Temperature Error
High Temperature Error	Sensor Failure
Line Failure	CPU Failure
ROM Failure	Input Warning
Glass Failure	Glass Warning
Reference Failure	Reference Warning

Once one of the above is diagnosed, the LCD will display a message describing the failure/default detected.

Digital Communications:

HART (pH): PV assigned to pH. SV, TV, and 4V assignable to pH, temperature, mV, glass impedance, reference impedance, or RTD resistance.

HART (ORP): PV assigned to ORP. SV, TV, and 4V assignable to ORP, temperature, reference impedance, or RTD resistance.

Fieldbus (pH): Four AI blocks assigned to pH, temperature, reference impedance, and glass impedance.

Fieldbus (ORP): Three AI blocks assigned to ORP, temperature, and reference impedance.

Fieldbus (pH and ORP): Execution time 75 msec. One PID block; execution time 150 msec. Device type 4085. Device revision 1. Certified to ITK 4.5.

SENSOR COMPATIBILITY CHART

pH/ORP SENSOR	DIAGNOSTIC CAPABILITY
320HP-58	Glass only
328A	Glass only
370	Glass only
371	Glass only
372	Glass only
381 pHE-31-41-52	Glass only
381+	Glass and Reference
385+	Glass and Reference
389-02-54 / 389VP-54	Glass only
396-54-62 / 396VP	Glass only
396P-55 / 396PVP-55	Glass and Reference
396R / 396RVP-54	Glass and Reference
397-54-62	Glass only
398-54-62 / 398VP-54	Glass only
398R-54-62 / 398RVP-54	Glass only
399-09-62 / 399VP-09	Glass only
Hx338	Glass only
Hx348	Glass only
TF396	none

MODEL 5081-P pH/ORP TRANSMITTER

HAZARDOUS LOCATION APPROVAL

Intrinsic Safety (with appropriate safety barrier):



Class I, II, III, Div. 1
Groups A-G
T4 Tamb = 70°C



Exia Entity
Class I, Groups A-D
Class II, Groups E-G
Class III
T4 Tamb = 70°C

ATEX

CE 0600 II 1 G



Baseefa02ATEX1284
EEx ia IIC T4
Tamb = -20°C to +65°C

Non-Incendive:



Class I, Div. 2, Groups A-D
Dust Ignition Proof
Class II & III, Div. 1, Groups E-G
NEMA 4X Enclosure



Class I, Div. 2, Groups A-D
Suitable for
Class II, Div. 2, Groups E-G
T4 Tamb = 70°C

Explosion-Proof:



Class I, Div. 1, Groups B-D
Class II, Div. 1, Groups E-G
Class III, Div. 1



Class I, Groups B-D
Class II, Groups E-G
Class III
Tamb = 65°C max

MODEL 5081-A AMPEROMETRIC TRANSMITTER

FEATURES

The Model 5081-A Transmitter with the appropriate sensor measures dissolved oxygen (ppm and ppb level), free chlorine, total chlorine, and ozone in a variety of process liquids. The transmitter is compatible with Rosemount Analytical 499A amperometric sensors for oxygen, chlorine, and ozone; and with Hx438 and Gx448 steam-sterilizable oxygen sensors.

For free chlorine measurements, both automatic and manual pH correction are available. pH correction is necessary because amperometric chlorine sensors respond only to hypochlorous acid, not free chlorine, which is the sum of hypochlorous acid and hypochlorite ion. To measure free chlorine, most competing instruments require an acidified sample. Acid lowers the pH and converts hypochlorite ion to hypochlorous acid. The Model 5081-A eliminates the need for messy and expensive sample conditioning by measuring the

GENERAL SPECIFICATIONS FOR 5081-A

Input ranges: 0-330 nA, 0.3-4 μ A, 3.7-30 μ A, 27-100 μ A

Repeatability (input): \pm 0.1% of range

Linearity (input): \pm 0.3% of range

Temperature range: 0-100°C (0-150°C for steam sterilizable sensors)

Temperature accuracy using RTD: \pm 0.5°C between 0 and 50°C, \pm 1°C above 50°C

Temperature accuracy using 22k NTC: \pm 0.5°C between 0 and 50°C, \pm 2°C above 50°C

Digital Communications:

HART: PV, SV, TV, and 4V assignable to measurement (oxygen, ozone, or chlorine), temperature, pH, and sensor current.

Fieldbus: Four (4) AI blocks assignable to measurement (oxygen, ozone, or chlorine), temperature, pH, and sensor current; execution time 75 msec. One PID block; execution time 150 msec. Device type: 4083. Device revision: 1. Certified to ITK 4.01.

SPECIFICATIONS — OXYGEN

Measurement Range: 0-99 ppm (mg/L), 0-200% saturation

Resolution: 0.01 ppm, 0.1 ppb for 499A TrDO sensor

Temperature correction for membrane permeability: automatic between 0 and 50°C (can be disabled)

Calibration: air calibration (user must enter barometric pressure) or calibration against a standard instrument

SENSORS — OXYGEN:

Model 499A DO-54 for ppm level

Model 499A TrDO-54 for ppb level

Hx438 and Gx448 steam-sterilizable oxygen sensors

SPECIFICATIONS — FREE CHLORINE

Measurement Range: 0-20 ppm (mg/L) as Cl₂

Resolution: 0.001 ppm (Autoranges at 0.999 to 1.00 and 9.99 to 10.0)

Temperature correction for membrane permeability: automatic between 0 and 50°C (can be disabled)

sample pH and using it to correct the chlorine sensor signal. If the pH is relatively constant, a fixed pH correction can be used, and the pH measurement is not necessary. If the pH is greater than 7.0 and fluctuates more than about 0.2 units, continuous measurement of pH and automatic pH correction is necessary. See Specifications section for recommended pH sensors. Corrections are valid to pH 9.5.

The transmitter fully compensates oxygen, ozone, free chlorine, and total chlorine readings for changes in membrane permeability caused by temperature changes.

For pH measurements — pH is available with free chlorine only — the 5081-A features automatic buffer recognition and stabilization check. Buffer pH and temperature data for commonly used buffers are stored in the transmitter. Glass impedance diagnostics warn the user of an aging or failed pH sensor.

pH Correction: Automatic between pH 6.0 and 9.5. Manual pH correction is also available.

Calibration: against grab sample analyzed using portable test kit.

SENSOR — FREE CHLORINE:

Model 499A CL-01-54

SPECIFICATIONS — pH

Application: pH measurement available with free chlorine only

Measurement Range: 0-14 pH

Resolution: 0.01 pH

Sensor Diagnostics: Glass impedance (for broken or aging electrode) and reference offset. Reference impedance (for fouled reference junction) is not available.

Repeatability: \pm 0.01 pH at 25°C

SENSORS — pH:

Use Model 399-09-62, 399-14, or 399VP-09.

SPECIFICATIONS — TOTAL CHLORINE

Measurement Range: 0-20 ppm (mg/L) as Cl₂

Resolution: 0.001 ppm (Autoranges at 0.999 to 1.00 and 9.99 to 10.0)

Temperature correction for membrane permeability: automatic between 5 and 35°C (can be disabled)

Calibration: against grab sample analyzed using portable test kit.

SENSOR — TOTAL CHLORINE:

Model 499A CL-02-54 (must be used with SCS 921)

SPECIFICATIONS — OZONE

Measurement Range: 0-10 ppm (mg/L)

Resolution: 0.001 ppm (Autoranges at 0.999 to 1.00 and 9.99 to 10.0)

Temperature correction for membrane permeability: automatic between 5 and 35°C (can be disabled)

Calibration: against grab sample analyzed using portable test kit.

SENSOR — OZONE:

Model 499A OZ-54

MODEL 5081-A AMPEROMETRIC TRANSMITTER

HAZARDOUS LOCATION APPROVAL

Intrinsic Safety (with appropriate safety barrier):



Class I, II, III, Div. 1
Groups A-G
T4 Tamb = 70°C



Exia Entity
Class I, Groups A-D
Class II, Groups E-G
Class III
T4 Tamb = 70°C

ATEX

CE 0600 II 1 G



Baseefa02ATEX1284
EEx ia IIC T4
Tamb = -20°C to +65°C

Non-Incendive:



Class I, Div. 2, Groups A-D
Dust Ignition Proof
Class II & III, Div. 1, Groups E-G
NEMA 4X Enclosure



Class I, Div. 2, Groups A-D
Suitable for
Class II, Div. 2, Groups E-G
T4 Tamb = 70°C

Explosion-Proof:



Class I, Div. 1, Groups B-D
Class II, Div. 1, Groups E-G
Class III, Div. 1



Class I, Groups B-D
Class II, Groups E-G
Class III
Tamb = 65°C max

MODEL 5081-C CONTACTING CONDUCTIVITY TRANSMITTER

FEATURES

Housed in a rugged NEMA 4X and NEMA 7 case, the 5081C measures conductivity or resistivity in the harshest environments. Transmitter can also be configured, using the "Custom Curve" feature, to measure ppm, %, or a no unit variable according to a programmable conductivity vs. variable curve. The transmitter will automatically recognize the type of RTD (Pt100 or Pt1000) being used. Measurements are automatically corrected for the resistance of the sensor cable to improve accuracy of high conductivity readings. The 5081C provides several temperature compensation algorithms to ensure optimal performance: linear slope, ultra-pure water (neutral salt), or cation conductivity. Alternatively, temperature compensation feature can be turned off to provide display of raw conductivity.

FUNCTIONAL SPECIFICATIONS

Calibration: Calibration is easily accomplished by immersing the sensor in a known solution and entering its value or entering the cell constant for ultra pure applications.

Automatic Temperature Compensation:

- 3-wire Pt 100 or Pt 1000 RTD
- Conductivity: 0 to 200°C (32 to 392°F)
- Resistivity: 0 to 100°C (32 to 212°F)
- Low Conductivity: 0 to 100°C (32 to 212°F)

Diagnostics: The internal diagnostics can detect:

- Calibration Error
- Temperature Slope Error
- High Temperature Error
- Line Failure
- ROM Failure
- Zero Error
- Low Temperature Error
- Sensor Failure
- CPU Failure
- Input Warning

Once one of the above is diagnosed, the LCD will display a message describing the failure/default detected.

Digital Communications:

HART: PV, SV, and TV assignable to measurement (conductivity, resistivity, or concentration), temperature, and raw conductivity. Raw conductivity is measured conductivity before temperature correction.

Fieldbus: Three AI blocks assignable to measurement (conductivity, resistivity, or concentration), temperature, and raw conductivity. Raw conductivity is measured conductivity before temperature correction. Execution time 75 msec. One PID block; execution time 150 msec. Device type: 4084. Device revision: 1. Certified to ITK 4.5.

TRANSMITTER SPECIFICATIONS @ 25°C

Measured Range: 0-20,000 µS/cm

Accuracy: ± 0.5% of reading and ± 0.001 µS/cm

Repeatability: ± 0.25% of reading

Stability: 0.25% of output range/month, non-cumulative

Ambient Temperature Coefficient:
± 0.05% of reading/°C

Temperature Slope Adjustment: 0-5%/°C

Other temperature compensation algorithms: ultra-pure water compensation, cation conductivity, or raw (uncompensated) conductivity.

Compatible RTD: 100Ω or 1000Ω with Automatic Recognition

LOOP SPECIFICATIONS

Accuracy: under controlled laboratory conditions at 25°C (77°F) with perfectly calibrated ENDURANCE sensor of appropriate cell constant:

up to 5,000 µS/cm: ± 1.0% and ± 2 least significant digit

from 5,000 to 20,000: ± 2% of reading and ± 2 least significant digit

SENSOR SELECTION GUIDELINES

Cell Constant	Suggested Conductivity Range
0.01/cm	up to 50 µS/cm
0.1/cm	1.0 to 500 µS/cm
1.0/cm	10 to 20,000 µS/cm

Note: The conductivity values shown in the above chart are for UNCOMPENSATED (or RAW) conductivity at 25°C. Maximum range values will vary due to temperature compensation selection, process temperature, and other process conditions.

RECOMMENDED SENSORS:

- Model 140 Retractable Conductivity
- Model 141 Insertion High Conductivity
- Model 142 Insertion Low Conductivity
- Model 150 Insertion/Submersion Conductivity
- Model 400 Screw-In Low Conductivity
- Model 400VP Screw-In Low Conductivity
- Model 401 Screw-In High Conductivity
- Model 402 Retractable Conductivity
- Model 402VP Retractable Conductivity
- Model 403 Sanitary Conductivity
- Model 403VP Sanitary Conductivity
- Model 404 Low Flow Conductivity

MODEL 5081-C CONTACTING CONDUCTIVITY TRANSMITTER

HAZARDOUS LOCATION APPROVAL

Intrinsic Safety (with appropriate safety barrier):



Class I, II, III, Div. 1
Groups A-G
T4 Tamb = 70°C



Exia Entity
Class I, Groups A-D
Class II, Groups E-G
Class III
T4 Tamb = 70°C

ATEX



CE 1180
II 1 G
Baseefa03ATEX0099
EEx ia IIC T4
Tamb = -20°C to +65°C

Non-Incendive:



Class I, Div. 2, Groups A-D
Dust Ignition Proof
Class II & III, Div. 1, Groups E-G
NEMA 4X Enclosure



Class I, Div. 2, Groups A-D
Suitable for
Class II, Div. 2, Groups E-G
T4 Tamb = 70°C

Explosion-Proof:



Class I, Div. 1, Groups B-D
Class II, Div. 1, Groups E-G
Class III, Div. 1



Class I, Groups B-D
Class II, Groups E-G
Class III
Tamb = 65°C max

MODEL 5081-T TOROIDAL CONDUCTIVITY TRANSMITTER

FEATURES

Housed in a rugged NEMA 4X and NEMA 7 case, the 5081T measures conductivity or % concentration in the harshest environments. Transmitter can also be configured, using the "Custom Curve" feature, to measure ppm, %, or a no unit variable according to a programmable conductivity vs. variable curve. The transmitter will automatically recognize the type of RTD (Pt100 or Pt1000) being used. Measurements are automatically corrected for the resistance of the sensor cable to improve accuracy of high conductivity readings. The 5081T is preprogrammed with several percent concentration curves: 0-12% NaOH, 0-15% HCl, 0-30% and 96-99.7% H₂SO₄. Temperature compensation choices are linear slope correction or none (to provide display of raw conductivity).

FUNCTIONAL SPECIFICATIONS

Calibration: Calibration is easily accomplished by immersing the sensor in a known solution and entering its value.

Automatic Temperature Compensation:

- 3-wire Pt 100 RTD
- Conductivity: 0 to 200°C (32 to 392°F)
- % Concentration: 0 to 100°C (32 to 212°F)

Diagnostics: The internal diagnostics can detect:

- Calibration Error Zero Error
- Temperature Slope Error Low Temperature Error
- High Temperature Error Sensor Failure
- Line Failure CPU Failure
- ROM Failure Input Warning

Once one of the above is diagnosed, the LCD will display a message describing the failure/default detected.

Digital Communications:

HART: PV, SV, and TV assignable to measurement (conductivity, resistivity, or concentration), temperature, and raw conductivity. Raw conductivity is measured conductivity before temperature correction.

Fieldbus: Three AI blocks assignable to measurement (conductivity, resistivity, or concentration), temperature, and raw conductivity. Raw conductivity is measured conductivity before temperature correction. Execution time 75 msec. One PID block; execution time 150 msec. Device type: 4084. Device revision: 1. Certified to ITK 4.5.

TRANSMITTER SPECIFICATIONS @ 25°C

- Measured Range*:** 50 to 2,000,000 µS/cm (see chart)
- Accuracy:** ± 1.0% of reading
- Repeatability:** ± 0.25% of reading
- Stability:** 0.25% of output range/month, non-cumulative
- Ambient Temperature Coefficient:** ± 0.1% of reading ±2 µS/cm per °C
- Temperature Slope Adjustment:** 0-5%/° C
- % Concentration Ranges:**
 - Sodium Hydroxide: 0 to 12%
 - Hydrochloric Acid: 0 to 15%
 - Sulfuric Acid: 0 to 25% and 96 to 99.7%

LOOP SPECIFICATIONS

Loop Accuracy: With a standard Model 228 or 225 sensor with 20' cable, laboratory accuracy at 25°C can be as good as ±2% of reading and ±50 µS/cm. To achieve optimum performance, standardize the sensor in the process at the conductivity and temperature of interest.

Results under real process conditions, at different temperatures, or using other sensors may differ from above.

RTD accuracy: Utilizing a perfect 100 Ohm RTD after 1 point temperature standardization, temperature reading can be as good as ±0.5°C.

RECOMMENDED SENSORS:

- Model 222 Flow-Through
- Model 225 Clean-In-Place (CIP)
- Model 226 Submersion/Insertion
- Model 228 Submersion/Insertion/Retractable
- Model 242* Flow-Through

*no I.S. approval for loops of 5081-T with 242-06 or 242-08

RECOMMENDED RANGES FOR TOROIDAL SENSORS						
Conductivity Sensor Model Number	226	228	225	222 (1in.)	222 (2 in.)	242
Nominal Cell Constant	1.0	3.0	3.0	6.0	4.0	*
Minimum Conductivity (µS/cm)	50	200	200	500	500	100*
Maximum Conductivity (µS/cm)	1,000,000	2,000,000	2,000,000	2,000,000	2,000,000	2,000,000*

* Model 242 values depend on sensor configuration and wiring.

NOTE: Values shown are for 25°C conductivity with a temperature slope of 2% per °C. The maximum range value will be lower for solutions with a higher temperature slope. Minimum conductivity depends on sensor.

MODEL 5081-T CONTACTING TOROIDAL TRANSMITTER

HAZARDOUS LOCATION APPROVAL

Intrinsic Safety (with appropriate safety barrier):



Class I, II, III, Div. 1
Groups A-G
T4 Tamb = 70°C



Exia Entity
Class I, Groups A-D
Class II, Groups E-G
Class III
T4 Tamb = 70°C

ATEX



CE 0600
II 1 G
Baseefa03ATEX0399
EEx ia IIC T4
Tamb = -20°C to +65°C

Non-Incendive:



Class I, Div. 2, Groups A-D
Dust Ignition Proof
Class II & III, Div. 1, Groups E-G
NEMA 4X Enclosure



Class I, Div. 2, Groups A-D
Suitable for
Class II, Div. 2, Groups E-G
T4 Tamb = 70°C

Explosion-Proof:



Class I, Div. 1, Groups B-D
Class II, Div. 1, Groups E-G
Class III, Div. 1



Class I, Groups B-D
Class II, Groups E-G
Class III
Tamb = 65°C max

TRANSMITTER DISPLAY DURING CALIBRATION AND PROGRAMMING (FIGURE 1)

1. Continuous display of pH, ORP, conductivity, oxygen, chlorine, or ozone reading.
2. Units: pH, mV, $\mu\text{S}/\text{cm}$, mS/cm , ppm, ppb, or % saturation.
3. Current menu appears here.
4. Submenus, prompts, and diagnostic readings appear here.
5. Commands available in each submenu or at each prompt appear here.
6. Hold appears when the transmitter is in hold.
7. Fault appears when the transmitter detects a sensor or instrument fault.
8. ♥ flashes during digital communication.

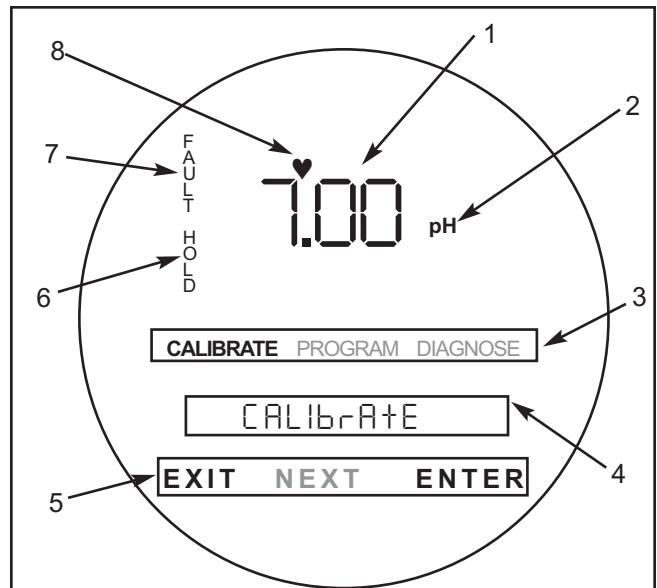

FIGURE 1. TRANSMITTER DISPLAY DURING CALIBRATION AND PROGRAMMING

The program display screen allows access to calibration and programming menus.

INFRARED REMOTE CONTROLLER (FIGURE 2)

1. Pressing a menu key allows the user access to calibrate, program, or diagnostic menus.
2. Press ENTER to store data and settings. Press NEXT to move from one submenu to the next. Press EXIT to leave without storing changes.
3. Use the editing keys to scroll through lists of allowed settings or to change a numerical setting to the desired value.
4. Pressing HOLD puts the transmitter in hold and sends the output current to a pre-programmed value. Pressing RESET causes the transmitter to abandon the present operation and return to the main display.

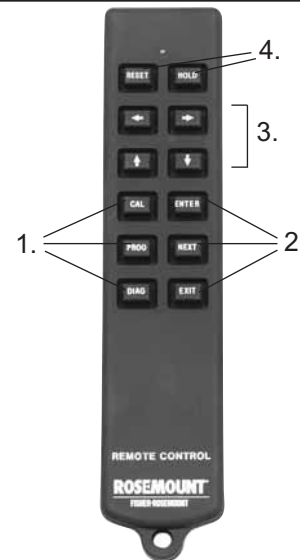

FIGURE 2. INFRARED REMOTE CONTROLLER

HART COMMUNICATION (FIGURE 3)

Figure 3 shows how HART communication can be used with the Model 5081-HT. Use HART to configure and read process variables using the Model 375 HART Communicator, a personal computer, or any other hosts that support HART communication protocol. HART allows communication through to AMS.

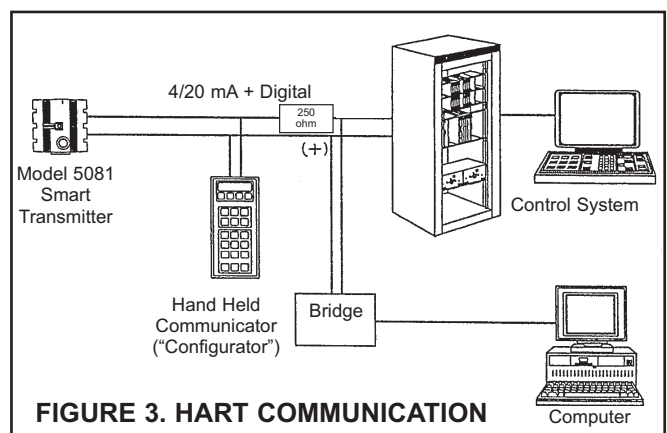

FIGURE 3. HART COMMUNICATION

FOUNDATION FIELDBUS (FIGURE 4)

Figure 4 shows a 5081-A-FF being used to measure and control pH and chlorine levels in drinking water. The figure also shows three ways in which Fieldbus communication can be used to read process variables and configure the transmitter.

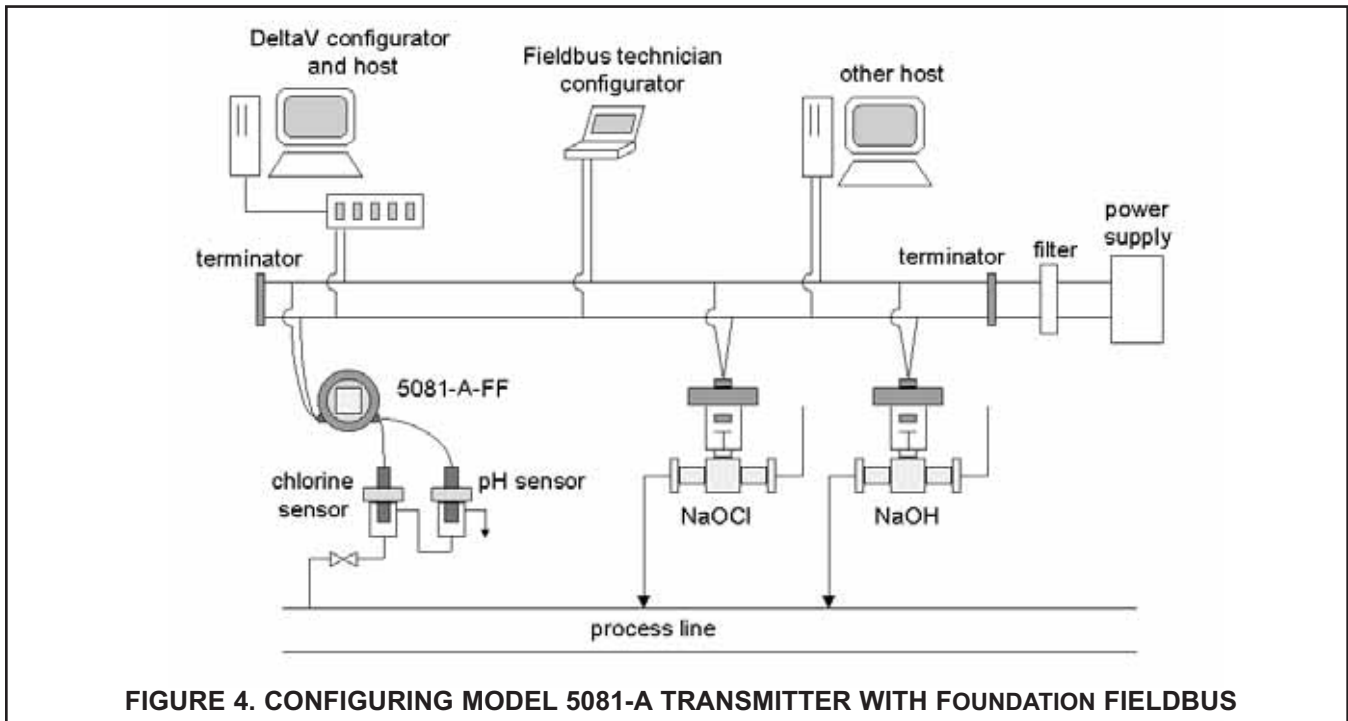

FIGURE 4. CONFIGURING MODEL 5081-A TRANSMITTER WITH FOUNDATION FIELDBUS

ASSET MANAGEMENT SOLUTIONS (AMS) (FIGURES 5, 6, and 7)

Rosemount Analytical AMS windows provide access to all transmitter measurement and configuration variables. The user can read raw data, final data, and program settings and can reconfigure the transmitter from anywhere in the plant. Figures 5 and 6 show two of the many configuration and measurement screens available using HART AMS. Figure 7 shows a configuration screen available through AMS Inside using FOUNDATION Fieldbus.

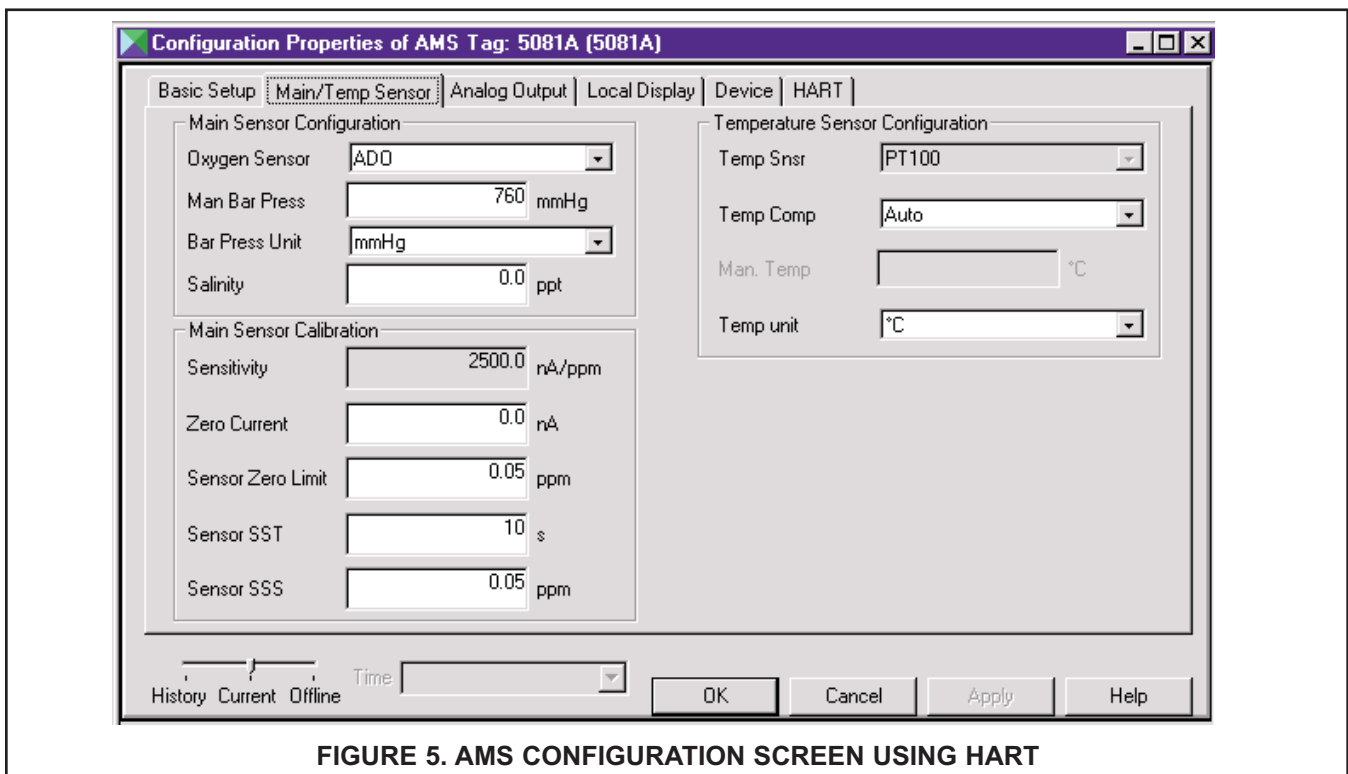

FIGURE 5. AMS CONFIGURATION SCREEN USING HART

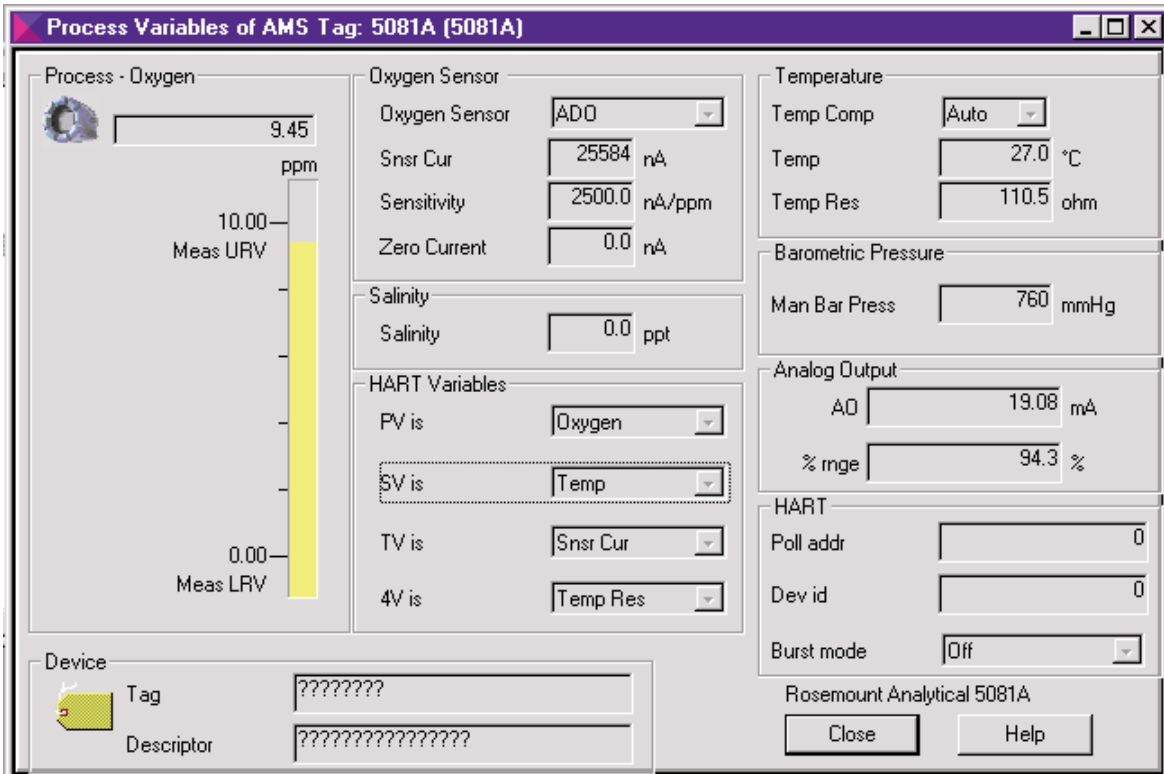

FIGURE 6. AMS MEASUREMENT SCREEN USING HART

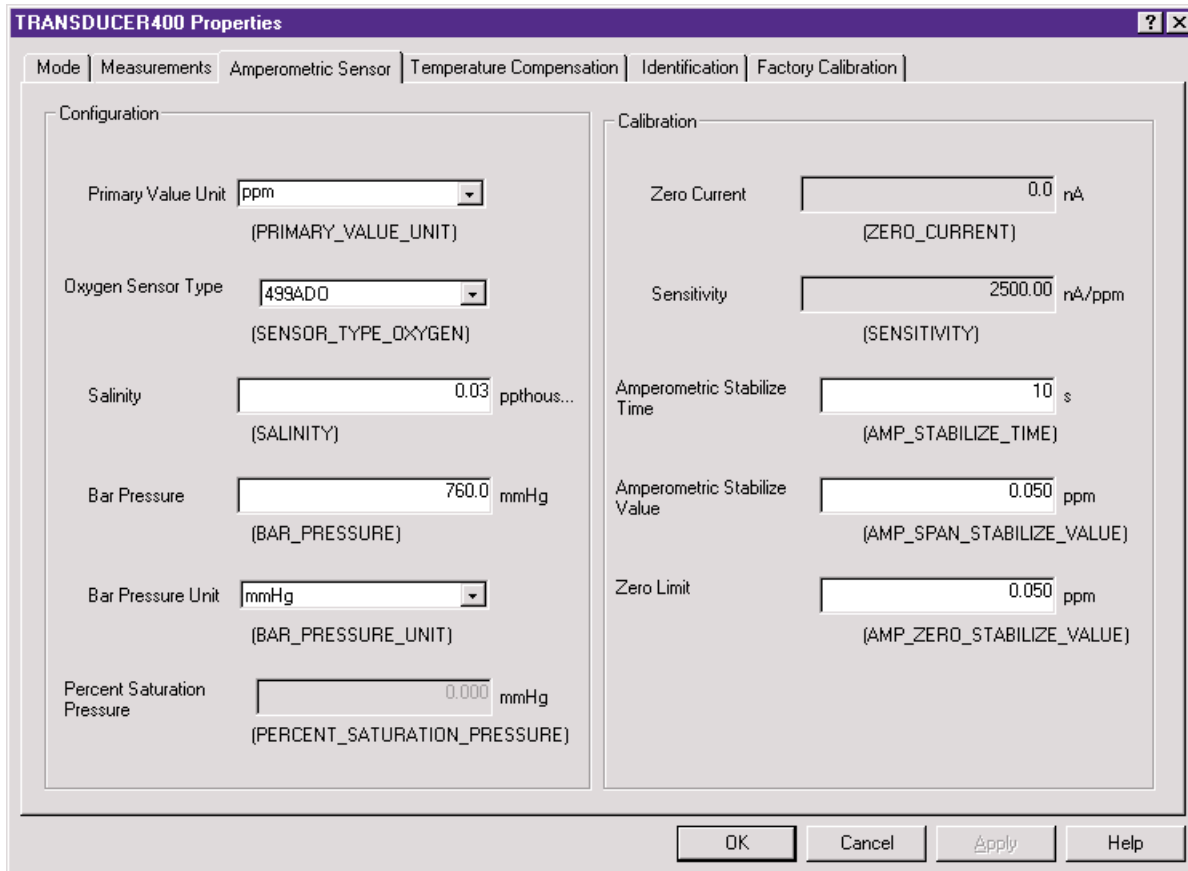
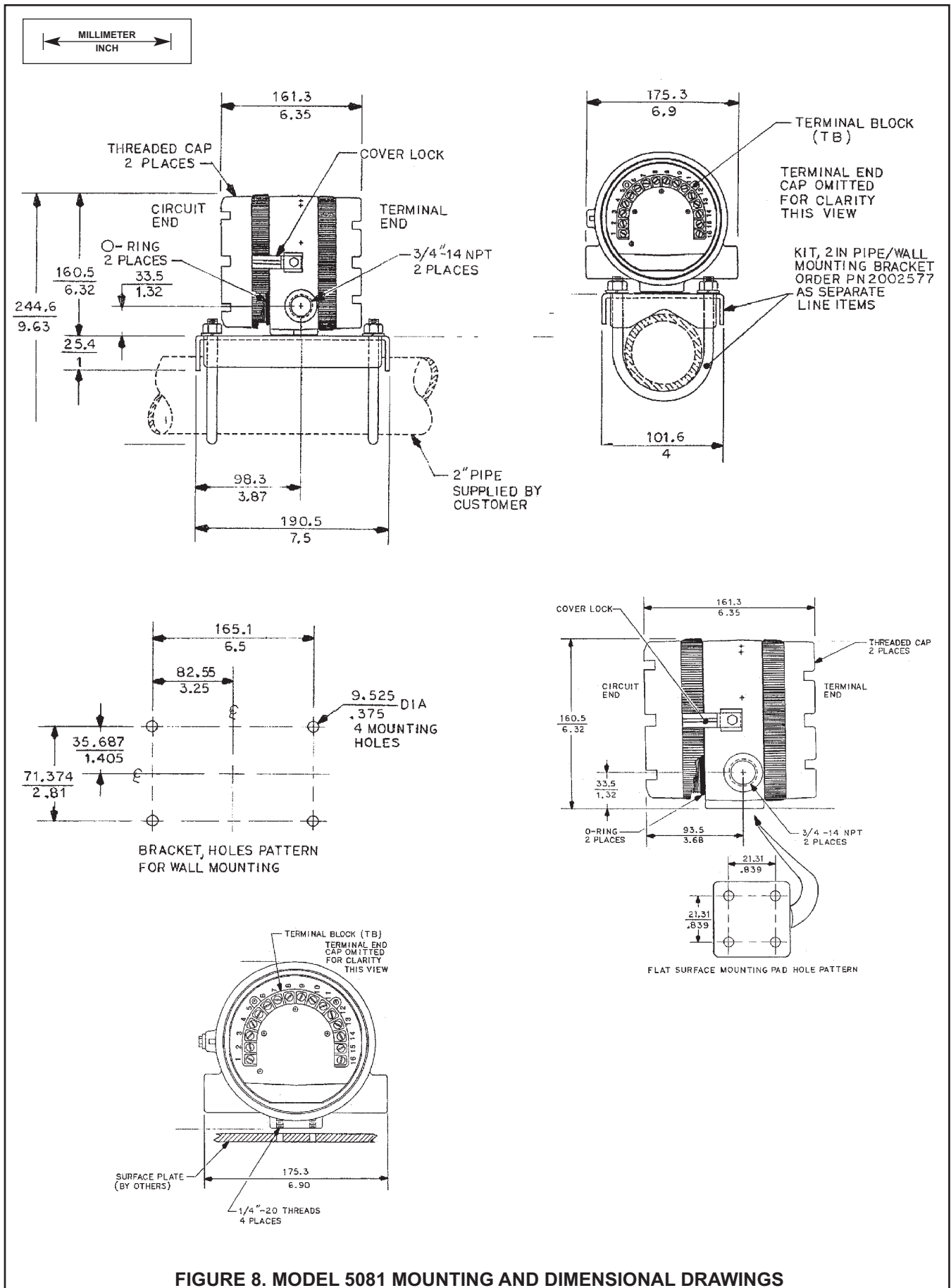

FIGURE 7. AMS INSIDE CONFIGURATION SCREEN USING FOUNDATION FIELDBUS



ORDERING INFORMATION

The **Model 5081 Two-Wire Transmitter** is intended for the determination of pH/ORP, conductivity (both contacting and toroidal), and for measurements using membrane-covered amperometric sensors (oxygen, ozone, and chlorine). For free chlorine measurements, which often require continuous pH correction, a second input for a pH sensor is available. A hand-held infrared remote controller is required for local configuration and calibration of the transmitter.

MODEL 5081 SMART TWO-WIRE MICROPROCESSOR TRANSMITTER	
CODE	REQUIRED SELECTION
P	pH/ORP
C	Contacting conductivity
T	Toroidal conductivity
A	Amperometric (oxygen, ozone, and chlorine)

CODE	REQUIRED SELECTION
HT	Analog 4-20 mA output with superimposed HART digital signal
FF	Foundation Fieldbus digital output
FI	Foundation Fieldbus digital output with FISCO

CODE	REQUIRED SELECTION
20	Infrared remote controller included
21	Infrared remote controller not included

CODE	AGENCY APPROVALS
60	No approval
67	FM approved intrinsically safe, non-incendive (when used with appropriate sensor and safety barrier), and explosion-proof
69	CSA approved intrinsically safe, non-incendive (when used with appropriate sensor and safety barrier), and explosion-proof
73	ATEX approved intrinsically safe (when used with appropriate sensor and safety barrier)

5081-P-HT-20-67 EXAMPLE

ACCESSORIES

MODEL/PN	DESCRIPTION
515	DC loop power supply (see product data sheet 71-515)
230A	Alarm module (see product data sheet 71-230A)
23572-00	Infrared remote controller (required, one controller can operate any 5081 transmitter)
23820-00	2-in. pipe mounting kit
9241178-00	Stainless steel tag, specify marking
Model 475	To order HART Model 475 Communicator, call Rosemount Measurement at (800) 999-9307
AMS software	To order AMS software, call Rosemount Measurement at (800) 999-9307

Emerson Process Management

2400 Barranca Parkway
Irvine, CA 92606 USA
Tel: (949) 757-8500
Fax: (949) 474-7250

<http://www.rainhome.com>

© Rosemount Analytical Inc. 2011

