

ENDURANCE™ General Purpose Conductivity Sensors

- INITIAL CALIBRATION NOT REQUIRED.
Pre-determined cell constant ensures out-of-the box accuracy.
- VERSATILE MOUNTING CONFIGURATIONS:
screw-in, retractable, and flow-through.
- AVAILABLE WITH VARIOPOL (VP) quick disconnect fitting.

APPLICATIONS

The Model 400/400VP, 401, 402/402VP, and 404 sensors are intended for the determination of electrolytic conductivity in applications ranging from high purity water to clean cooling water. The sensors are ideal for use in clean, non-corrosive liquid having conductivity less than about 20,000 $\mu\text{S}/\text{cm}$. For dirty or corrosive samples or for samples having high conductivity, a toroidal sensor such as the Model 228 or 226 is recommended.

FEATURES

ENDURANCE sensors are contacting conductivity sensors. They are available in cell constants of 0.01, 0.1, 1.0, and 10/cm. The choice of cell constant depends on conductivity. High conductivity samples require larger cell constants. Consult the analyzer Product Data Sheet for recommended ranges and accuracy.

Sensors with 0.01, 0.1 and 1.0/cm cell constants have concentric titanium electrodes separated by a PEEK insulator. EPDM O-rings seal the internal parts of the sensor from the process liquid. Sensors with 10/cm cell constants have graphite electrodes and an epoxy body.

Electrolytic conductivity is a strong function of temperature, and conductivity readings are typically converted to the value at a reference temperature. To measure temperature, ENDURANCE sensors use a platinum RTD. In metal electrode sensors the RTD is inside the inner electrode. In the epoxy body sensor, the RTD is in a titanium thermowell protruding from the end of the sensor.



Model 400 sensors are designed for direct screw-in insertion into process piping using a 3/4-inch MNPT fitting. The Model 400 sensor can also be used in side-stream samples. A 1-inch pipe tee with a 3/4-inch bushing is a suitable flow cell. A 3/4-inch pipe tee can be used with 0.1 and 1.0/cm cells. A transparent plastic flow cell is also available (PN 24091-02).

Model 401 sensor is intended for measuring clean, non-corrosive samples having conductivity between about 500 and 200,000 $\mu\text{S}/\text{cm}$. The sensor has a 10/cm cell constant.

Model 402 sensors are retractable; they can be removed from the process piping without shutting down and draining the line. Maximum retraction pressure is 64 psig (542 kPa abs). The sensor fits through a 1-1/4 inch full-port ball valve. Order the retraction assembly, which includes the ball valve, pipe nipple, packing adapter, and clamp to position the sensor, as an option.

Model 404 sensors combine the conductivity sensor with a flow cell. The design has a small holdup volume, so response to sudden changes in process conductivity and temperature is rapid. Model 404 sensors are available with a PVC or stainless steel body. The stainless steel version can be disassembled for cleaning. The PVC version cannot be taken apart.

Models 400 and 402 sensors are available with Variopol 6 quick disconnect watertight connectors. Wire the interconnecting cable to the analyzer and run the cable to the sensor. The sensor plugs into the cable receptacle. To replace the sensor, simply disconnect the Variopol fitting and plug in a new sensor. There is no need to rewire or rerun cable.

SPECIFICATIONS (Models 400 and 400VP)

Cell constants: 0.01, 0.1, and 1.0/cm

Wetted materials:

Electrodes: titanium
Body: 316 stainless steel
Insulator: PEEK
O-rings: EPDM

Process connection: 3/4 inch MNPT

Temperature: 32 – 221°F (0 – 105°C)

Temperature (option -60): 32 – 392°F (0 – 200°C)

Pressure: 250 psig (1825 kPa abs) maximum

Vacuum: 7.4 psia (51 kPa abs)

Cable length (Model 400 only): 10 ft (3.1 m) standard;
50 ft (15.2 m) optional

SPECIFICATIONS (Model 401)

Cell constant: 10/cm

Wetted materials:

Electrodes: graphite
Connector: PVDF (Kynar®)
Insulator and body: epoxy
O-rings: EPDM
RTD capsule: titanium

Process connection: 3/4 inch MNPT

Temperature: (32 – 212°F) (0 – 100°C).

Pressure: 200 psig (1481 kPa abs) maximum

Cable length: 10 ft (3.1 m) standard; 50 ft (15.2 m)
optional

SPECIFICATIONS (Models 402 and 402VP)

Cell constants: 0.01, 0.1, 1.0, and 10/cm

Wetted materials (0.01, 0.1, and 1.0/cm cells):

Electrodes: titanium
Sensor tube: 316 stainless steel
Insulator: PEEK
O-rings: EPDM
Washer: Neoprene

Wetted materials (10/cm cell):

Electrodes: graphite embedded in epoxy body
Sensor tube: 316 stainless steel
Insulator: Epoxy
O-rings: EPDM
Washer: Neoprene
RTD thermowell: titanium

Process connection: sensor is inserted through
1-1/4 inch NPT full port ball valve

Temperature: 32 – 212°F (0 – 100°C)

Pressure: 200 psig (1481 kPa abs) maximum

Retraction pressure: 64 psig (542 kPa abs) maximum

Cable length (Model 402 only): 10 ft (3.1 m).
For longer cable length, choose option -60
(integral junction box) and order interconnecting
cable separately.

¹Kynar is a registered trademark of Elf Atochem North America, Inc.

SPECIFICATIONS (Model 404)

Cell constants: 0.01 and 0.1/cm

Wetted materials (option -16):

Electrodes: titanium
 Insulator: PEEK
 O-rings: EPDM
 Body: PVC
 Fittings: polyethylene

Wetted materials (option -17):

Electrodes: titanium
 Insulator: PEEK
 O-rings: EPDM
 Body: 303 stainless steel
 Fittings: 316 stainless steel

Process connection (option -16): 3/8 inch barbed tubing connector

Process connection (option -17): compression fitting for 3/8 inch OD tubing. Fittings can be removed to leave 1/4-inch FNPT ports.

Temperature (option -16): 32 – 140°F (0 – 60°C).

Temperature (option -17): 32 – 212°F (0 – 100°C).

Pressure (option -16): 100 psig (791 kPa abs) at 77°F (25°C); 20 psig (239 kPa abs) at 140°F (60°C)

Pressure (option -17): 100 psig (791 kPa abs) maximum

Cable length: 10 ft (3.1 m) standard; 50 ft (15.2 m) optional

SPECIFICATIONS (Flow cell for Model 400/400VP, PN 24091-02)

Wetted Materials:

Body: polycarbonate, polyester
 Fittings: 316 stainless steel
 O-ring: silicone

Process connection: compression fitting for 1/4 inch OD tubing

Temperature: 158°F (70°C) maximum

Pressure: 90 psig (722 kPa abs) maximum

SPECIFICATIONS (Retraction assembly for Model 402/402VP, PN 23765-00/01)

Wetted Materials:

Ball valve: 316 stainless steel with Teflon¹ seals and seat steel
 Nipple: 316 stainless steel
 Packing rings: graphite
 Packing bushing 303 stainless steel
 Retraction body: 316 stainless steel

Process connection: ball valve 1-1/4 inch FNPT; nipple 1-1/4 inch MNPT

Temperature: 32 – 212°F (0 – 100°C).

Pressure: 200 psig (1481 kPa abs) maximum

Retraction pressure: 64 psig (542 kPa abs) maximum

¹ Teflon is a registered trademark of E.I. duPont de Nemours and Co.

SENSOR AND INSTRUMENT SELECTION GUIDELINES

Instrument	Recommended for range for cell constant (µS/cm)		
	0.01/cm	0.1/cm	1.0/cm
1056 and 56	0-200	0.1-2000	1.0-20,000
54eC	0-50	0.1-2000	10-12,000
5081-C	0-50	0.1-500	10-20,000
Xmt-C	0-50	0.1-500	10-20,000
1066	0-200	0.1-2000	10-20,000

WEIGHTS AND SHIPPING WEIGHTS (rounded up to the nearest 1 lb or 0.5 kg)

MODEL	WITH 10 ft. (3.1 m) CABLE		WITH 50 ft. CABLE		WITH JUNCTION BOX	
	Weight	Shipping Weight	Weight	Shipping Weight	Weight	Shipping Weight
400	1 lb (0.5 kg)	2 lb (1.0 kg)	4 lb (2.0 kg)	5 lb (2.5 kg)	3 lb (1.5 kg)	4 lb (2.0 kg)
401-14	1 lb (0.5 kg)	2 lb (1.0 kg)	--	--	--	--
402	3 lb (1.5 kg)	4 lb (2.0 kg)	--	--	4 lb (2.0 kg)	5 lb (2.5 kg)
404-16	2 lb (1.0 kg)	3 lb (1.5 kg)	4 lb (2.0 kg)	5 lb (2.5 kg)	--	--
404-17	4 lb (2.0 kg)	5 lb (2.5 kg)	6 lb (3.0 kg)	7 lb (3.5 kg)	--	--

MODEL	Weight	Shipping Weight
400VP	1 lb (0.5 kg)	2 lb (1.0 kg)
402VP	3 lb (1.5 kg)	4 lb (2.0 kg)

SENSOR DIMENSIONS

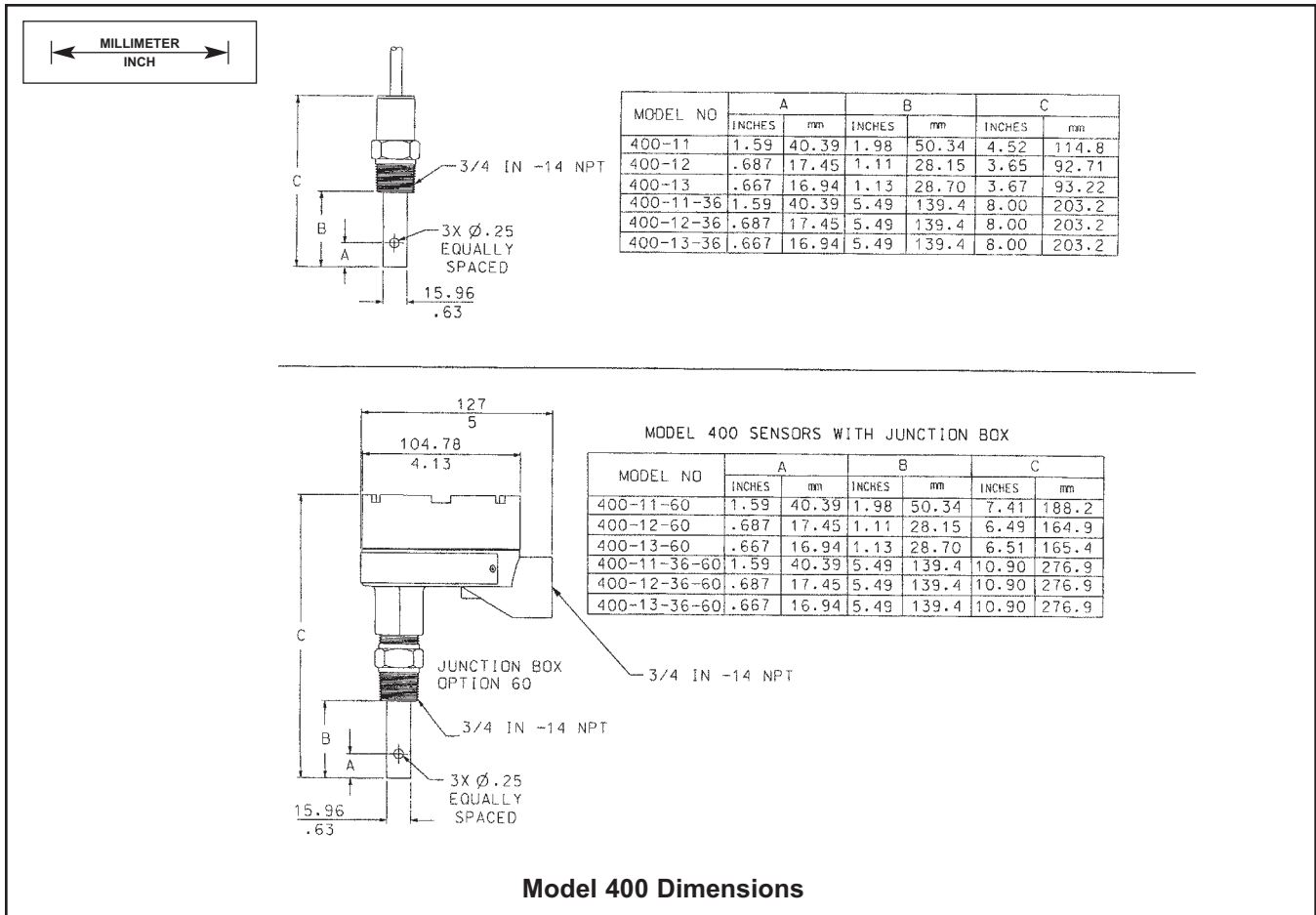

Model 400 Dimensions

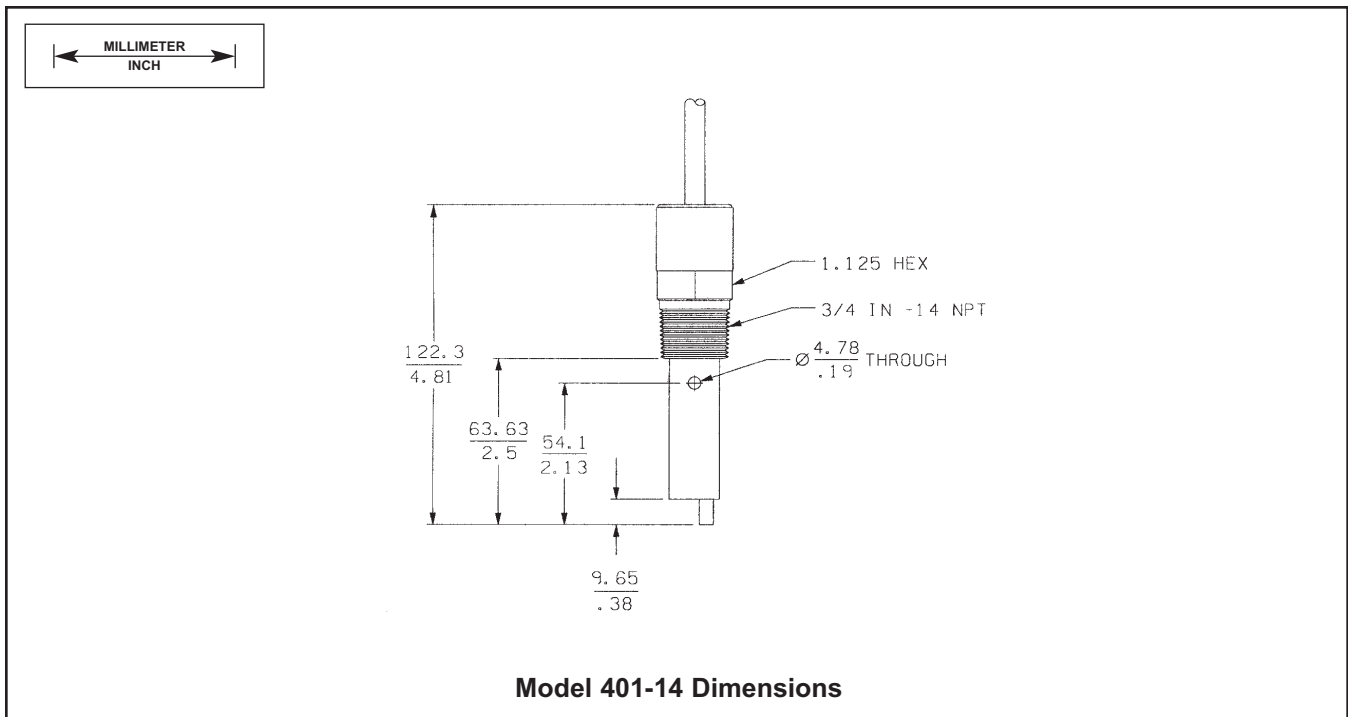

SENSOR DIMENSIONS

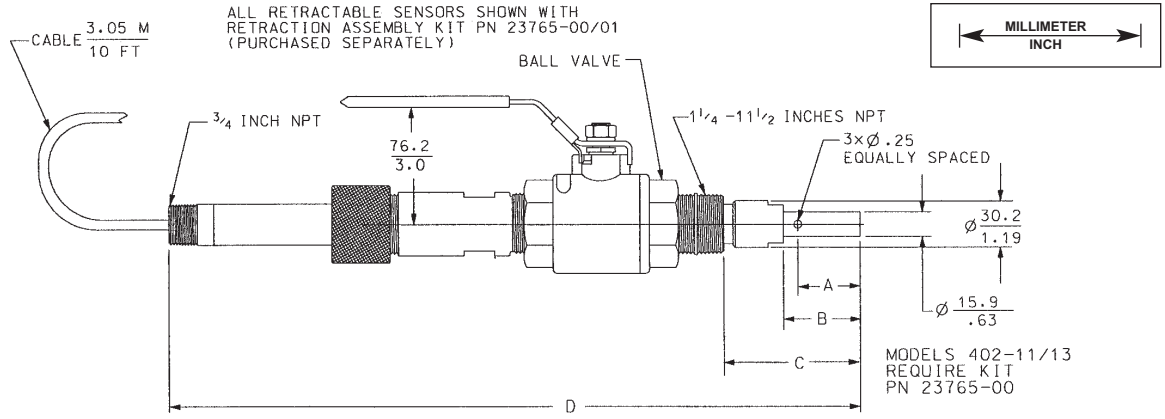

MODEL	RETRACTION ASSY KIT	A		B		C (MIN - MAX)		D	
		INCHES	mm	INCHES	mm	INCHES	mm	INCHES	mm
402-11	23765-00	1.59	40.4	1.98	50.3	3.21-5.34	82-136	18.13	460.5
402-12	23765-00	.687	17.4	1.11	28.2	2.34-4.47	59-114	17.33	440.2
402-13	23765-00	.667	16.9	1.13	28.7	2.36-4.49	60-114	17.33	440.2
402-14	23765-01	2.13	54.1	2.66	67.6	3.89-4.91	99-125	18.83	478.3

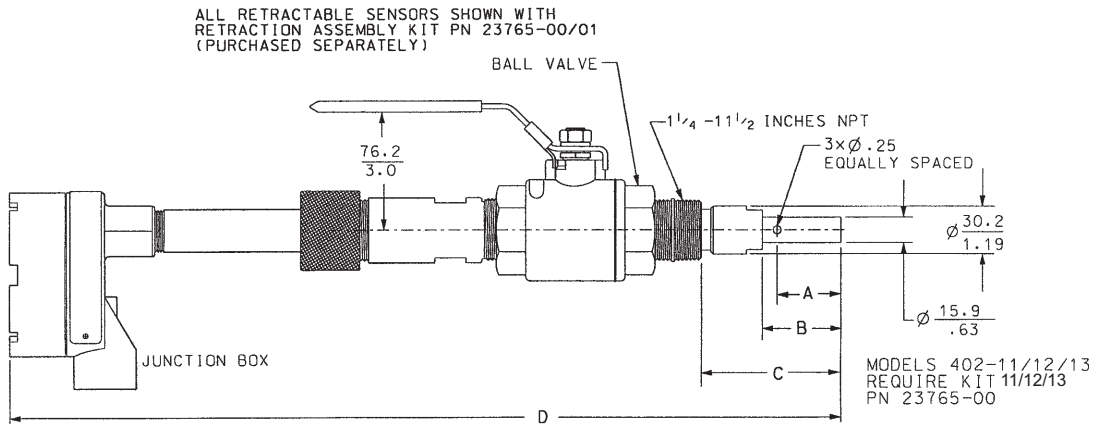
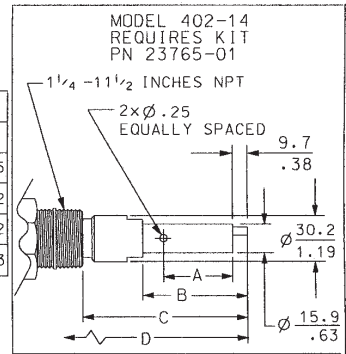

MODEL	RETRACTION ASSY KIT	A		B		C (MIN - MAX)		D	
		INCHES	mm	INCHES	mm	INCHES	mm	INCHES	mm
402-11	23765-00	1.59	40.4	1.98	50.3	3.21-5.34	82-136	21.1	537
402-12	23765-00	.687	17.4	1.11	28.2	2.34-4.47	59-114	20.3	515
402-13	23765-00	.667	16.9	1.13	28.7	2.36-4.49	60-114	20.3	515
402-14	23765-01	2.13	54.1	2.66	67.6	3.89-4.91	99-125	22.1	554

Model 402 Dimensions Shown with Options -31, -32, and -60

SENSOR DIMENSIONS

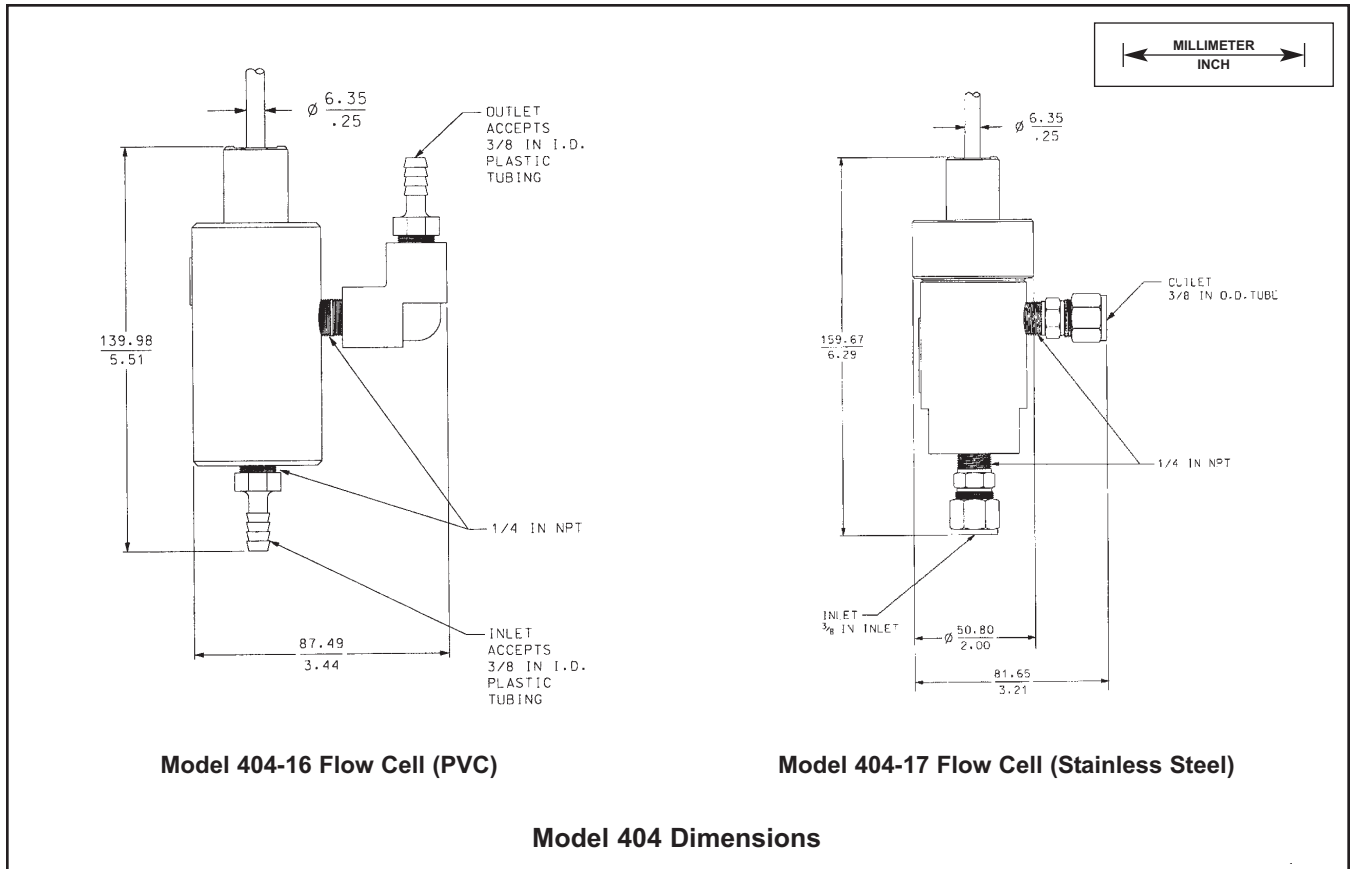

SENSOR DIMENSIONS

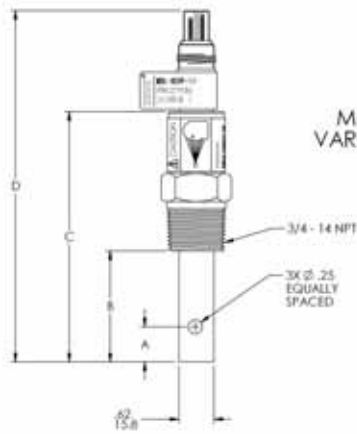

MODEL 400VP SENSOR WITH VARIOPOL (VP 6) CONNECTOR

MODEL NO	A		B		C		D	
	INCHES	MM	INCHES	MM	INCHES	MM	INCHES	MM
400VP-11	1.59	40.4	1.98	50.3	4.43	112.5	6.30	160.0
400VP-12	0.67	17.0	1.10	27.9	3.47	90.4	5.43	137.9
400VP-13	0.67	17.0	1.10	27.9	3.58	90.9	5.45	138.4
400VP-11-36	1.59	40.4	5.48	139.2	7.91	200.9	9.78	248.4
400VP-12-36	0.67	17.0	5.48	139.2	7.91	200.9	9.78	248.4
400VP-13-36	0.67	17.0	5.48	139.2	7.91	200.9	9.78	248.4

Model 400VP Dimensions

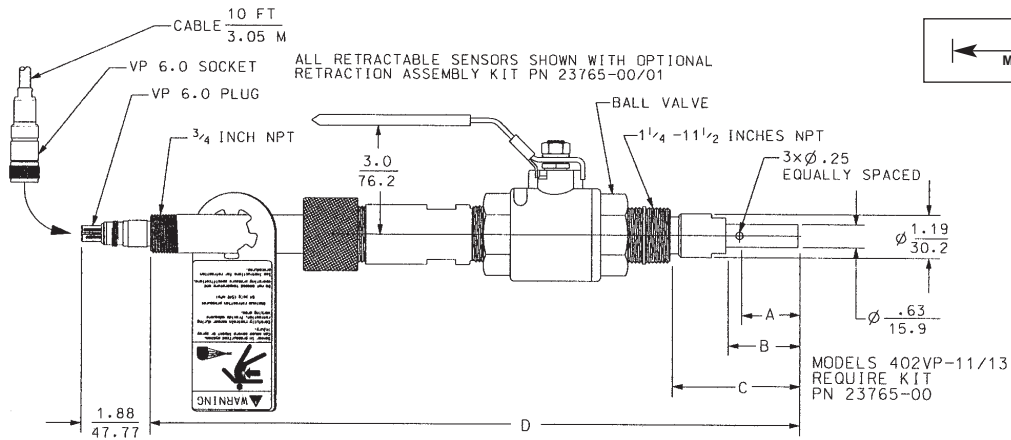

MODEL	RETRACTION ASSY KIT	A		B		C (MIN - MAX)		D	
		INCHES	mm	INCHES	mm	INCHES	mm	INCHES	mm
402-11	23765-00	1.59	40.4	1.98	50.3	3.21-5.34	82-136	18.13	460.5
402-12	23765-00	.687	17.4	1.11	28.2	2.34-4.47	59-114	17.33	440.2
402-13	23765-00	.667	16.9	1.13	28.7	2.36-4.49	60-114	17.33	440.2
402-14	23765-01	2.13	54.1	2.66	67.6	3.89-4.91	99-125	18.83	478.3

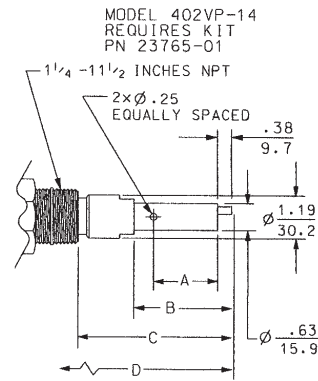

Model 402VP Dimensions

INSTALLATION DETAILS

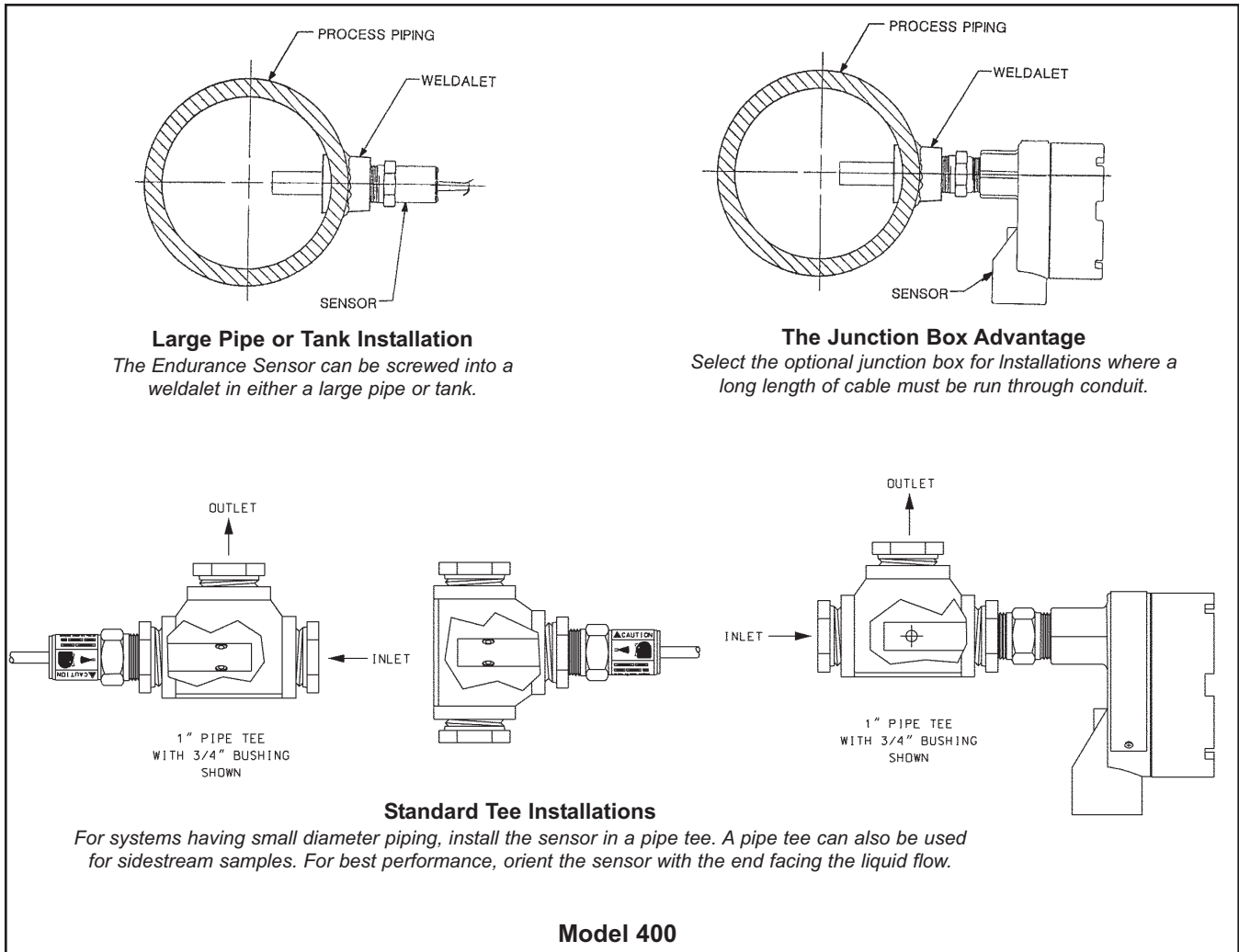
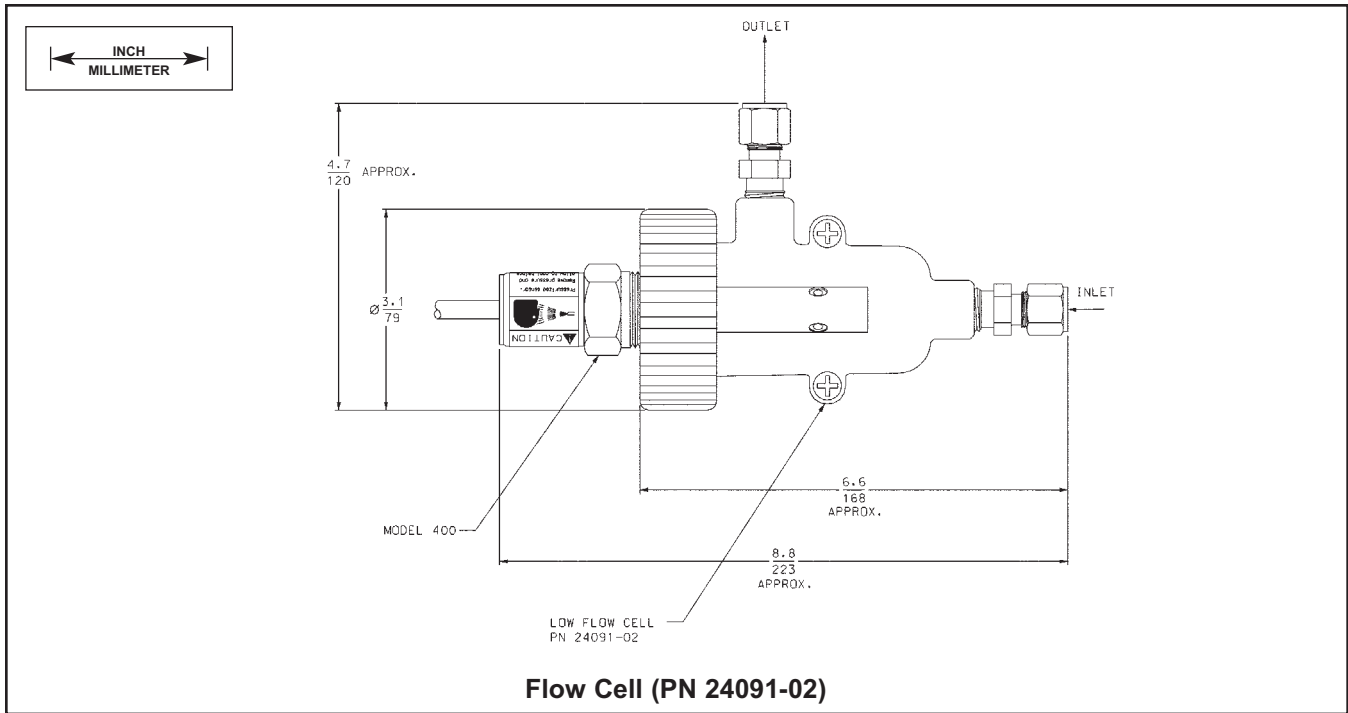

INSTALLATION DETAILS

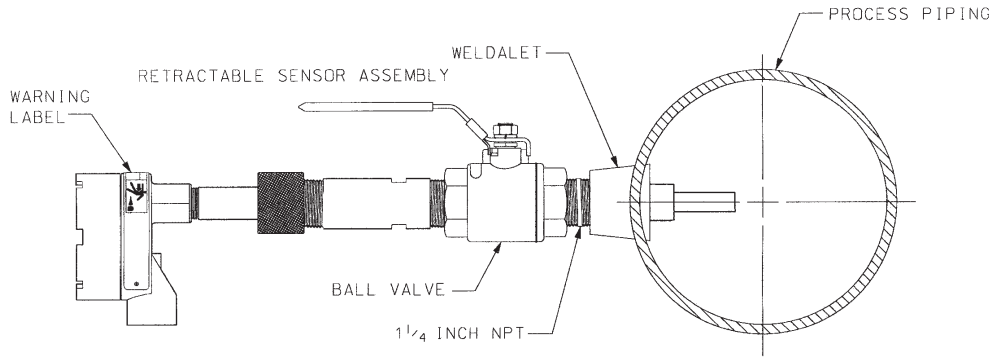

Model 402 Retractable Sensor Installed In a Large Pipe or Tank

The Endurance Retractable Sensor can be attached through a weldolet in either a large pipe or tank.

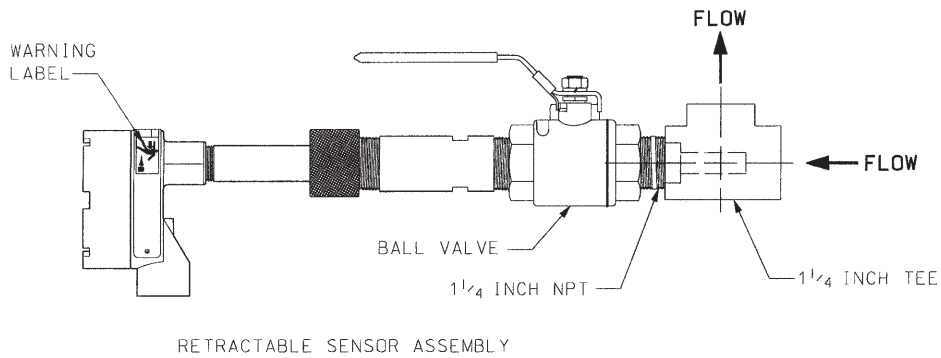

Model 402 Retractable Sensor Installed In a Standard Tee

For best performance, orient the sensor with the end facing the liquid flow.

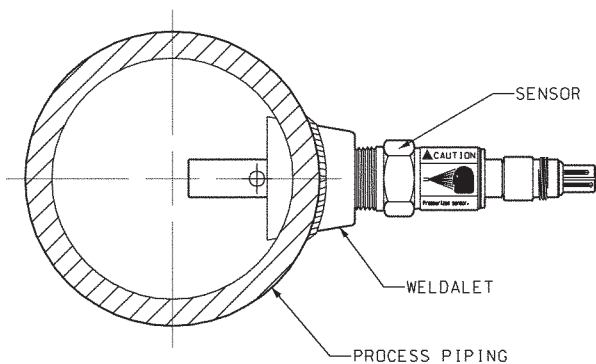

Large Pipe or Tank Installation

The Endurance Sensor can be screwed into a weldolet in either a large pipe or tank.

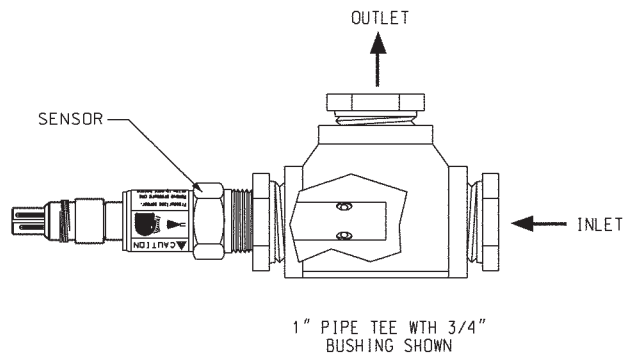

Standard Tee Installations

For systems having small diameter piping, install the sensor in a pipe tee. A pipe tee can also be used for sidestream samples. For best performance, orient the sensor with the end facing the liquid flow.

Model 400VP

INSTALLATION DETAILS

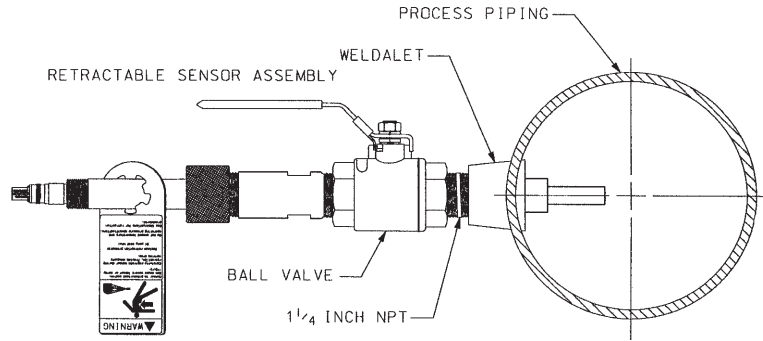

Model 402VP Retractable Sensor Installed in a Large Pipe or Tank

The ENDURANCE Retractable Sensor can be attached through a weldolet in either a large pipe or tank.

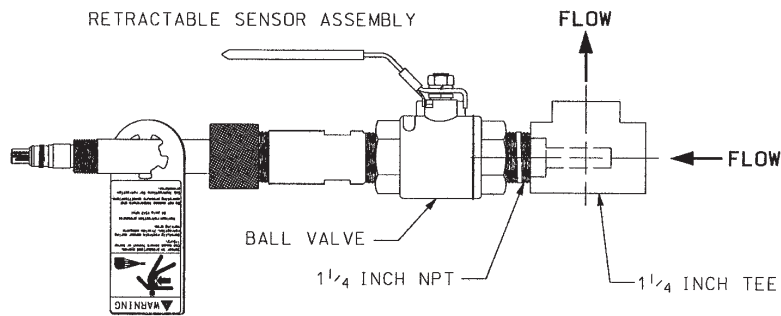

Model 402VP Retractable Sensor Installed in a Standard Tee

For best performance, orient the sensor with the end facing the liquid flow.

Model 402VP

ORDERING INFORMATION

Model 400 Screw-in conductivity sensor with integral cable is intended for the determination of electrolytic conductivity in clean water applications where the sensor can be directly screwed into the process piping or used in a pipe tee or flow cell in a sidestream.

MODEL 400 SCREW-IN CONDUCTIVITY SENSOR	
CODE	Cell Constant (required selection)
11	0.01/cm
12	0.1/cm
13	1.0/cm
CODE	Temperature Measurement
--	Pt 1000 for 1056, 56, 54eC, 5081-C, 6081C, Xmt-C, and 1066-C
CODE	Additional Options (optional selection)
36	Extended insertion length (5.5 in from bottom of threads to tip of sensor)
50	Extended cable length, 50 ft (15.2 m)
60	Integral junction box (required for high temperature applications) (See NOTE.)
400	11 36 EXAMPLE

NOTE: Interconnecting cable between the junction box and analyzer must be purchased as a separate item. See **ACCESSORIES**.

Model 400VP Screw-in conductivity sensor with Variopol connector is intended for the determination of electrolytic conductivity in clean water applications where the sensor can be directly screwed into the process piping or used in a pipe tee or flow cell in a sidestream. **Interconnecting VP cable must be ordered separately and is required for all first time installations. See INTERCONNECTING VP CABLE on page 14.**

MODEL 400VP SCREW-IN CONDUCTIVITY SENSOR	
CODE	Cell Constant (required selection)
11	0.01/cm
12	0.1/cm
13	1.0/cm
CODE	Temperature Measurement
--	Pt 1000 for 1056, 56, 54eC, 5081-C, 6081C, Xmt-C, and 1066-C
CODE	Additional Options (optional selection)
36	Extended insertion length (6 in from inside face of flange to end of sensor)
400VP	11 EXAMPLE

Model 401 Screw-in contacting sensors for high conductivity water are intended for clean, non-corrosive samples having conductivity between about 500 and 200,000 $\mu\text{S}/\text{cm}$.

MODEL 401 SCREW-IN CONDUCTIVITY SENSOR WITH GRAPHITE ELECTRODES	
CODE	Cell Constant (required selection)
14	10/cm, 3/4 inch MNPT process connection
CODE	Temperature Measurement
--	Pt 1000 for 1056, 56, 54eC, 5081-C, 6081C, Xmt-C, and 1066-C
401	14 EXAMPLE

Model 402 Retractable conductivity sensor with integral cable or junction box is intended for the determination of electrolytic conductivity in clean water applications where the ability to remove the sensor without shutting down the process or draining the line or tank is required.

MODEL 402 RETRACTABLE CONDUCTIVITY SENSOR	
CODE	Cell Constant (required selection)
11	0.01/cm
12	0.1/cm
13	1.0/cm
14	10/cm
CODE	Temperature Measurement
--	Pt 1000 for 1056, 56, 54eC, 5081-C, 6081C, Xmt-C, and 1066-C
CODE	Additional Options (optional selection)
31	Retraction assembly (complete) for options -11, -12, and -13
32	Retraction assembly (complete) for option -14 only
60	Integral junction box (See NOTE.)
61	Sensor cable terminated for use with sensor junction box (See NOTE.)
402	11 32 60 61 EXAMPLE

NOTE: Interconnecting cable between the junction box and analyzer must be purchased as a separate item. See **ACCESSORIES**.

Model 402VP Retractable conductivity sensor with VP connector is intended for the determination of electrolytic conductivity in clean water applications where the ability to remove the sensor without shutting down the process or draining the line or tank is required. **Interconnecting VP cable must be ordered separately and is required for all first time installations. See INTERCONNECTING VP CABLE on page 14.**

MODEL	
402VP	RETRACTABLE CONDUCTIVITY SENSOR
CODE	Cell Constant (required selection)
11	0.01/cm
12	0.1/cm
13	1.0/cm
14	10/cm
CODE	Temperature Measurement
--	Pt 1000 for 1056, 56, 54eC, 5081-C, 6081C, Xmt-C, and 1066-C
CODE	Additional Options (optional selection)
31	Retraction assembly (complete) for options -11, -12, and -13
32	Retraction assembly (complete) for option -14 only
402VP	12 31
EXAMPLE	

Model 404 Flow through conductivity sensor is intended for the determination of electrolytic conductivity in clean water applications where rapid response to changes in conductivity or temperature is needed. The sensor must be used in a sidestream sample.

MODEL	
404	FLOW THROUGH CONDUCTIVITY SENSOR
CODE	Cell Constant (required selection)
11	0.01/cm
12	0.1/cm
CODE	Flow Cell body (required selection)
16	PVC
17	Stainless steel
CODE	Temperature Measurement
--	Pt 1000 for 1056, 56, 54eC, 5081-C, 6081C, Xmt-C, and 1066-C
CODE	Additional Options (optional selection)
50	Extended cable length, 50 ft (15.2 m)
404	11 16
EXAMPLE	

ACCESSORIES for all models

Part Number	Description	Weight	Shipping Weight
23550-00	Junction box for remote cable connection	8 lb (4.0 kg)	9 lb (4.5 kg)
9200275	Connecting cable, unterminated, specify length	0.6 lb/10ft (1 kg/10 m)	Add 1 lb (0.5 kg)
23747-00	Connecting cable, terminated, specify length	0.6 lb/10ft (1 kg/10 m)	Add 1 lb (0.5 kg)
05010781899	Conductivity standard SS-6, 200 uS/cm, 32 oz (0.95 L)	3 lb (1.5 kg)	4 lb (2.0 kg)
05010797875	Conductivity standard SS-6A, 200 uS/cm, 1 gal (3.78 L)	9 lb (4.5 kg)	10 lb (4.5 kg)
05010782468	Conductivity standard SS-5, 1000 uS/cm, 32 oz (0.95 L)	3 lb (1.5 kg)	4 lb (2.0 kg)
05010783002	Conductivity standard SS-5A, 1000 uS/cm, 1 gal (3.78 L)	9 lb (4.5 kg)	10 lb (4.5 kg)
05000705464	Conductivity standard SS-1, 1409 uS/cm, 32 oz (0.95 L)	3 lb (1.5 kg)	4 lb (2.0 kg)
05000709672	Conductivity standard SS-1A, 1409 uS/cm, 1 gal (3.78 L)	9 lb (4.5 kg)	10 lb (4.5 kg)
05010782147	Conductivity standard SS-7, 5000 uS/cm, 32 oz (0.95 L)	3 lb (1.5 kg)	4 lb (2.0 kg)
05010782026	Conductivity standard SS-7A, 5000 uS/cm, 1 gal (3.78 L)	9 lb (4.5 kg)	10 lb (4.5 kg)

ACCESSORIES for Model 400 and 400VP

Part Number	Description	Weight	Shipping Weight
24091-02	Flow cell, accepts sensor with 3/4-inch MNPT	1 lb (0.5 kg)	2 lb (1.0 kg)

ACCESSORIES for Model 402 and 402VP

Part Number	Description	Weight	Shipping Weight
23765-00	Retraction assembly kit (complete) for use with options -11, -12, and -13	8 lb (4.0 kg)	9 lb (4.5 kg)
23765-01	Retraction assembly kit (complete) for use with option -14	8 lb (4.0 kg)	9 lb (4.5 kg)
23796-00	Packing adapter subassembly for options -11, -12, and -13 (excludes ball valve and nipple, see figure on page 5 and 9).	4 lb (2 kg)	5 lb (2.5 kg)
23796-01	Packing adapter subassembly for options -11, -12, and -13 (excludes ball valve and nipple, see figure on page 5 and 9).	4 lb (2 kg)	5 lb (2.5 kg)
9340078	1 1/4 inch NPT full port ball valve	4 lb (2 kg)	5 lb (2.5 kg)
9160410	Packing rings for use packing adapter subassembly (PN 23796-00/01) and retraction assembly kit (PN 23765-00/01)	1 lb (0.5 kg)	2 lb (1.0 kg)

INTERCONNECTING VP CABLE for 400VP and 402VP sensor

Part Number	Description	Weight	Shipping Weight
23747-06	Interconnecting cable, VP 6, 2.5 ft (0.8 m)	1 lb (0.5 kg)	Add 1 lb (0.5 kg)
23747-04	Interconnecting cable, VP 6, 4 ft (1.2m)	1 lb (0.5 kg)	Add 1 lb (0.5 kg)
23747-02	Interconnecting cable, VP 6, 10 ft (3.0 m)	1 lb (0.5 kg)	Add 1 lb (0.5 kg)
23747-07	Interconnecting cable, VP 6, 15 ft (4.6 m)	2 lb (1.0 kg)	Add 1 lb (0.5 kg)
23747-08	Interconnecting cable, VP 6, 20 ft (6.1 m)	2 lb (1.0 kg)	Add 1 lb (0.5 kg)
23747-09	Interconnecting cable, VP 6, 25 ft (7.6 m)	2 lb (1.0 kg)	Add 1 lb (0.5 kg)
23747-10	Interconnecting cable, VP 6, 30 ft (9.1 m)	2 lb (1.0 kg)	Add 1 lb (0.5 kg)
23747-03	Interconnecting cable, VP 6, 50 ft (15.2 m)	4 lb (2.0 kg)	Add 1 lb (0.5 kg)
23747-11	Interconnecting cable, VP 6, 100 ft (30.5 m)	8 lb (4.0 kg)	Add 1 lb (0.5 kg)

ENGINEERING SPECIFICATIONS

Engineering Specification for 400 and 400VP sensor (Cell constants 0.01, 0.1, and 1.0/cm)

1. The sensor shall be suitable for the determination of electrolytic conductivity in clean, non-corrosive samples.
2. The sensor shall have a 3/4- inch MNPT fitting for direct insertion into pipes or tees. A clear plastic flow cell shall also be available for side-stream samples.
3. The sensor shall incorporate titanium electrodes and a PEEK insulator.
4. The sensor shall have an integral platinum RTD for temperature measurement.
5. The sensor shall be available with either integral cable or a Variopol quick disconnect fitting.
6. The maximum temperature for the sensor shall be 221°F (105°C) at 250 psig (1825 kPa abs). A high temperature option that can be used at 392°F (200°C) shall also be available.
7. The sensor shall be suitable for vacuum service as low as 7.4 psia (51 kPa abs).
8. The sensor shall be Rosemount Analytical Model 400 (integral cable) or 400VP (Variopol fitting) or approved equal.

Engineering Specification for 402 and 402VP sensor (Cell constants 0.01, 0.1, and 1.0/cm)

1. The sensor shall be suitable for the determination of electrolytic conductivity in clean, non-corrosive samples where the ability to remove the sensor from the process piping or tank without shutting down or draining lines or equipment is desired.
2. The sensor shall be supplied with a retraction assembly and full port ball valve. The ball valve shall be connected to the piping or tank using a 1-1/4 inch close nipple.
3. The sensor shall incorporate titanium electrodes and a PEEK insulator.
4. The sensor shall have an integral platinum RTD for temperature measurement.
5. The sensor insertion tube shall be 316 stainless steel.

6. The ball valve shall be 316 stainless steel with Teflon seals and seats.
7. The retraction body shall be 316 stainless steel and shall use three graphite packing rings to seal the sensor tube.
8. The maximum temperature for the sensor shall be 212°F (100°C) at 200 psig (1481 kPa abs).
9. The maximum retraction pressure shall be 64 psig (542 kPa abs).
10. The sensor shall be available with integral cable, integral junction box, or a Variopol quick disconnect fitting.
11. The sensor shall be Rosemount Analytical Model 402 (integral cable) or 402VP (Variopol fitting) or approved equal.

Engineering Specification for 404 Sensor (0.01 and 0.1/cm cell constants)

1. The sensor shall be suitable for the determination of electrolytic conductivity in clean, non-corrosive sidestream samples where rapid response to changes in conductivity or temperature is needed.
2. The sensor shall incorporate titanium electrodes and a PEEK insulator.
3. The sensor shall have an integral platinum RTD for temperature measurement.
4. The sensor shall be available with either a PVC or stainless steel body flow cell
5. The PVC body sensor shall have 3/8-inch barbed tubing connectors.
6. The stainless steel body sensor shall have compression fittings for 3/8-inch OD tubing. The compression fittings shall be removable to leave 1/4-inch FNPT ports.
7. The maximum temperature for the PVC body sensor shall be 140°F (60°C) at 20 psig (239 kPa abs).
8. The maximum temperature for the stainless steel body sensor shall be 212°F (100°C) at 100 psig (791 kPa abs).
9. The sensor shall be Rosemount Analytical Model 404 or approved equal.

COMPATIBLE ANALYZERS AND TRANSMITTERS

The Model 1056 Dual Input Analyzer can be used with any ENDURANCE family conductivity sensor to measure electrolytic conductivity in a variety of applications. The Model 1056 can be set up as either a dual input conductivity analyzer, or the second input can be connected to a pH, ORP, chlorine, oxygen, ozone, or turbidity sensor. The analyzer has two fully programmable analog outputs. Four fully programmable alarm relays are available as an option. The high contrast display shows measurement results in large, easy-to-read digits. Menu screens for programming are simple and intuitive. Plain language prompts (in seven languages) guide the user. The analyzer continuously monitors itself and the sensor for faults and alerts the user when it detects a problem. HART and Profibus digital communications are optional. HART allows the user to communicate with the analyzer through AMS (Asset Management Solutions) from a host anywhere in the plant.



The Model 5081-C Transmitter can be used with any ENDURANCE family conductivity sensor to measure electrolytic conductivity in a variety of applications, particularly where a robust, explosion-proof instrument enclosure and loop power are needed. The conductivity reading is shown in large numerals in the top line of a two-line, seven-segment display. Local communication with the 5081-C is through a handheld infrared remote controller. Two digital communication protocols are available: HART and Foundation Fieldbus. Digital communications allows the user to communicate with the transmitter through AMS (Asset Management Solutions) from a host anywhere in the plant.



The Model 56 Analyzer can be used with any ENDURANCE family conductivity sensor to measure electrolytic conductivity in a variety of applications. The Model 56 can be set up as either a dual input conductivity analyzer, or the second input can be connected to a pH, ORP, chlorine, oxygen, ozone, or turbidity sensor. The analyzer has four fully programmable analog outputs and four fully programmable alarm relays, including PID and TPC control. The high contrast, full color display shows measurement results in large, easy-to-read digits. Menu screens for programming and calibration are simple and intuitive. Information screens, offering detailed explanation of programming features and calibration methods as well as troubleshooting assistance, are available at the touch of a button. An event and data logger and a dual graphical display are also standard. HART and Profibus DP digital communication are optional.



The Model Xmt-C Transmitter can be used with any ENDURANCE family conductivity sensor to measure electrolytic conductivity in a variety of applications, particularly in application where loop power is needed. The Xmt-C has a two-line display that can be configured to meet user requirements. Menu screens (in six languages) for configuring and calibrating are simple and intuitive. Two digital communication protocols are available: HART and Foundation Fieldbus. Digital communications allows the user to communicate with the transmitter through AMS (Asset Management Solutions) from a host anywhere in the plant.



All Rosemount Analytical Conductivity Instruments feature automatic temperature corrections for high purity water and cation conductivity. Programmable percent change per °C temperature correction is also available.



*The right people,
the right answers,
right now.*

ROSEMOUNT ANALYTICAL
CUSTOMER SUPPORT CENTER
1-800-854-8257



ON-LINE ORDERING NOW AVAILABLE ON OUR WEB SITE
<http://www.raihome.com>

Specifications subject to change without notice.



Credit Cards for U.S. Purchases Only.



Emerson Process Management

2400 Barranca Parkway
Irvine, CA 92606 USA
Tel: (949) 757-8500
Fax: (949) 474-7250

<http://www.raihome.com>