

FOUNDATION[®] Fieldbus Two-Wire Toroidal Conductivity Transmitter



For additional information, please refer to our website at
www.emersonprocess.com/raihome/liquid/.

ESSENTIAL INSTRUCTIONS

READ THIS PAGE BEFORE PROCEEDING!

Your purchase from Rosemount Analytical, Inc. has resulted in one of the finest instruments available for your particular application. These instruments have been designed, and tested to meet many national and international standards. Experience indicates that its performance is directly related to the quality of the installation and knowledge of the user in operating and maintaining the instrument. To ensure their continued operation to the design specifications, personnel should read this manual thoroughly before proceeding with installation, commissioning, operation, and maintenance of this instrument. If this equipment is used in a manner not specified by the manufacturer, the protection provided by it against hazards may be impaired.

- Failure to follow the proper instructions may cause any one of the following situations to occur: Loss of life; personal injury; property damage; damage to this instrument; and warranty invalidation.
- Ensure that you have received the correct model and options from your purchase order. Verify that this manual covers your model and options. If not, call 1-800-854-8257 or 949-757-8500 to request correct manual.
- For clarification of instructions, contact your Rosemount representative.
- Follow all warnings, cautions, and instructions marked on and supplied with the product.
- Use only qualified personnel to install, operate, update, program and maintain the product.
- Educate your personnel in the proper installation, operation, and maintenance of the product.
- Install equipment as specified in the Installation section of this manual. Follow appropriate local and national codes. Only connect the product to electrical and pressure sources specified in this manual.
- Use only factory documented components for repair. Tampering or unauthorized substitution of parts and procedures can affect the performance and cause unsafe operation of your process.
- All equipment doors must be closed and protective covers must be in place unless qualified personnel are performing maintenance.
- If this equipment is used in a manner not specified by the manufacturer, the protection provided by it against hazards may be impaired.

⚠ WARNING

EXPLOSION HAZARD
DO NOT OPEN WHILE CIRCUIT IS LIVE
DO NOT RUB OR CLEAN WITH SOLVENTS
9241589-00/A

SPECIFICATIONS - GENERAL

Case: ABS (panel mount), polycarbonate (pipe/surface ount). Both versions are NEMA 4X/CSA 4 (IP65).

Dimensions

Panel (code -10): 6.10 x 6.10 x 3.72 in. (155 x 155 x 94.5 mm)

Surface/Pipe (code -11): 6.23 x 6.23 x 3.23 in. (158 x 158 x 82 mm)

Conduit openings: Accepts PG13.5 or 1/2 in. conduit fittings

Ambient Temperature: 32 to 122°F (0 to 50°C). Some degradation of display above 50°C.

Storage Temperature: -4 to 158°F (-20 to 70°C)

Relative Humidity: 10 to 90% (non-condensing)

Weight/Shipping Weight: 3 lb/4 lb (1.5 kg/2 kg)

Display: Two line, 16-character display. Character height: 4.8 mm; first line shows process variable, second line shows process temperature and output current. Fault and warning messages, when triggered, alternate with temperature and output readings.

During calibration and programming, messages, prompts, and editable values appear on the two-line display.

Temperature resolution: 0.1°C ($\leq 99.9^\circ\text{C}$); 1°C ($\geq 100^\circ\text{C}$)

RFI/EMI: EN-61326 

Power & Load Requirements: A power supply voltage of 9-32 Vdc at 13 mA is required.

Intrinsic Safety:



Class I, II, III, Div. 1
Groups A-G
T4 Tamb = 50°C



Class I, II, III, Div. 1
Groups A-G
T4 Tamb = 50°C

ATEX

 1180



II 1 G
Baseefa04ATEX0215X
EEx ia IIC T4
Tamb = 0°C to 50°C

Non-Incendive:



Class I, Div. 2, Groups A-D
Dust Ignition Proof
Class II & III, Div. 1, Groups E-G
NEMA 4/4X Enclosure



Class I, Div. 2, Groups A-D
Dust Ignition Proof
Class II & III, Div. 1, Groups E-G
NEMA 4/4X Enclosure
T4 Tamb = 50°C

FUNCTIONAL SPECIFICATIONS

Automatic Temperature Compensation:

3-wire Pt 100 RTD or Pt 1000 RTD

Conductivity: 0 to 200°C (32 to 392°F)

% Concentration: 0 to 100°C (32 to 212°F)

Diagnostics: The internal diagnostics can detect:

Calibration Error	ROM Failure
Temperature Slope Error	Zero Error
High Temperature Warning	CPU Failure
Low Temperature Warning	Input Warning

Once one of the above is diagnosed, the LCD will display a message describing the problem.

Digital Communications:

HART: PV, SV, and TV assignable to measurement (conductivity, resistivity, or concentration), temperature, and raw conductivity. Raw conductivity is measured conductivity before temperature correction.

Fieldbus: Three AI blocks assignable to measurement (conductivity, resistivity, or concentration), temperature, and raw conductivity. Raw conductivity is measured conductivity before temperature correction. Execution time 75 msec. One PID block; execution time 150 msec. Device type: 4084. Device revision: 1. Certified to ITK 4.5.

TRANSMITTER SPECIFICATIONS @ 25°C

Measured Range: 50 to 2,000,000 µS/cm (see chart)

Repeatability: ± 0.25% of reading

Temperature Accuracy:

± 0.2°C between 0 and 50°C

± 0.5°C above 50°C

(excludes inaccuracies in sensor)

Temperature Slope Adjustment: 0-5%/° C

% Concentration Ranges:

Sodium Hydroxide: 0 to 12%

Hydrochloric Acid: 0 to 15%

Sulfuric Acid: 0 to 25% and 96.0 to 99.7%

Sodium Chloride: 0 to 20%

Ambient Temperature Coefficient:

± 0.1% of reading ±2µS/cm per °C

Maximum Cable Length: 100 ft (30 m)

LOOP SPECIFICATIONS

Loop Accuracy: With a standard Model 228 or 225 sensor with 20' cable, following a single point calibration, laboratory accuracy at 25°C can be as good as ±2% of reading and ±50 µS/cm.

For optimum performance, standardize the sensor in the process at the conductivity and temperature of interest.

Results under real process conditions, at different temperatures, or using other sensors may differ from above.

Calibration: Calibrate against previously calibrated standard sensor and analyzer, or calibrate against solution of known conductivity.

RECOMMENDED SENSORS:

Model 222	Flow-Through
Model 225	Clean-In-Place (CIP)
Model 226	Submersion/Insertion
Model 228	Submersion/Insertion/Retractable
Model 242	Flow-Through
Model 245	Sanitary Flow-Through
Model 247	Submersion/Flow-Tee

RECOMMENDED RANGES FOR TOROIDAL SENSORS							
Conductivity Sensor Model Number	226	228	225	222 (1in.)	222 (2 in.)	242/245	247
Nominal Cell Constant	1.0	3.0	3.0	6.0	4.0	*	3.5
Minimum Conductivity (µS/cm)	50	200	200	500	500	100*	500
Maximum Conductivity (µS/cm)	1,000,000	2,000,000	2,000,000	2,000,000	2,000,000	2,000,000*	1,000,000

* Model 242/245 values depend on sensor configuration and wiring.

Values shown are for 25°C conductivity with a temperature slope of 2% per degree C. The maximum range value will be lower for solutions with a higher temperature slope. Minimum conductivity depends on sensor.

QUICK START GUIDE

FOR MODEL SOLU COMP Xmt-T-FF/FI TRANSMITTER

1. Refer to page 5 for installation instructions.
2. Wire conductivity sensor to the transmitter. See page 9. Refer to the sensor instruction sheet for details.
3. Once connections are secure and verified, apply power to the transmitter.
4. When the transmitter is powered up for the first time, **Quick Start** screens appear. Using **Quick Start** is easy.
 - a. A blinking field shows the position of the cursor.
 - b. Use the \leftarrow or \rightarrow key to move the cursor left or right. Use the \uparrow or \downarrow key to move the cursor up or down or to increase or decrease the value of a digit. Use the \uparrow or \downarrow key to move the decimal point.
 - c. Press ENTER to store a setting. Press EXIT to leave without storing changes. Pressing EXIT also returns the display to the previous screen.

```
English      Français
Español     >>
```

```
Measure?    Cond
TDS         Custom  %Conc
```

```
Cell Constant?
3.0000/cm
```

```
S1 %Conc?   NaCl
NaOH        H2SO4     HCl
```

```
Custom Config
Enter Data Pts
```

```
Temperature in?
°C             °F
```

5. Choose the desired language. Select **>>** to show more choices.
6. Choose measurement: **Cond**, **TDS**, **Custom**, or **%Conc**.
7. Enter the cell constant.
8. This screen appears only if you selected **%Conc** in step 6. Choose **NaCl**, **NaOH**, **H2SO4**, or **HCl**. If you chose **H2SO4**, select **0-25%** or **96-999.7%**.
9. If you selected **Custom**, you must enter the appropriate conductivity and concentration data points. From the main display, press **MENU**. Choose **Program** followed by **Measurement** and **Custom**. The screen shown at left appears. Choose **Custom Config**. Follow the prompts and enter the display units, the number of data points, the reference temperature, and the temperature coefficient (slope). Once the analyzer has been configured, press **EXIT** to return to the screen at the left. Select **Enter Data Pts** and enter the concentration and conductivity data points. For a guide to the program menu, see the menu tree on page 10.
10. Choose temperature units: **°C** or **°F**.
11. To change output settings, to scale the 4-20 mA output, to change measurement-related settings from the default values, and to set security codes, press **MENU**. Select **Program** and follow the prompts. Refer to the menu tree on page 10.
12. To return the transmitter to default settings, choose **ResetAnalyzer** in the Program menu.

UNPACKING AND INSPECTION

Inspect the shipping container. If it is damaged, contact the shipper immediately for instructions. Save the box. If there is no apparent damage, unpack the container. Be sure all items shown on the packing list are present. If items are missing, notify Emerson Process Management immediately.

INSTALLATION

1. Although the transmitter is suitable for outdoor use, do not install it in direct sunlight or in areas of extreme temperatures.
2. Install the transmitter in an area where vibrations and electromagnetic and radio frequency interference are minimized or absent.
3. Keep the transmitter and sensor wiring at least one foot from high voltage conductors. Be sure there is easy access to the transmitter.
4. The transmitter is suitable for panel (Figure 1), pipe (Figure 2), or surface (Figure 3) mounting.
5. The transmitter case has two 1/2-inch (PG13.5) conduit openings and either one or four 1/2-inch knockouts. The panel mount Xmt-T-FF/FI has four knockouts. The pipe/surface mount transmitter has one knockout. One conduit opening is for the power/output cable; the other opening is for the sensor cable. The knockout should be removed only if a second sensor is required, i.e., if free chlorine with continuous pH correction is being measured.
6. Use weathertight cable glands to keep moisture out to the transmitter. If conduit is used, plug and seal the connections at the transmitter housing to prevent moisture from getting inside the instrument.
7. To reduce the likelihood of stress on wiring connections, do not remove the hinged front panel (-11 models) from the base during wiring installation. Allow sufficient wire leads to avoid stress on conductors.

The figure to the right shows how to remove the knockouts. The knockout grooves are on the outside of the case. Place the screwdriver blade on the inside of the case and align it approximately along the groove. Rap the screwdriver sharply with a hammer until the groove cracks. Move the screwdriver to an uncracked portion of the groove and continue the process until the knockout falls out. Use a small knife blade to remove the flash from the inside of the hole.

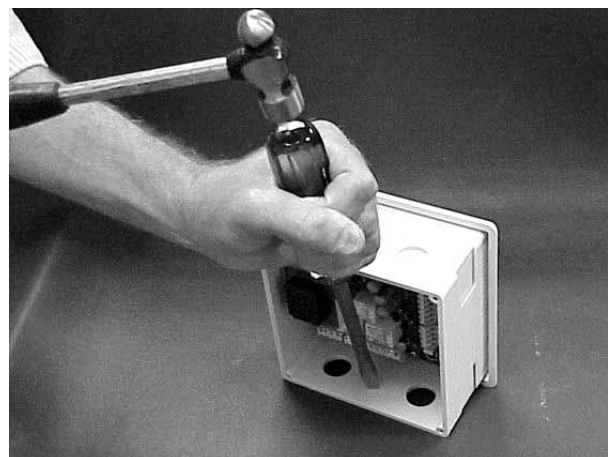

Removing the Knockouts

Panel Mounting.

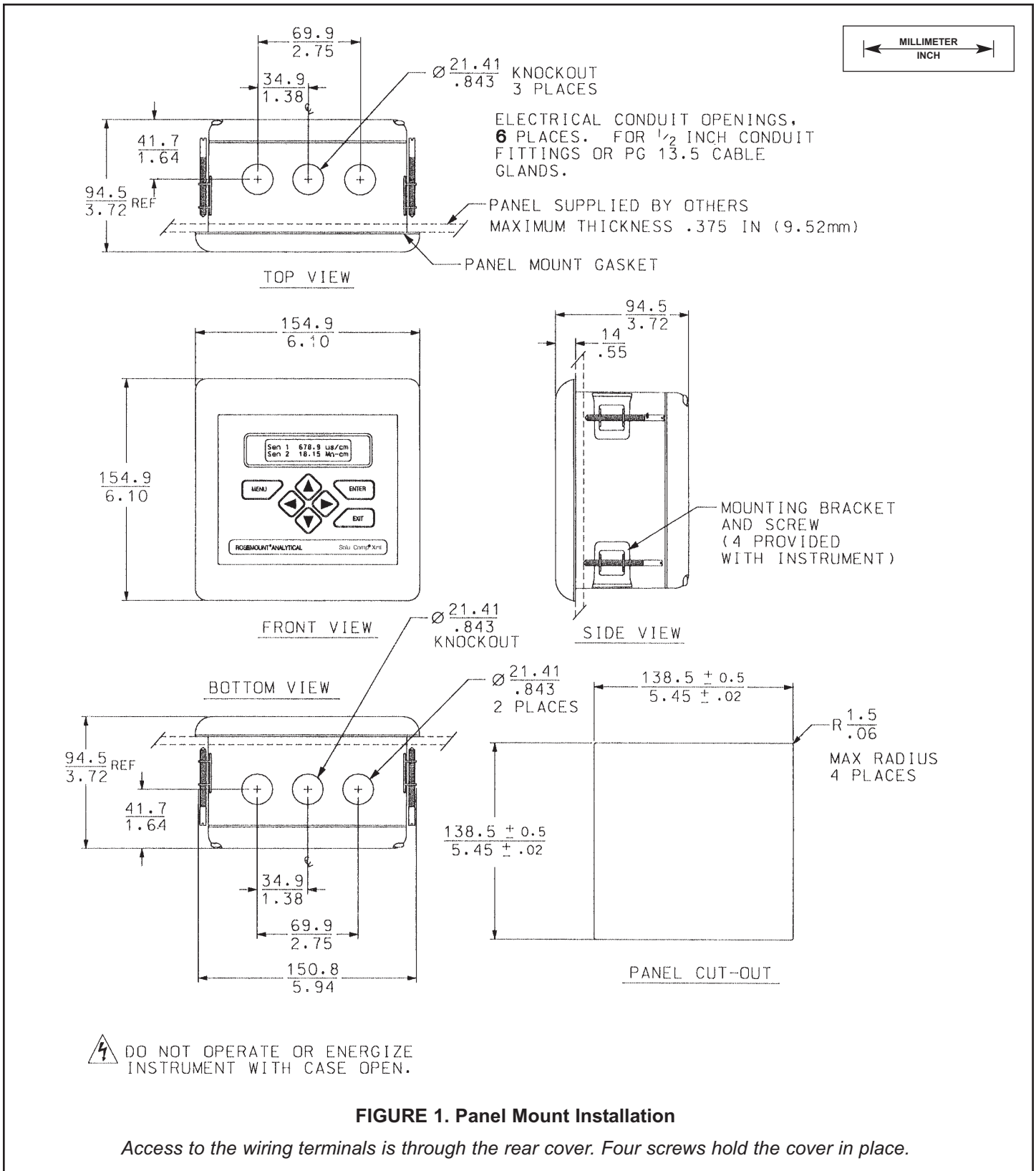

Pipe Mounting.

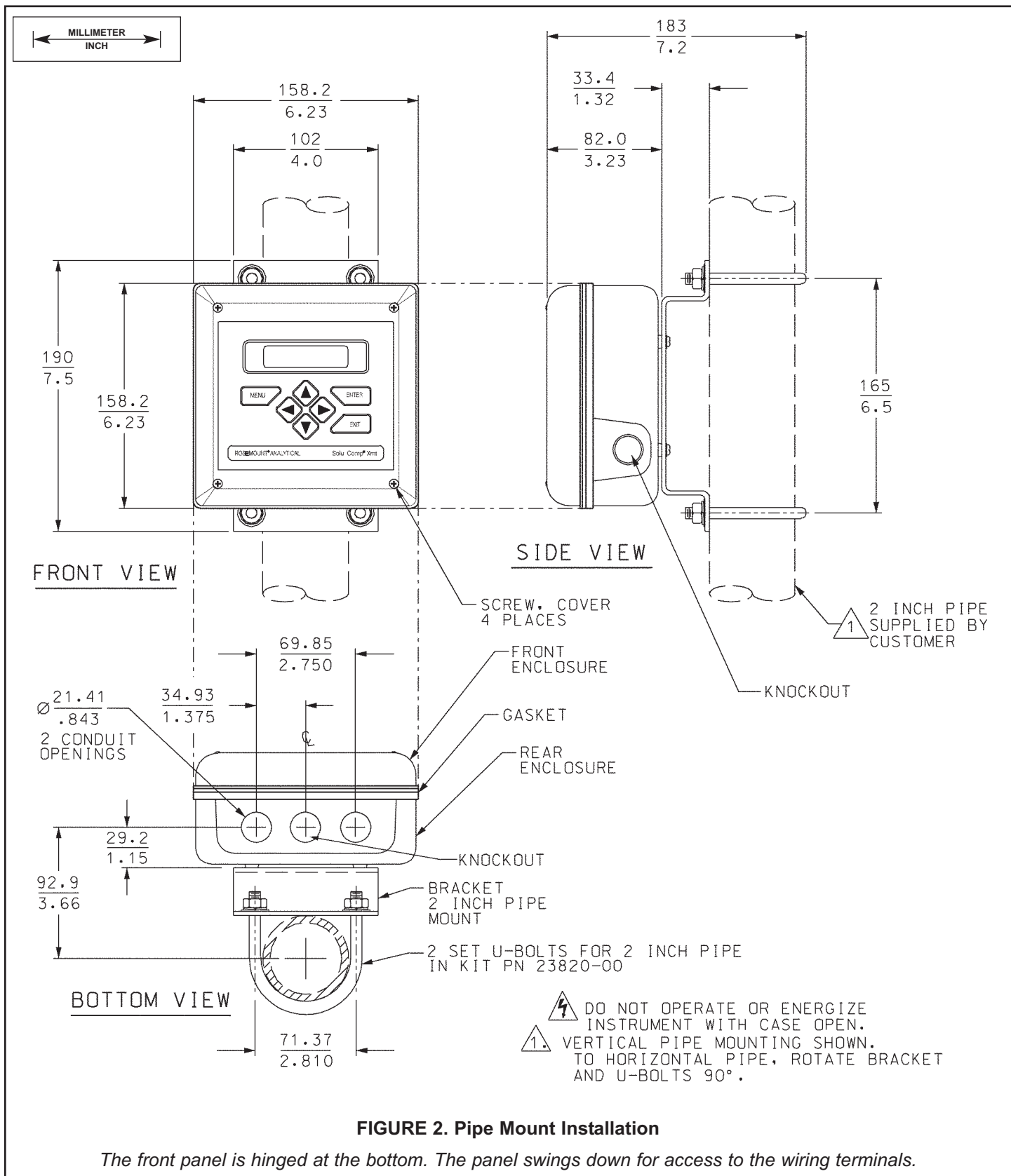

Surface Mounting.

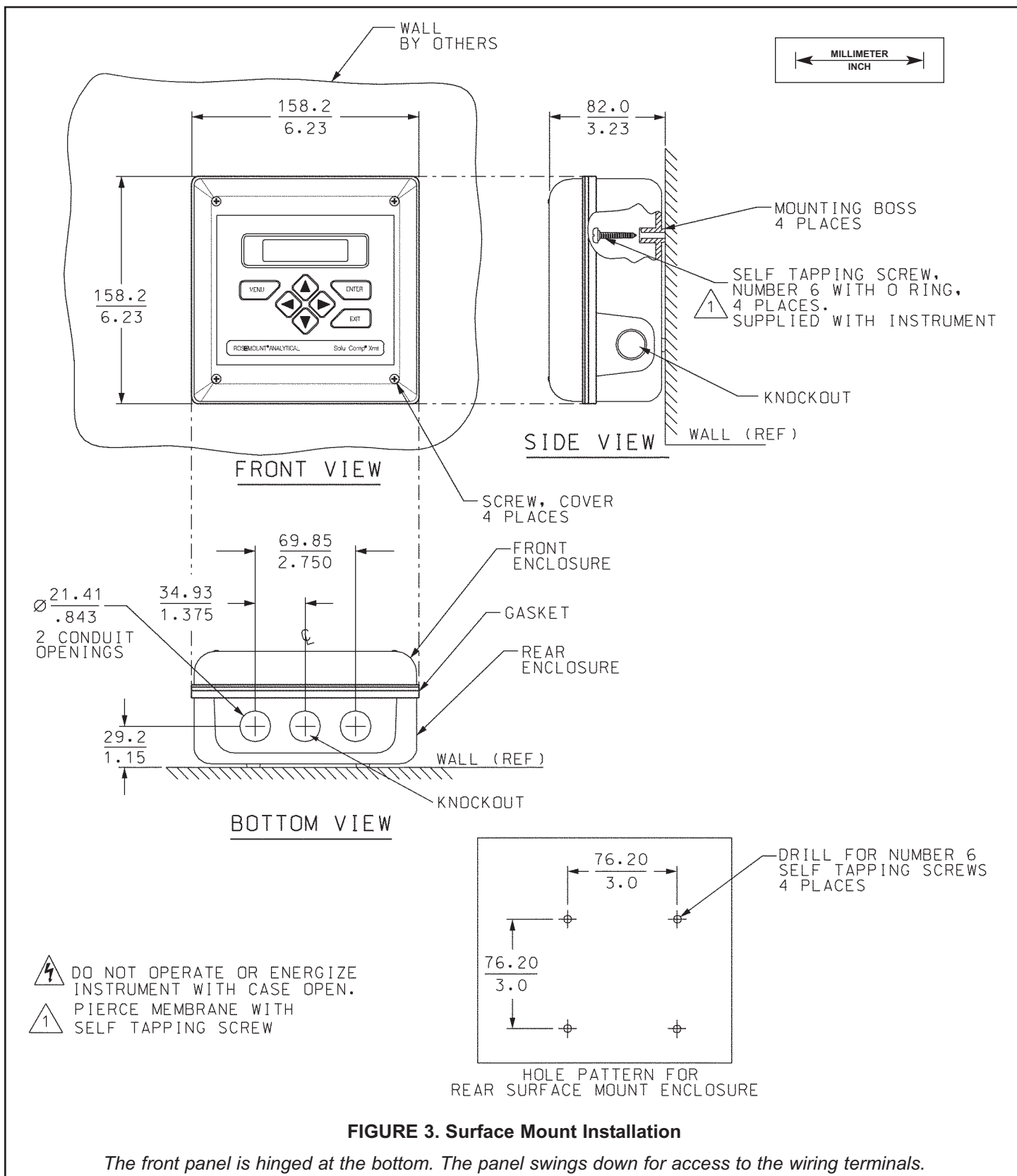

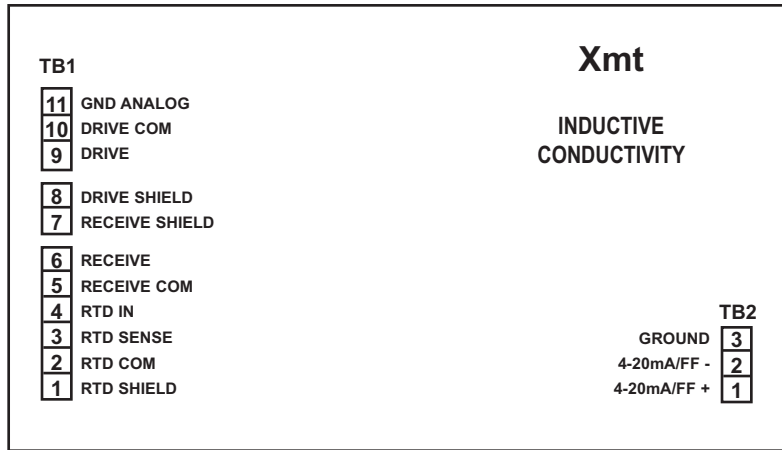

PANEL MOUNT

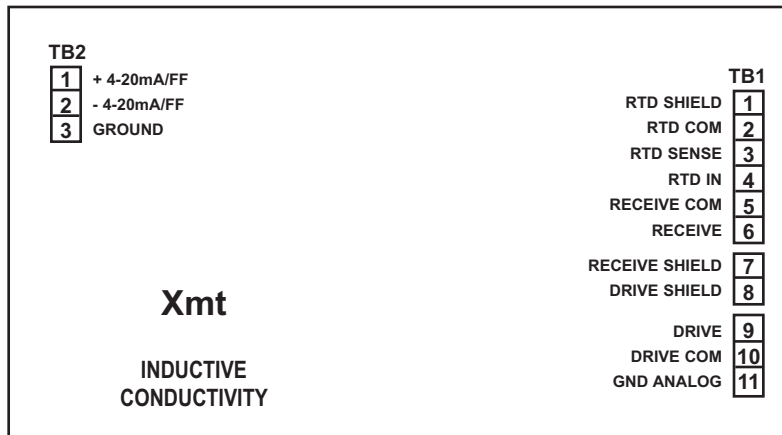

PIPE/SURFACE MOUNT

FIGURE 4. Loop Power and Sensor Wiring

MAIN MENU

MENU TREE FOR MODEL SOLU COMP Xmt-T-FF/FI TRANSMITTER

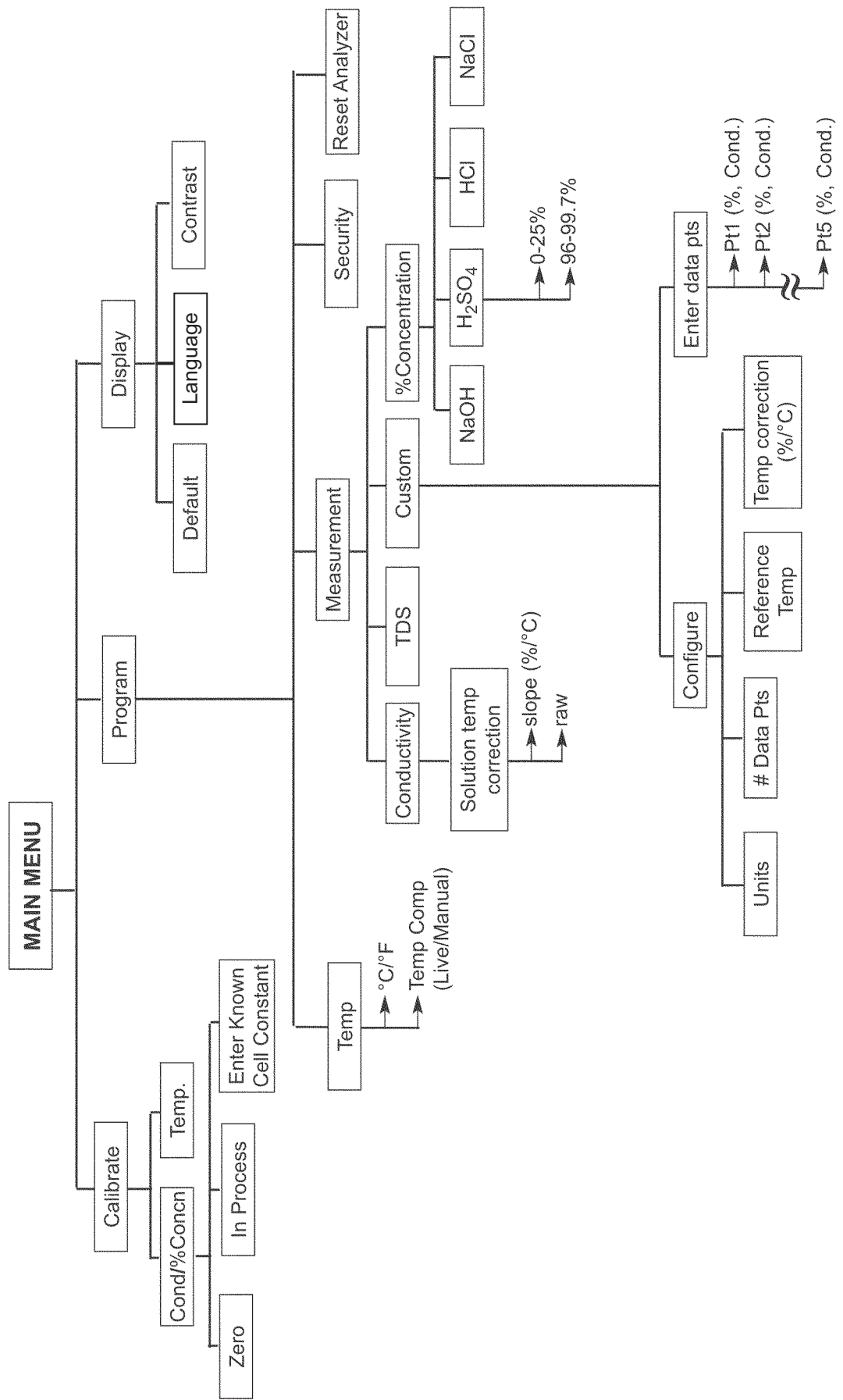

This page is left blank intentionally



*The right people,
the right answers,
right now.*

**ROSEMOUNT ANALYTICAL
CUSTOMER SUPPORT CENTER
1-800-854-8257**



Credit Cards for U.S. Purchases Only.



ON-LINE ORDERING NOW AVAILABLE ON OUR WEB SITE
<http://www.raihome.com>

Specifications subject to change without notice.

Emerson Process Management

2400 Barranca Parkway
Irvine, CA 92606 USA
Tel: (949) 757-8500
Fax: (949) 474-7250
<http://www.raihome.com>

© Rosemount Analytical Inc. 2010

