

FOUNDATION® Fieldbus Two-Wire Contacting Conductivity Transmitter



For additional information, please visit our website
at www.emersonprocess.com/raihome/liquid/.

ESSENTIAL INSTRUCTIONS

READ THIS PAGE BEFORE PROCEEDING!

Your purchase from Rosemount Analytical, Inc. has resulted in one of the finest instruments available for your particular application. These instruments have been designed, and tested to meet many national and international standards. Experience indicates that its performance is directly related to the quality of the installation and knowledge of the user in operating and maintaining the instrument. To ensure their continued operation to the design specifications, personnel should read this manual thoroughly before proceeding with installation, commissioning, operation, and maintenance of this instrument. If this equipment is used in a manner not specified by the manufacturer, the protection provided by it against hazards may be impaired.

- Failure to follow the proper instructions may cause any one of the following situations to occur: Loss of life; personal injury; property damage; damage to this instrument; and warranty invalidation.
- Ensure that you have received the correct model and options from your purchase order. Verify that this manual covers your model and options. If not, call 1-800-854-8257 or 949-757-8500 to request correct manual.
- For clarification of instructions, contact your Rosemount representative.
- Follow all warnings, cautions, and instructions marked on and supplied with the product.
- Use only qualified personnel to install, operate, update, program and maintain the product.
- Educate your personnel in the proper installation, operation, and maintenance of the product.
- Install equipment as specified in the Installation section of this manual. Follow appropriate local and national codes. Only connect the product to electrical and pressure sources specified in this manual.
- Use only factory documented components for repair. Tampering or unauthorized substitution of parts and procedures can affect the performance and cause unsafe operation of your process.
- All equipment doors must be closed and protective covers must be in place unless qualified personnel are performing maintenance.
- If this equipment is used in a manner not specified by the manufacturer, the protection provided by it against hazards may be impaired.

▲ WARNING

EXPLOSION HAZARD
DO NOT OPEN WHILE CIRCUIT IS LIVE
DO NOT RUB OR CLEAN WITH SOLVENTS
9241589-00/A

SPECIFICATIONS - GENERAL

Case: ABS (panel mount), polycarbonate (pipe/surface mount). Both versions are NEMA 4X/CSA 4 (IP65).

Dimensions

Panel (code -10): 6.10 x 6.10 x 3.72 in. (155 x 155 x 94.5 mm)

Surface/Pipe (code -11): 6.23 x 6.23 x 3.23 in. (158 x 158 x 82 mm)

Conduit openings: Accepts PG13.5 or 1/2 in. conduit fittings

Ambient Temperature: 32 to 122°F (0 to 50°C). Some degradation of display above 50°C.

Storage Temperature: -4 to 158°F (-20 to 70°C)

Relative Humidity: 10 to 90% (non-condensing)

Weight/Shipping Weight: 3 lb/4 lb (1.5 kg/2.0 kg)

Display: Two line, 16-character display. Character height: 4.8 mm; first line shows process variable, second line shows process temperature and output current. Fault and warning messages, when triggered, alternate with temperature and output readings.

During calibration and programming, messages, prompts, and editable values appear on the two-line display.

Temperature resolution: 0.1°C ($\leq 99.9^\circ\text{C}$); 1°C ($\geq 100^\circ\text{C}$)

RFI/EMI: EN-61326 

Power & Load Requirements: A power supply voltage of 9-32 Vdc at 13 mA is required.

Intrinsic Safety:



Class I, II, III, Div. 1
Groups A-G
T4 Tamb = 50°C



Class I, II, III, Div. 1
Groups A-G
T4 Tamb = 50°C

ATEX

 1180



II 1 G
Baseefa04ATEX0214X
EEx ia IIC T4
Tamb = 0°C to 50°C

Non-Incendive:



Class I, Div. 2, Groups A-D
Dust Ignition Proof
Class II & III, Div. 1, Groups E-G
NEMA 4/4X Enclosure



Class I, Div. 2, Groups A-D
Dust Ignition Proof
Class II & III, Div. 1, Groups E-G
NEMA 4/4X Enclosure
T4 Tamb = 50°C

FUNCTIONAL SPECIFICATIONS

Automatic Temperature Compensation:

- 3-wire Pt 100 or Pt 1000 RTD
- Conductivity: 0 to 200°C (32 to 392°F)
- Resistivity: 0 to 100°C (32 to 212°F)
- Low Conductivity: 0 to 100°C (32 to 212°F)

Diagnostics: The internal diagnostics can detect:

- Calibration Error
- Temperature Slope Error
- High Temperature Warning
- Low Temperature Warning
- ROM Failure
- Zero Error
- CPU Failure
- Input Warning

Once one of the above is diagnosed, the Xmt-C will display a message describing the problem.

Digital Communications:

HART: PV, SV, and TV assignable to measurement (conductivity, resistivity, or concentration), temperature, and raw conductivity. Raw conductivity is measured conductivity before temperature correction.

Fieldbus: Three AI blocks assignable to measurement (conductivity, resistivity, or concentration), temperature, and raw conductivity. Raw conductivity is measured conductivity before temperature correction. Execution time 75 msec. One PID block; execution time 150 msec. Device type: 4084. Device revision: 1. Certified to ITK 4.5.

TRANSMITTER SPECIFICATIONS @ 25°C

Measured Range: 0-20,000 µS/cm

Accuracy: ± 0.7% of reading and ± 0.002 µS/cm

Repeatability: ± 0.25% of reading

Temperature Accuracy:

- ± 0.2°C between 0 and 50°C
- ± 0.5°C above 50°C
- (excludes inaccuracies in sensor)

Temperature Compensation: Slope 0-5%/°C, ultra-pure water, cation conductivity, or raw (uncompensated) conductivity.

Compatible RTD: 100Ω or 1000Ω with automatic recognition

Ambient Temperature Coefficient:

± 0.05% of reading/°C

Maximum Cable Length: 200 ft (61 m)

LOOP SPECIFICATIONS

Accuracy: under controlled laboratory conditions at 25°C (77°F) with perfectly calibrated ENDURANCE sensor of appropriate cell constant:

Cell Constant	Range	Loop accuracy
0.01/cm	up to 50 µS/cm	±0.7% of reading ±0.002 µS/cm
0.1/cm	0.4 to 50 µS/cm 50 to 200 µS/cm	±0.7% of reading ±2% of reading
1.0/cm	4 to 5000 µS/cm 5000 to 20,000 µS/cm	±0.7% of reading ±2% of reading

Calibration: Calibrate against previously calibrated standard sensor and analyzer, or calibrate against solution of known conductivity.

SENSOR SELECTION GUIDELINES

Cell Constant	Suggested Conductivity Range
0.01/cm	up to 50 µS/cm
0.1/cm	0.4 to 500 µS/cm
1.0/cm	4 to 20,000 µS/cm

Note: The conductivity values shown in the above chart are for UNCOMPENSATED (or RAW) conductivity at 25°C. Maximum range values will vary due to temperature compensation selection, process temperature, and other process conditions.

RECOMMENDED SENSORS:

- Model 140 Retractable Conductivity
- Model 141 Insertion High Conductivity
- Model 142 Insertion Low Conductivity
- Model 150 Insertion/Submersion Conductivity
- Model 400 Screw-In Low Conductivity
- Model 400VP Screw-In Low Conductivity
- Model 401 Screw-In High Conductivity
- Model 402 Retractable Conductivity
- Model 402VP Retractable Conductivity
- Model 403 Sanitary Conductivity
- Model 403VP Sanitary Conductivity
- Model 404 Low Flow Conductivity

QUICK START GUIDE

FOR MODEL SOLU COMP Xmt-C-FF/FI TRANSMITTER

1. Refer to page 5 for installation instructions.
2. Wire conductivity sensor to the transmitter. Refer to the sensor instruction sheet for details.
3. Once connections are secure and verified, apply DC power to the transmitter.
4. When the transmitter is powered up for the first time, **Quick Start** screens appear. Using **Quick Start** is easy.
 - a. A blinking field shows the position of the cursor.
 - b. Use the ◀ or ▶ key to move the cursor left or right. Use the ▲ or ▼ key to move the cursor up or down or to increase or decrease the value of a digit. Use the ▲ or ▼ key to move the decimal point.
 - c. Press ENTER to store a setting. Press EXIT to leave without storing changes. Pressing EXIT also returns the display to the previous screen.

```
English      Français
Español     >>
```

5. Choose the desired language. Select >> to show more choices.

```
Measure?      Cond
Resistivity   >>
```

6. Choose measurement: **Conductivity, Resistivity, Total Dissolved Solids, or Custom.**

```
Measure?
TDS          Custom >>
```

```
Cell Constant?
1.0000/cm
```

7. Enter the cell constant. See label attached to sensor.

```
ROSEMOUNT ANALYTICAL
ENDURANCE™ CONDUCTIVITY SENSOR
MODEL/PN: 404-11-16-50-54   REV B   C99   PT1000
MAX TEMP: 140°F AT 20 psig  CAL CONST= 450  K= .01
MAX PRESS: 100 psig AT 77°F  CELL CONST= .00950/cm
```

If there is no cell constant on the label, calculate it from the equation:

$$\text{cell const} = K \left(\frac{500 + \text{cal const}}{1000} \right)$$

```
Temperature in?
°C              °F
```

8. Choose temperature units: °C or °F.

```
Enter Data Pts
Ref Temp      Slope
```

9. If you selected **Custom**, you must enter the appropriate conductivity and concentration data points. From the main display, press MENU. Choose **Program** followed by **Measurement** and **Custom**. The screen shown at left appears. Select **Enter Data Pts**. Follow the prompts and enter the display units, the number of data points, and enter the concentration and conductivity data points. Enter the reference temperature and the temperature coefficient (slope). Once the analyzer has been configured, press EXIT. For a guide to the program menu, see the menu tree on page 10.

```
Concentration
Units?      %   PPM   none
```

10. To change output settings, to scale the 4-20 mA output, to change measurement-related settings from the default values, and to set security codes, press MENU. Select Program and follow the prompts. Refer to the menu tree on page 10.

11. To return the transmitter to default settings, choose **ResetAnalyzer** in the Program menu.

UNPACKING AND INSPECTION

Inspect the shipping container. If it is damaged, contact the shipper immediately for instructions. Save the box. If there is no apparent damage, unpack the container. Be sure all items shown on the packing list are present. If items are missing, notify Emerson Process Management immediately.

INSTALLATION

1. Although the transmitter is suitable for outdoor use, do not install it in direct sunlight or in areas of extreme temperatures.
2. Install the transmitter in an area where vibrations and electromagnetic and radio frequency interference are minimized or absent.
3. Keep the transmitter and sensor wiring at least one foot from high voltage conductors. Be sure there is easy access to the transmitter.
4. The transmitter is suitable for panel (Figure 1), pipe (Figure 2), or surface (Figure 3) mounting.
5. The transmitter case has two 1/2-inch (PG13.5) conduit openings and either one or four 1/2-inch knockouts. The pipe/surface mount transmitter has one knockout. The panel mount Xmt-C-FF/FI has four knockouts. One conduit opening is for the power/output cable; the other opening is for the sensor cable. The knockout should be removed only if a second sensor is required, i.e., if free chlorine with continuous pH correction is being measured.
6. Use weathertight cable glands to keep moisture out to the transmitter. If conduit is used, plug and seal the connections at the transmitter housing to prevent moisture from getting inside the instrument.
7. To reduce the likelihood of stress on wiring connections, do not remove the hinged front panel (-11 models) from the base during wiring installation. Allow sufficient wire leads to avoid stress on conductors.

NOTE: Use Stiffner 32939-00 provided in Kit 24062-00 to electrically bond enclosure to Earth Ground.

The figure to the right shows how to remove the knockouts. The knockout grooves are on the outside of the case. Place the screwdriver blade on the inside of the case and align it approximately along the groove. Rap the screwdriver sharply with a hammer until the groove cracks. Move the screwdriver to an uncracked portion of the groove and continue the process until the knockout falls out. Use a small knife blade to remove the flash from the inside of the hole.

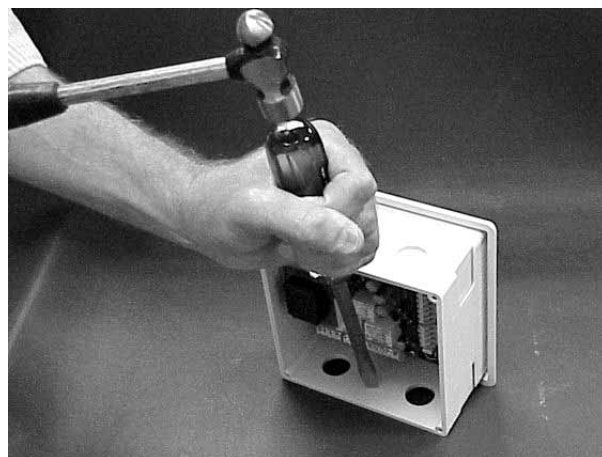

Removing the Knockouts

Panel Mounting.

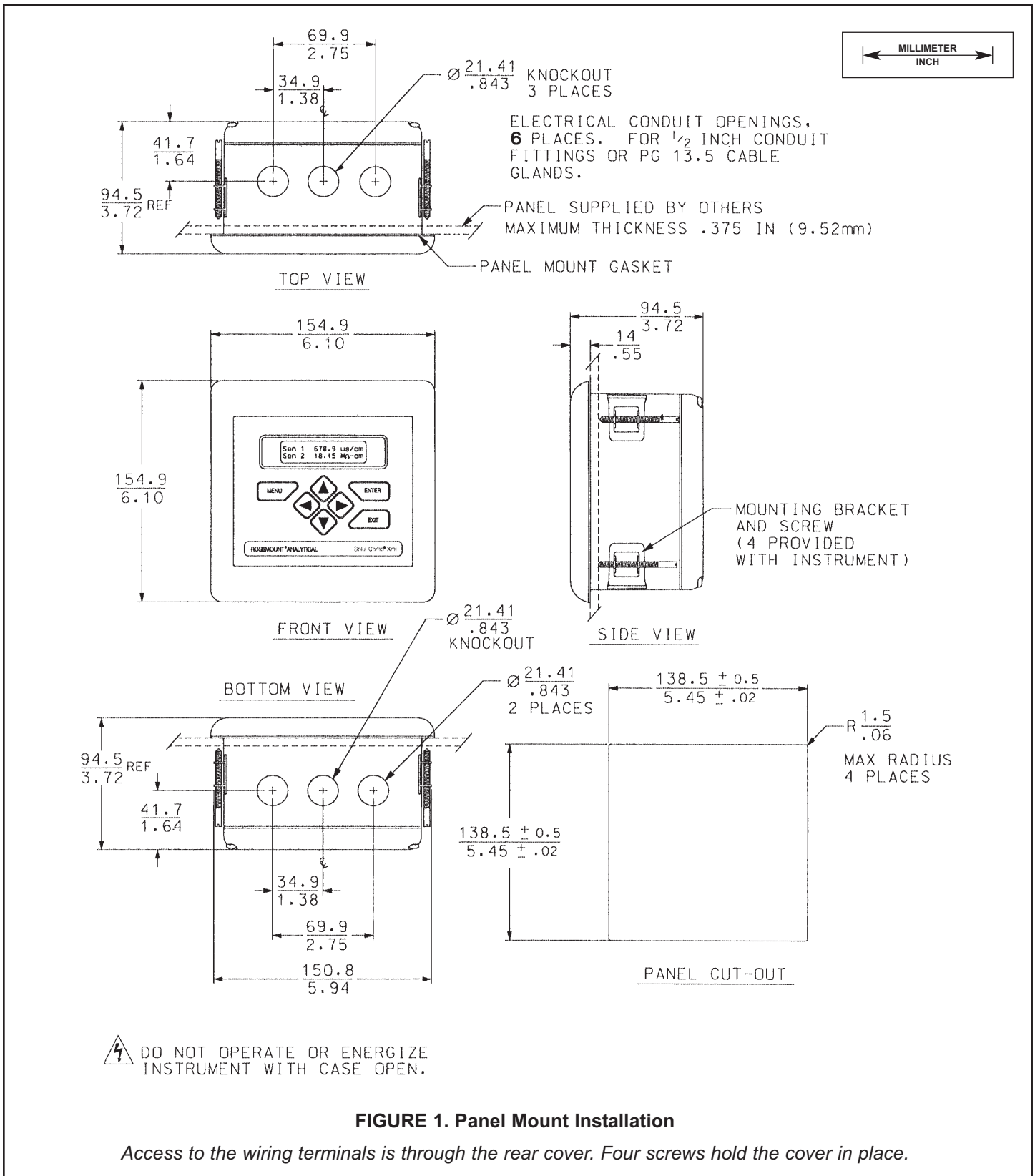

Pipe Mounting.

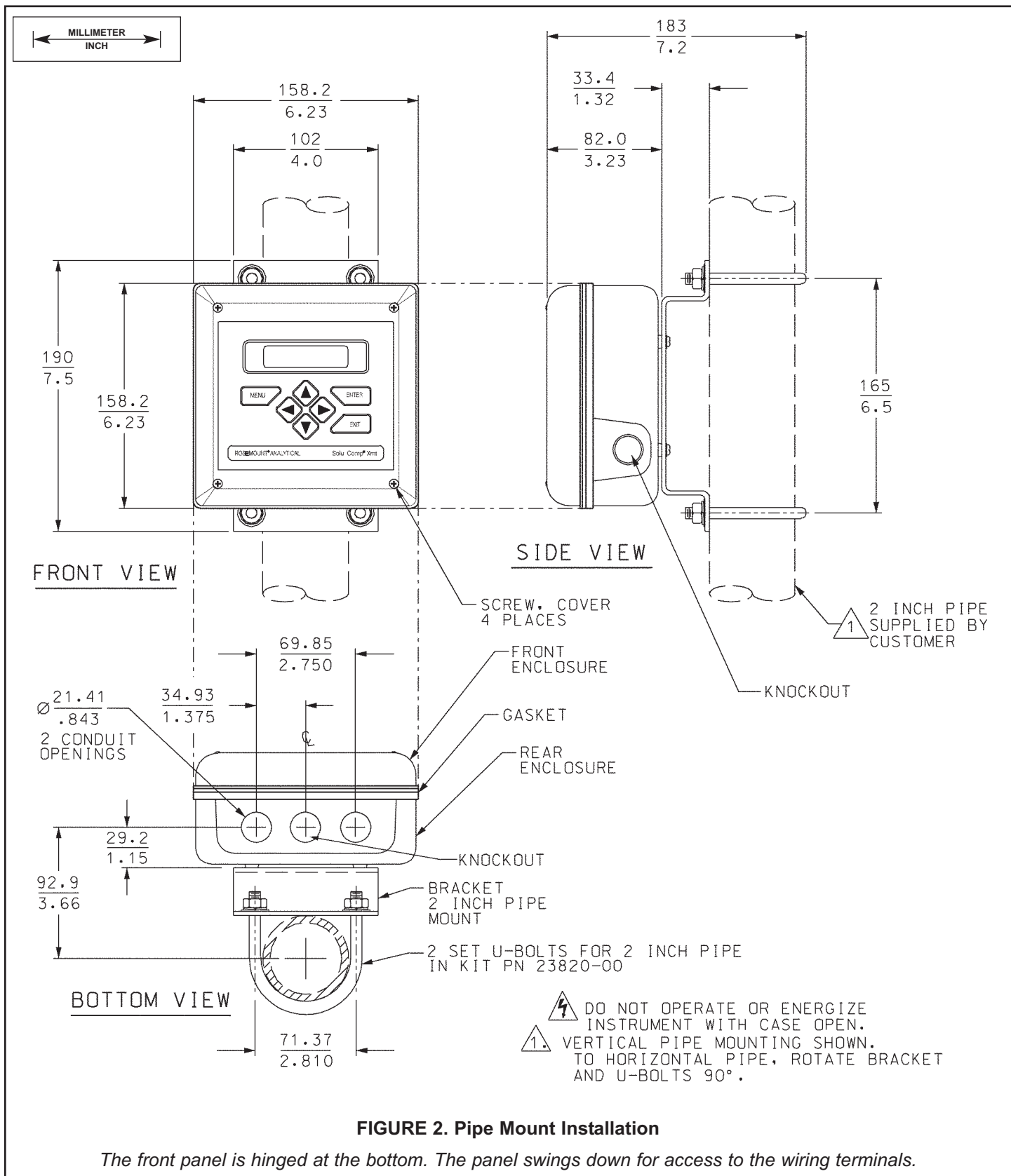

Surface Mounting.

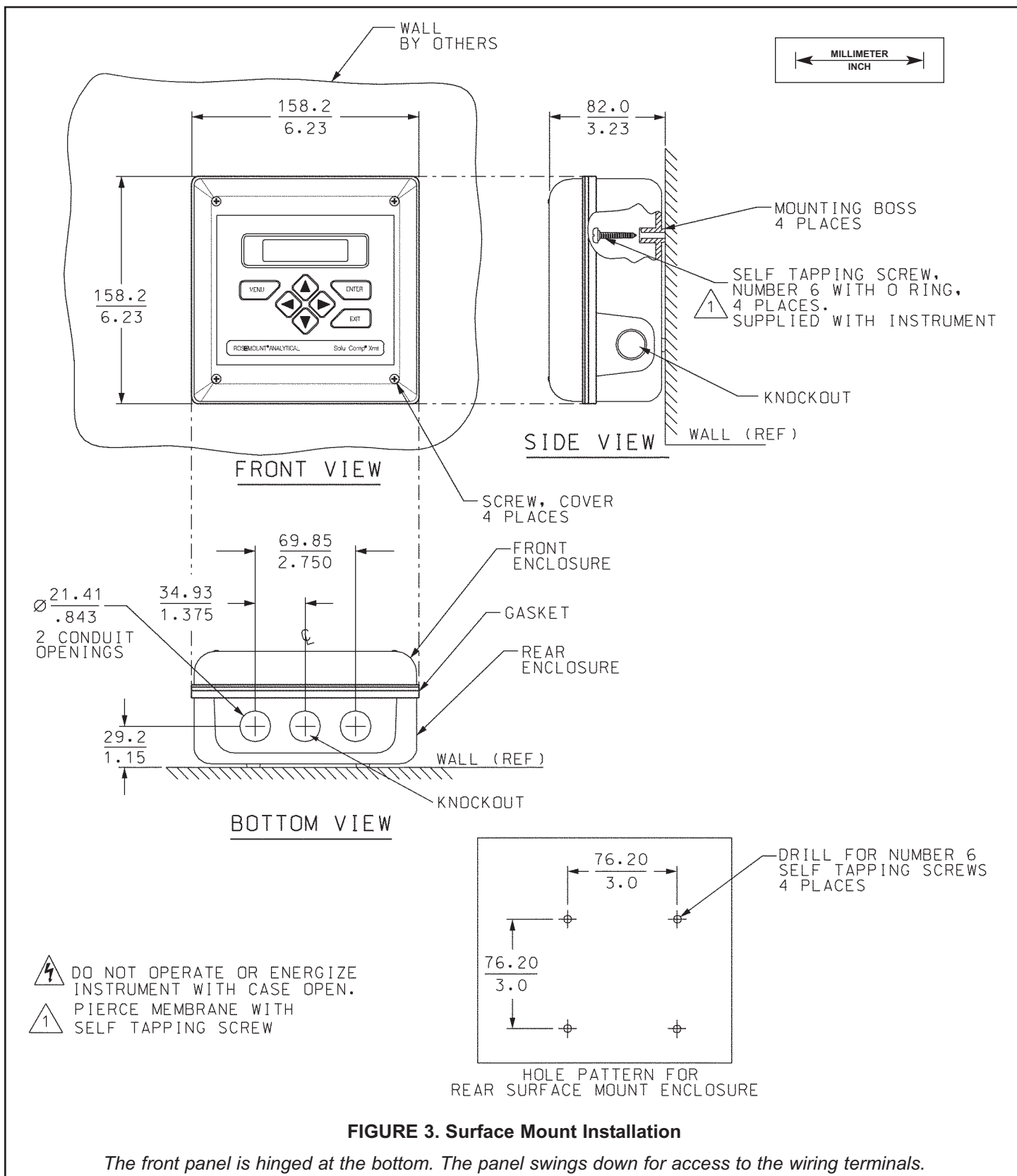

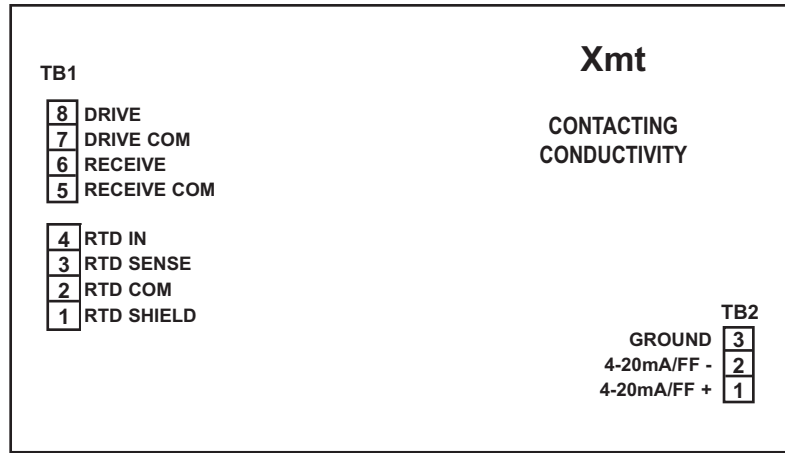

PANEL MOUNT

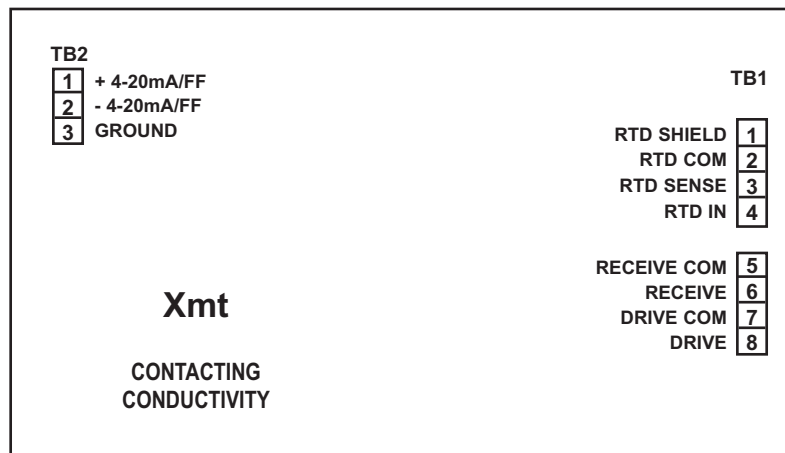

PIPE/SURFACE MOUNT

FIGURE 5. Loop Power and Sensor Wiring

MAIN MENU

MENU TREE FOR MODEL SOLU COMP Xmt-C-FF/FI TRANSMITTER

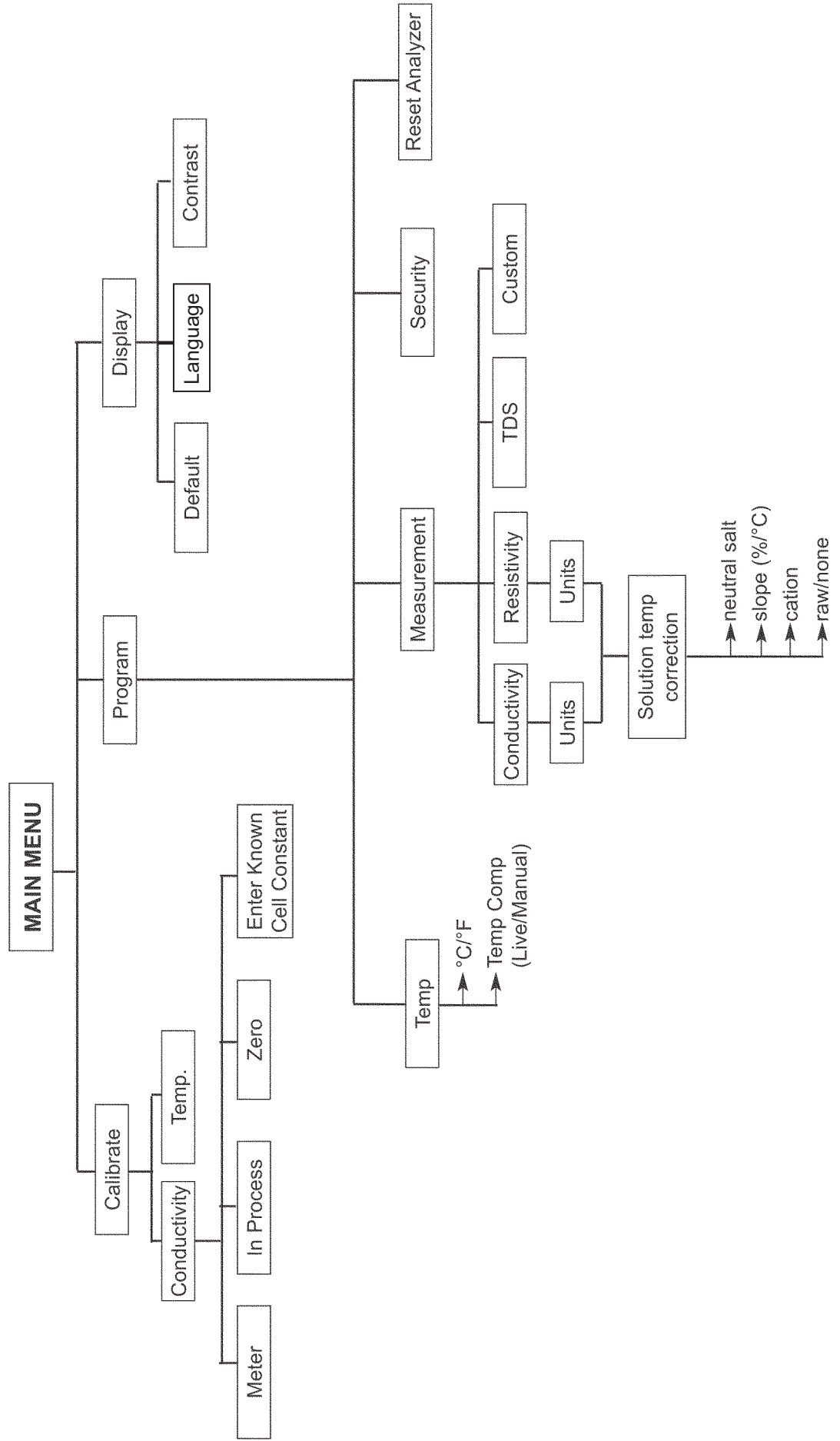

EC Declaration of Conformity

Xmt-C-HT/FI/FI

We, Emerson Process Management
Heath Place - Bognor Regis
West Sussex PO22 9SH
England

Declare under out sole responsibility that the product,

Model Xmt-C-HT Contacting Conductivity Transmitter, HART;
Model Xmt-C-FF Contacting Conductivity Transmitter, Foundation Fieldbus;
Model Xmt-C-FI Contacting Conductivity Transmitter, FISCO Fieldbus ;

manufactured by,

Emerson Process Management
Rosemount Analytical
2400 Barranca Parkway
Irvine, California 92606
USA

to which this declaration relates, is in conformity with the provisions of the European community Directives, including the latest amendments, as shown in the attached schedule.

Assumption of conformity is based on the application of the harmonized standards and, when applicable or required, a European Community notified body certification, as shown in the attached schedule.



(signature)

Andy Kemish

(name printed)

Vice President Analytical Europe

(function name printed)

March 24, 2009

(date of issue)

**Schedule
EC Declaration of Conformity**

EMC Directive (2004/108/EC)

Model Xmt-C-HT Contacting Conductivity Transmitter, HART;
Model Xmt-C-FF Contacting Conductivity Transmitter, Foundation Fieldbus;
Model Xmt-C-FI Contacting Conductivity Transmitter, FISCO Fieldbus ;

EN 61326-1: 2006

ATEX Directive (94/9/EC)

Provisions of the directive fulfilled by the equipment:
Equipment Group II, Category 1 G (EEx ia IIC T4)

Model Xmt-C-HT Contacting Conductivity Transmitter, HART;
Model Xmt-C-FF Contacting Conductivity Transmitter, Foundation Fieldbus;
Model Xmt-C-FI Contacting Conductivity Transmitter, FISCO Fieldbus ;

**Basecfa04ATEX0214X -- Intrinsically Safe Certificate
60079-C:2006 60079-11:2007 EN50284:1999**

ATEX Notified Bodies for EC Type Examination Certificate

Basecfa [Notified Body Number: 1180]
Rockhead Business Park, Studen Lane
Buxton, Derbyshire SK17 9RZ
United Kingdom

ATEX Notified Body for Quality Assurance

Basecfa [Notified Body Number: 1180]
Rockhead Business Park, Studen Lane
Buxton, Derbyshire SK17 9RZ
United Kingdom



*The right people,
the right answers,
right now.*

ROSEMOUNT ANALYTICAL
CUSTOMER SUPPORT CENTER
1-800-854-8257



Credit Cards for U.S. Purchases Only.



ON-LINE ORDERING NOW AVAILABLE ON OUR WEB SITE
<http://www.raihome.com>

Specifications subject to change without notice.

Emerson Process Management

2400 Barranca Parkway
Irvine, CA 92606 USA
Tel: (949) 757-8500
Fax: (949) 474-7250
<http://www.raihome.com>

© Rosemount Analytical Inc. 2010

