

HART SMART[®] Two-Wire pH/ORP Transmitter

For additional information, visit our website
at www.emersonprocess.com/rainhome/liquid/.

ESSENTIAL INSTRUCTIONS

READ THIS PAGE BEFORE PROCEEDING!

Your purchase from Rosemount Analytical, Inc. has resulted in one of the finest instruments available for your particular application. These instruments have been designed, and tested to meet many national and international standards. Experience indicates that its performance is directly related to the quality of the installation and knowledge of the user in operating and maintaining the instrument. To ensure their continued operation to the design specifications, personnel should read this manual thoroughly before proceeding with installation, commissioning, operation, and maintenance of this instrument. If this equipment is used in a manner not specified by the manufacturer, the protection provided by it against hazards may be impaired.

- Failure to follow the proper instructions may cause any one of the following situations to occur: Loss of life; personal injury; property damage; damage to this instrument; and warranty invalidation.
- Ensure that you have received the correct model and options from your purchase order. Verify that this manual covers your model and options. If not, call 1-800-854-8257 or 949-757-8500 to request correct manual.
- For clarification of instructions, contact your Rosemount representative.
- Follow all warnings, cautions, and instructions marked on and supplied with the product.
- Use only qualified personnel to install, operate, update, program and maintain the product.
- Educate your personnel in the proper installation, operation, and maintenance of the product.
- Install equipment as specified in the Installation section of this manual. Follow appropriate local and national codes. Only connect the product to electrical and pressure sources specified in this manual.
- Use only factory documented components for repair. Tampering or unauthorized substitution of parts and procedures can affect the performance and cause unsafe operation of your process.
- All equipment doors must be closed and protective covers must be in place unless qualified personnel are performing maintenance.
- If this equipment is used in a manner not specified by the manufacturer, the protection provided by it against hazards may be impaired.



WARNING

EXPLOSION HAZARD.

DO NOT OPEN WHILE CIRCUIT IS LIVE.

DO NOT RUB OR CLEAN WITH SOLVENTS.

9241589-00/A

CAUTION

If a Model 375 Universal Hart[®] Communicator is used with these transmitters, the software within the Model 375 may require modification.

If a software modification is required, please contact your local Emerson Process Management Service Group or National Response Center at 1-800-654-7768.

SPECIFICATIONS - GENERAL

Case: ABS. Pipe, surface, and panel mount versions are NEMA 4X/CSA 4 (IP65)

Dimensions

Panel (code -10): 6.10 x 6.10 x 3.72 in.
(155 x 155 x 94.5 mm)

Surface/Pipe (code -11): 6.23 x 6.23 x 3.23 in.
(158 x 158 x 82 mm); see page 15 for dimensions of pipe mounting bracket.

Conduit openings: Accepts PG13.5 or 1/2 in. conduit fittings

Ambient Temperature: 32 to 122°F (0 to 50°C).
Some degradation of display above 50°C.

Storage Temperature: -4 to 158°F (-20 to 70°C)

Relative Humidity: 10 to 90% (non-condensing)

Weight/Shipping Weight: 2 lb/3 lb (1 kg/1.5 kg)

Display: Two line, 16-character display. Character height: 4.8 mm; first line shows process variable (pH, ORP, conductivity, % concentration, oxygen, ozone, chlorine, or monochloramine), second line shows process temperature and output current. For pH/chlorine combination, pH may also be displayed. Fault and warning messages, when triggered, alternate with temperature and output readings.

During calibration and programming, messages, prompts, and editable values appear on the two-line display.

Temperature resolution: 0.1°C ($\leq 99.9^\circ\text{C}$);
1°C ($\geq 100^\circ\text{C}$)

Hazardous Location Approval: For details, see specifications for the measurement of interest.

RFI/EMI: EN-61326 

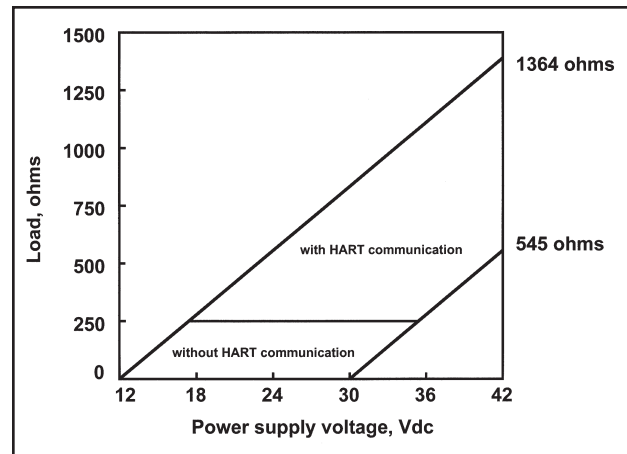

DIGITAL COMMUNICATIONS:

HART —

Power & Load Requirements: Supply voltage at the transmitter terminals should be at least 12 Vdc. Power supply voltage should cover the voltage drop on the cable plus the external load resistor required for HART communications (250 Ω minimum). Minimum power supply voltage is 12 Vdc. Maximum power supply voltage is 42.4 Vdc. The graph shows the supply voltage required to maintain 12 Vdc (upper line) and 30 Vdc (lower line) at the transmitter terminals when the current is 22 mA.

Analog Output: Two-wire, 4-20 mA output with superimposed HART^{®3} digital signal. Fully scalable over the operating range of the sensor.

Output accuracy: ± 0.05 mA

FUNCTIONAL SPECIFICATIONS

pH Range: 0 to 14

ORP Range: -1400 to +1400mV

Calibrations/standardization: The automatic buffer recognition uses stored buffer values and their temperature curves for the most common buffer standards available worldwide. The transmitter also performs a stabilization check on the sensor in each buffer.

A manual two-point calibration is made by immersing the sensor in two different buffer solutions and entering the pH values. The microprocessor automatically calculates the slope which is used for self-diagnostics. An error message will be displayed if the pH sensor is faulty. This slope can be read on the display and/or manually adjusted if desired.

An on-line one-point process standardization is accomplished by entering the pH or ORP value of a grab sample.

Preamplifier Location: A preamplifier must be used to convert the high impedance pH electrode signal to a low impedance signal for transmitter use. The integral preamplifier of the Model Xmt-P may be used when the sensor to transmitter distance is less than 15 ft (4.5 m). Locate the preamplifier in the sensor or junction box for longer distances.

Automatic Temperature Compensation: External 3-wire Pt100 RTD or Pt1000 RTD located in the sensor, compensates the pH reading for temperature fluctuations. Compensation covers the range -15 to 130°C (5 to 270°F). Manual temperature compensation is also selectable.

Accuracy: ±1 mV @ 25°C ±0.01 pH

Repeatability: ±1 mV @ 25°C ±0.01 pH

Diagnostics: The internal diagnostics can detect:

Calibration Error	Sensor Failure
High Temperature Warning	CPU Failure
Low Temperature Warning	Input Warning
ROM Failure	Glass Warning
Glass Failure	Reference Warning
Reference Failure	

Once one of the above is diagnosed, the display will show a message describing the problem.

DIGITAL COMMUNICATIONS:

HART (pH): PV assigned to pH. SV, TV, and 4V assignable to pH, temperature, mV, glass impedance, reference impedance, or RTD resistance.

HART (ORP): PV assigned to ORP. SV, TV, and 4V assignable to ORP, temperature, reference impedance, or RTD resistance.

Fieldbus (pH): Four AI blocks assigned to pH, temperature, reference impedance, and glass impedance.

Fieldbus (ORP): Three AI blocks assigned to ORP, temperature, and reference impedance.

Fieldbus (pH and ORP): Execution time 75 msec. One PID block; execution time 150 msec. Device type 4088. Device revision 1. Certified to ITK 4.6.

HAZARDOUS LOCATION APPROVALS

Intrinsic Safety (with appropriate safety barrier):



Class I, II, III, Div. 1
Groups A-G
T4 Tamb = 50°C



Class I, II, III, Div. 1
Groups A-G
T4 Tamb = 50°C

ATEX



CE 1180 II 1 G
Baseefa04ATEX0213X
EEx ia IIC T4
Tamb = 0°C to 50°C

Non-Incendive:



Class I, Div. 2, Groups A-D
Dust Ignition Proof
Class II & III, Div. 1, Groups E-G
NEMA 4/4X Enclosure



Class I, Div. 2, Groups A-D
Dust Ignition Proof
Class II & III, Div. 1, Groups E-G
NEMA 4/4X Enclosure
T4 Tamb = 50°C

QUICK START GUIDE

FOR MODEL SOLU COMP Xmt-P-HT TRANSMITTER

1. Refer to page 5 for installation instructions.
2. Wire pH or ORP sensor to the transmitter. See Figure 6 for panel mount; Figure 7 for pipe or surface mount. Refer to the sensor instruction sheet for details.
3. Once connections are secure and verified, apply power to the transmitter.
4. When the transmitter is powered up for the first time, **Quick Start** screens appear. Using **Quick Start** is easy.
 - a. A blinking field shows the position of the cursor.
 - b. Use the \leftarrow or \rightarrow key to move the cursor left or right. Use the \uparrow or \downarrow key to move the cursor up or down or to increase or decrease the value of a digit. Use the \uparrow or \downarrow key to move the decimal point.
 - c. Press ENTER to store a setting. Press EXIT to leave without storing changes. Pressing EXIT also returns the display to the previous screen.

English	Français
Español	>>

5. Choose the desired language. Choose >> to show more choices.

Measure?	pH
Redox	ORP

6. Choose measurement: **pH**, **ORP**, or **Redox**.

Use Preamp in?	
Xmtr	Sensor/JBox

7. Choose preamplifier location. Select **Xmtr** to use the integral preamplifier in the transmitter; select **Sensor/JBox** if your sensor has an integral preamplifier or if you are using a remote preamplifier located in a junction box.

Temperature in?	
°C	°F

8. Choose temperature units: °C or °F.

9. To change output settings, to scale the 4-20 mA output, to change measurement-related settings from the default values, and to set security codes, press MENU. Select Program and follow the prompts. Refer to the appropriate menu tree (page 11).

10. To return the transmitter to default settings, choose **ResetAnalyzer** in the Program menu.

UNPACKING AND INSPECTION

Inspect the shipping container. If it is damaged, contact the shipper immediately for instructions. Save the box. If there is no apparent damage, unpack the container. Be sure all items shown on the packing list are present. If items are missing, notify Emerson Process Management immediately.

INSTALLATION

1. Although the transmitter is suitable for outdoor use, do not install it in direct sunlight or in areas of extreme temperatures.
2. Install the transmitter in an area where vibrations and electromagnetic and radio frequency interference are minimized or absent.
3. Keep the transmitter and sensor wiring at least one foot from high voltage conductors. Be sure there is easy access to the transmitter.
4. The transmitter is suitable for panel (Figure 3), pipe (Figure 4), or surface (Figure 5) mounting.
5. The transmitter case has two 1/2-inch (PG13.5) conduit openings and either one or four 1/2-inch knockouts. The panel mount Xmt-P-HT has four knockouts. The pipe/surface mount transmitter has two knockouts*. One conduit opening is for the power/output cable; the other opening is for the sensor cable.

Figure 1 shows how to remove a knockout. The knockout grooves are on the outside of the case. Place the screwdriver blade on the inside of the case and align it approximately along the groove. Rap the screwdriver sharply with a hammer until the groove cracks. Move the screwdriver to an uncracked portion of the groove and continue the process until the knockout falls out. Use a small knife to remove the flash from the inside of the hole.

6. Use weathertight cable glands to keep moisture out to the transmitter. If conduit is used, plug and seal the connections at the transmitter housing to prevent moisture from getting inside the instrument.
7. To reduce the likelihood of stress on wiring connections, do not remove the hinged front panel (-11 models) from the base during wiring installation. Allow sufficient wire leads to avoid stress on conductors.

*NEMA plug may be supplied instead of knockout for pipe/surface version.

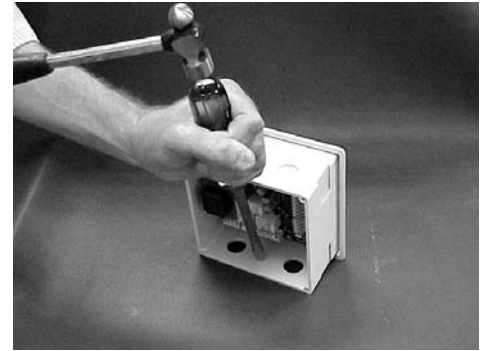

FIGURE 1. Removing the Knockouts

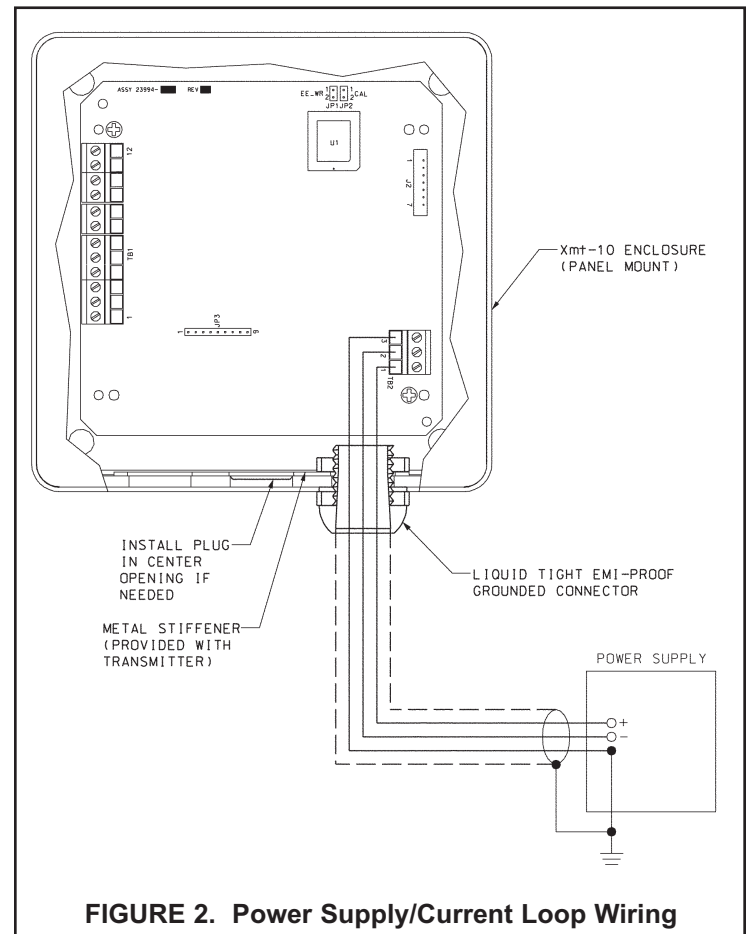
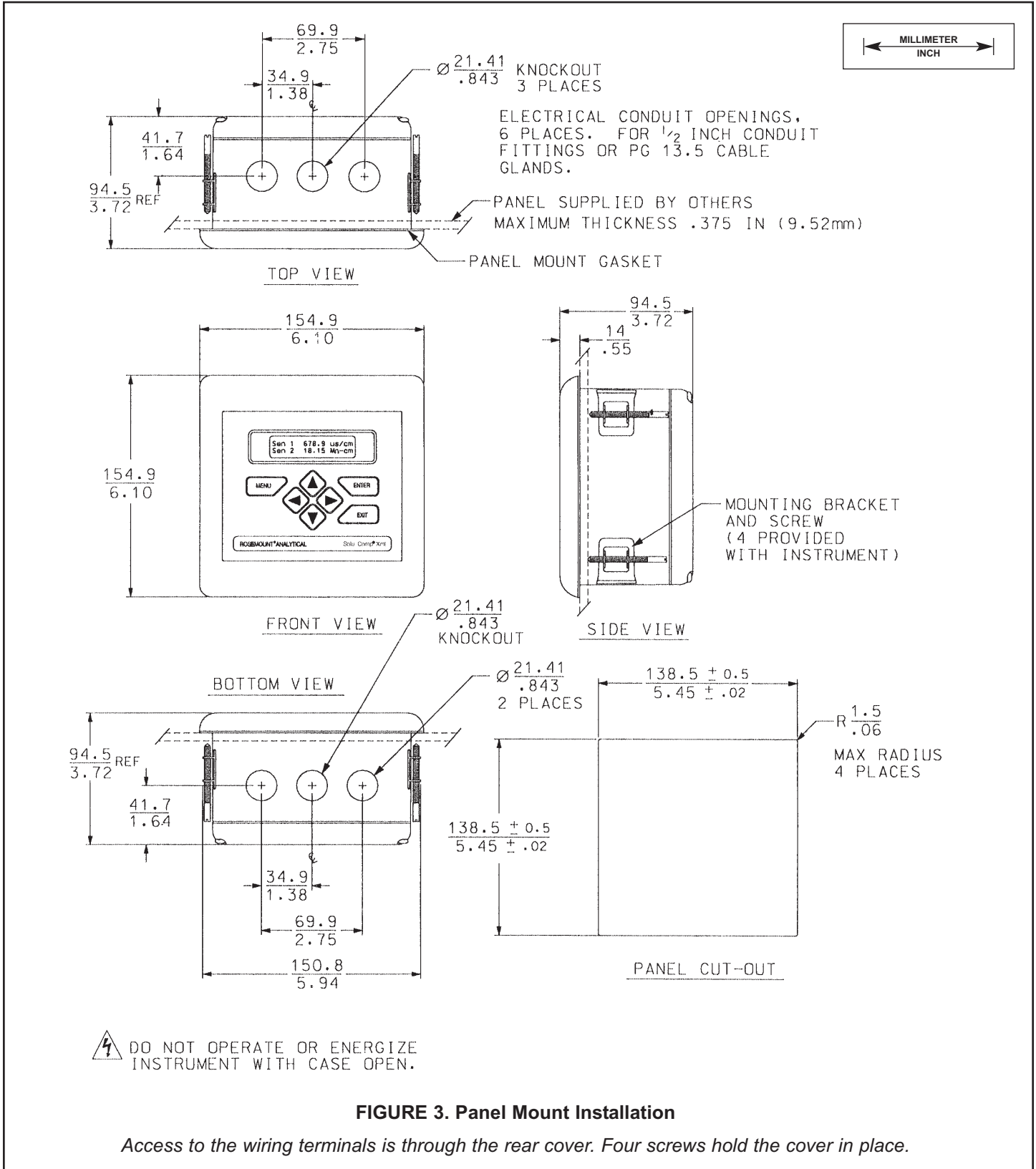
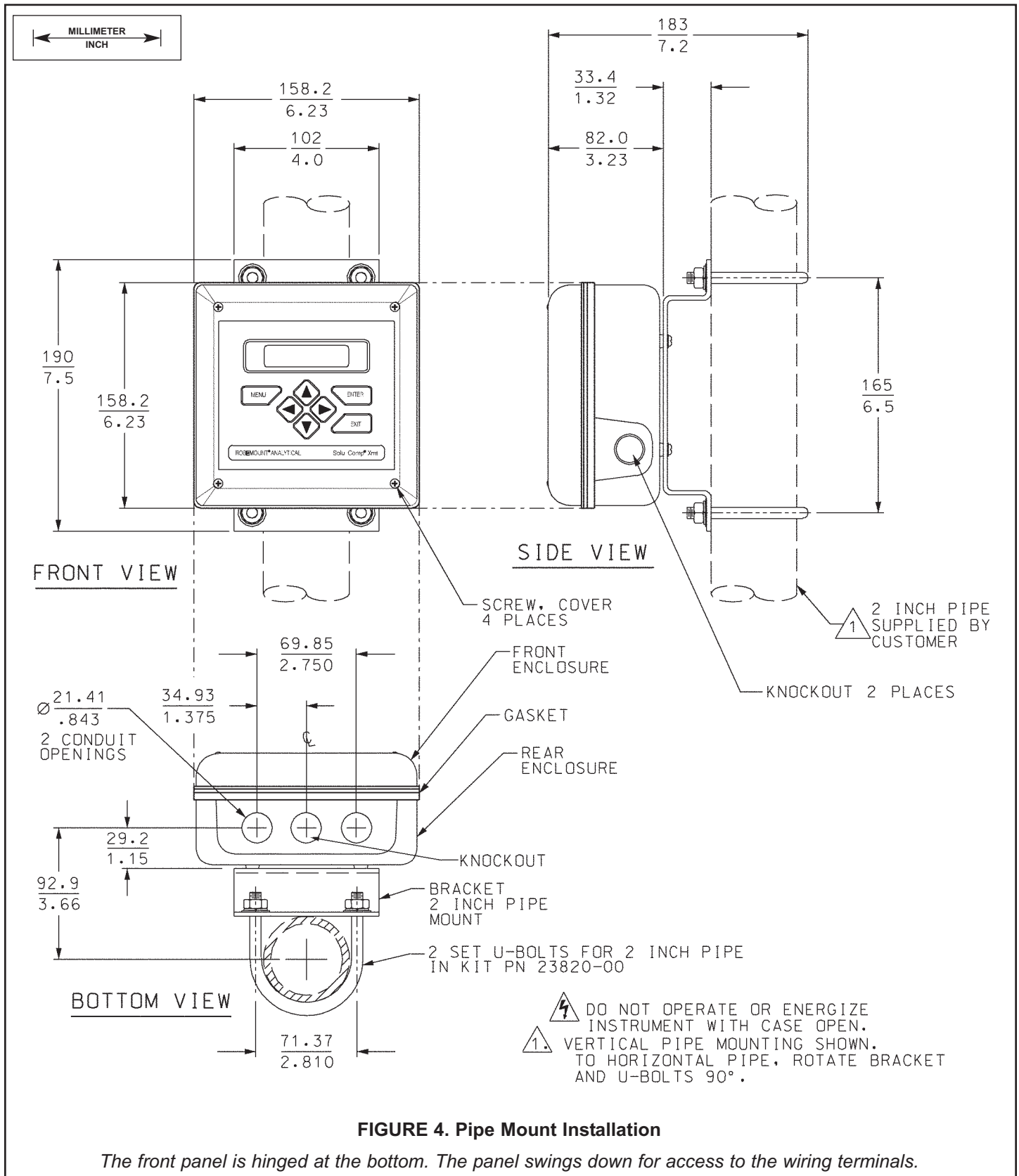

FIGURE 2. Power Supply/Current Loop Wiring

Panel Mounting.



Pipe Mounting.



Surface Mounting.

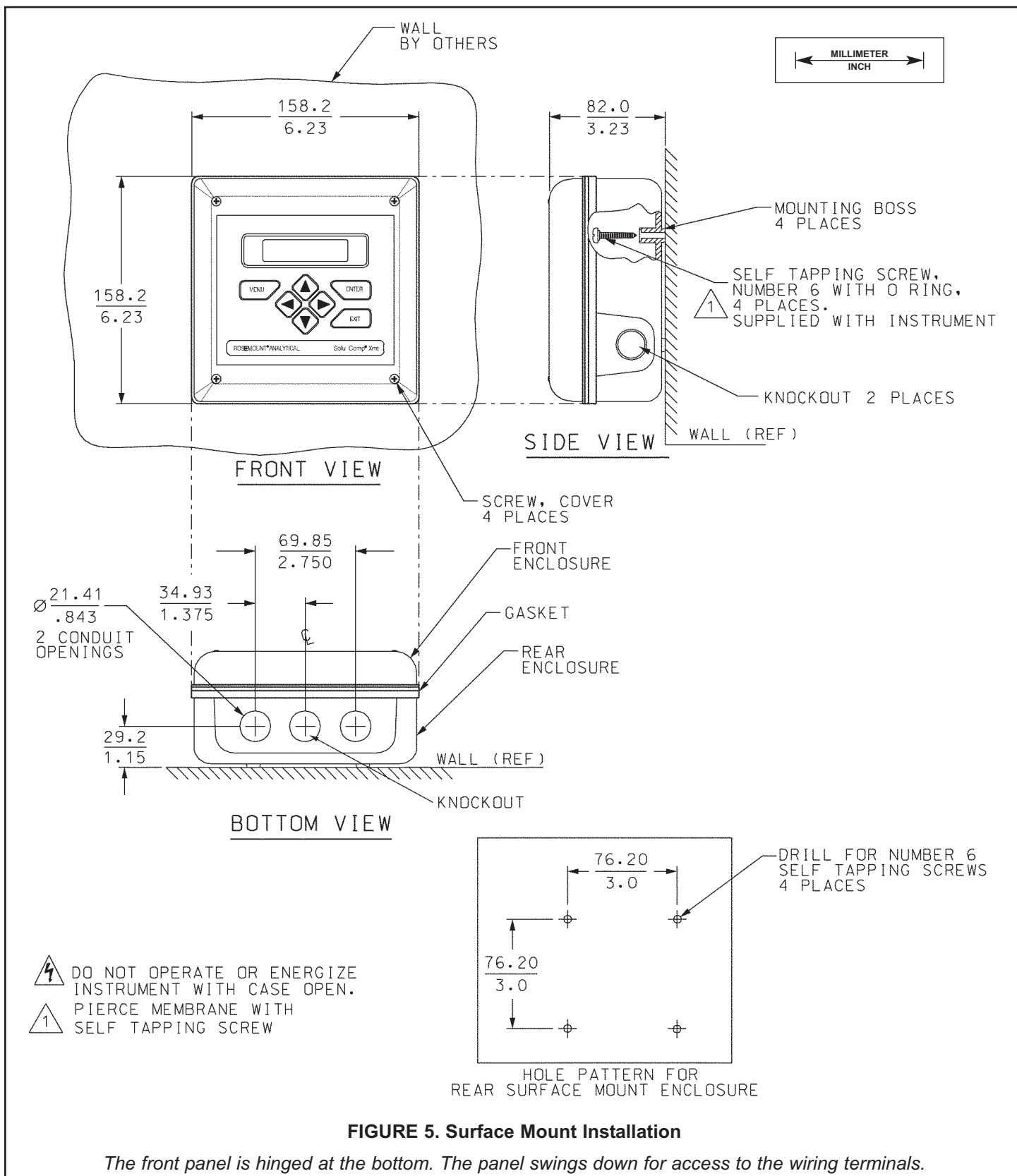

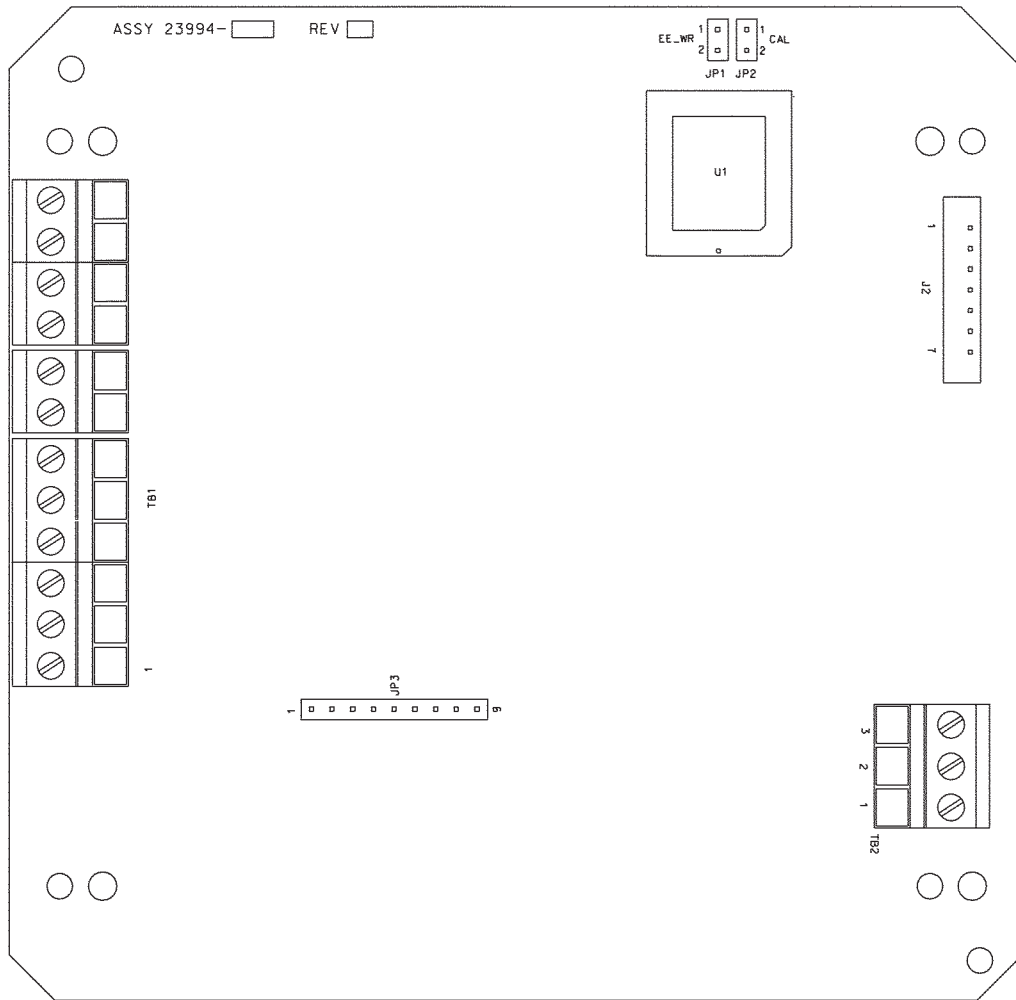

TB1		<p>pH/ORP CHLORINE/OXYGEN/OZONE</p>
12	CATHODE (NOT USED FOR pH/ORP)	
11	ANODE (NOT USED FOR pH/ORP)	
10	+ 5V	
9	- 5V	
8	pH/ORP IN	
7	pH/ORP GUARD	
6	SOLUTION GROUND	
5	REFERENCE IN	
4	REFERENCE GUARD	
3	RTD IN	
2	RTD SENSE	
1	RTD RETURN	

		TB2
		GROUND
3		
2	4-20mA/FF -	
1	4-20mA/FF +	

9241587-00/A

FIGURE 6. Loop Power and Sensor Wiring - Panel Mount

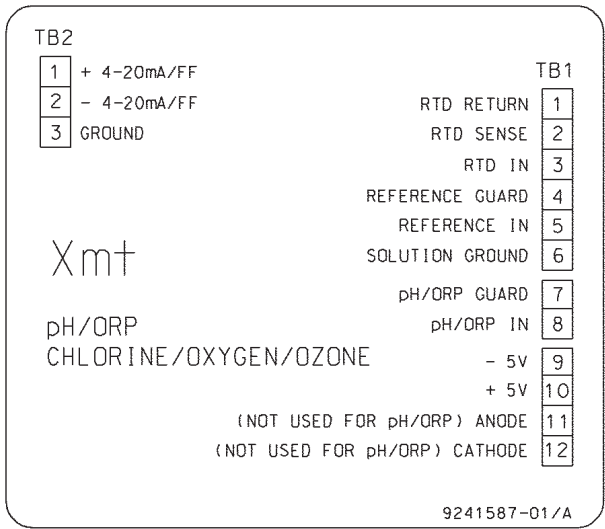
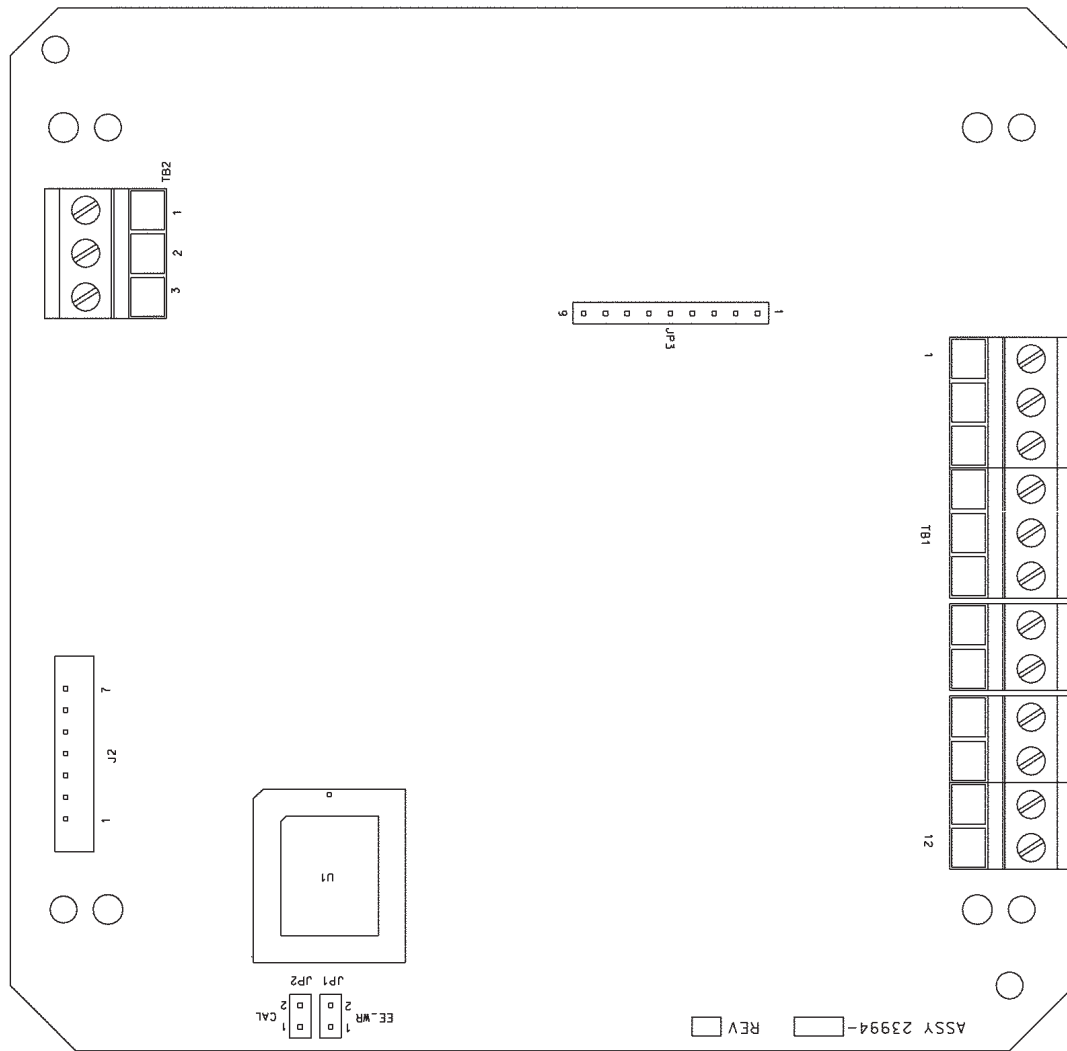

FIGURE 7. Loop Power and Sensor Wiring - Pipe/Surface Mount

HAZARDOUS AREA INSTALLATION

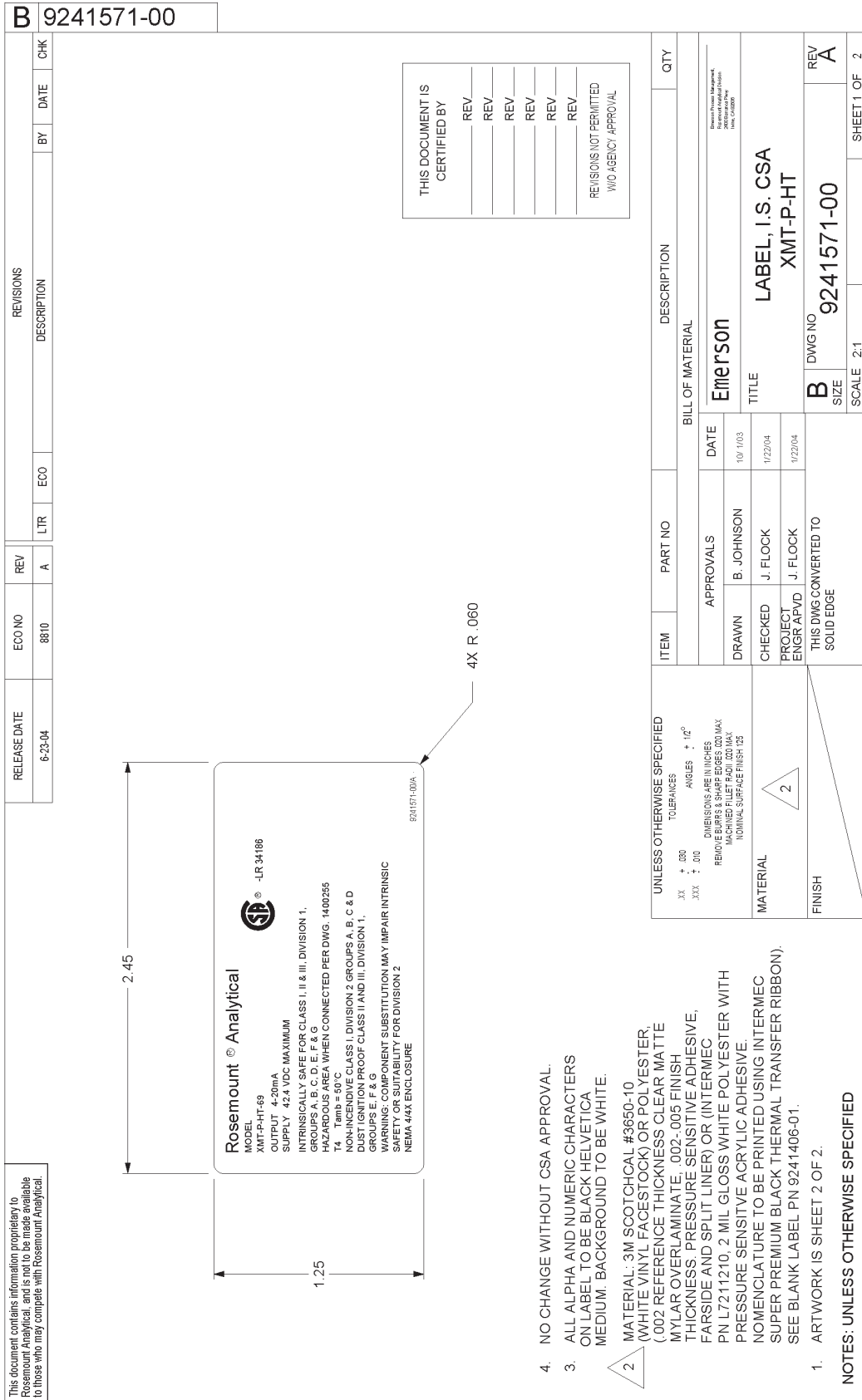

FIGURE 8. CSA Intrinsically Safe Installation Label

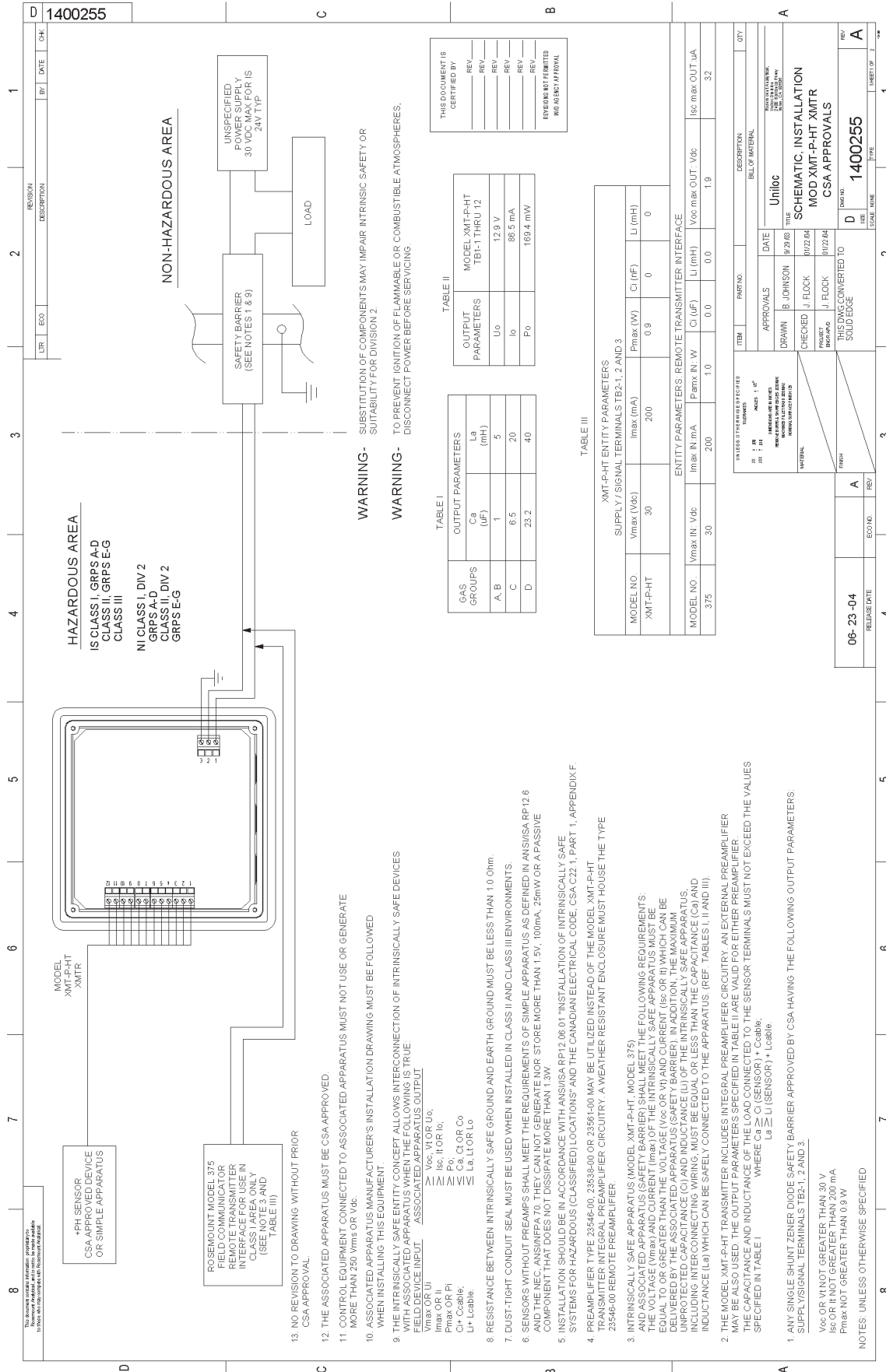

FIGURE 9. CSA Intrinsically Safe Installation Wiring (1 of 2)

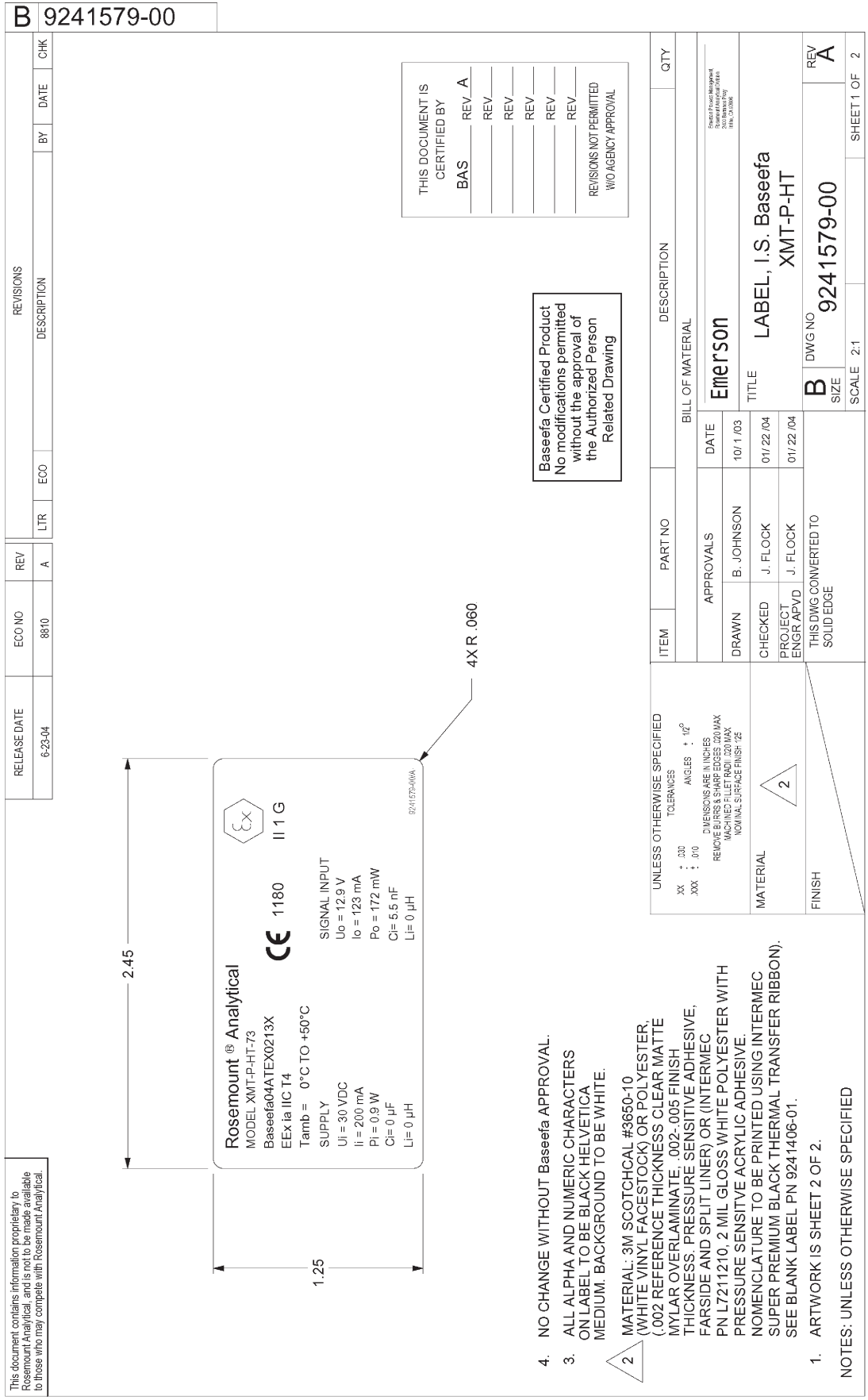

FIGURE 10. Baseefa/ATEX Intrinsically Safe Installation label

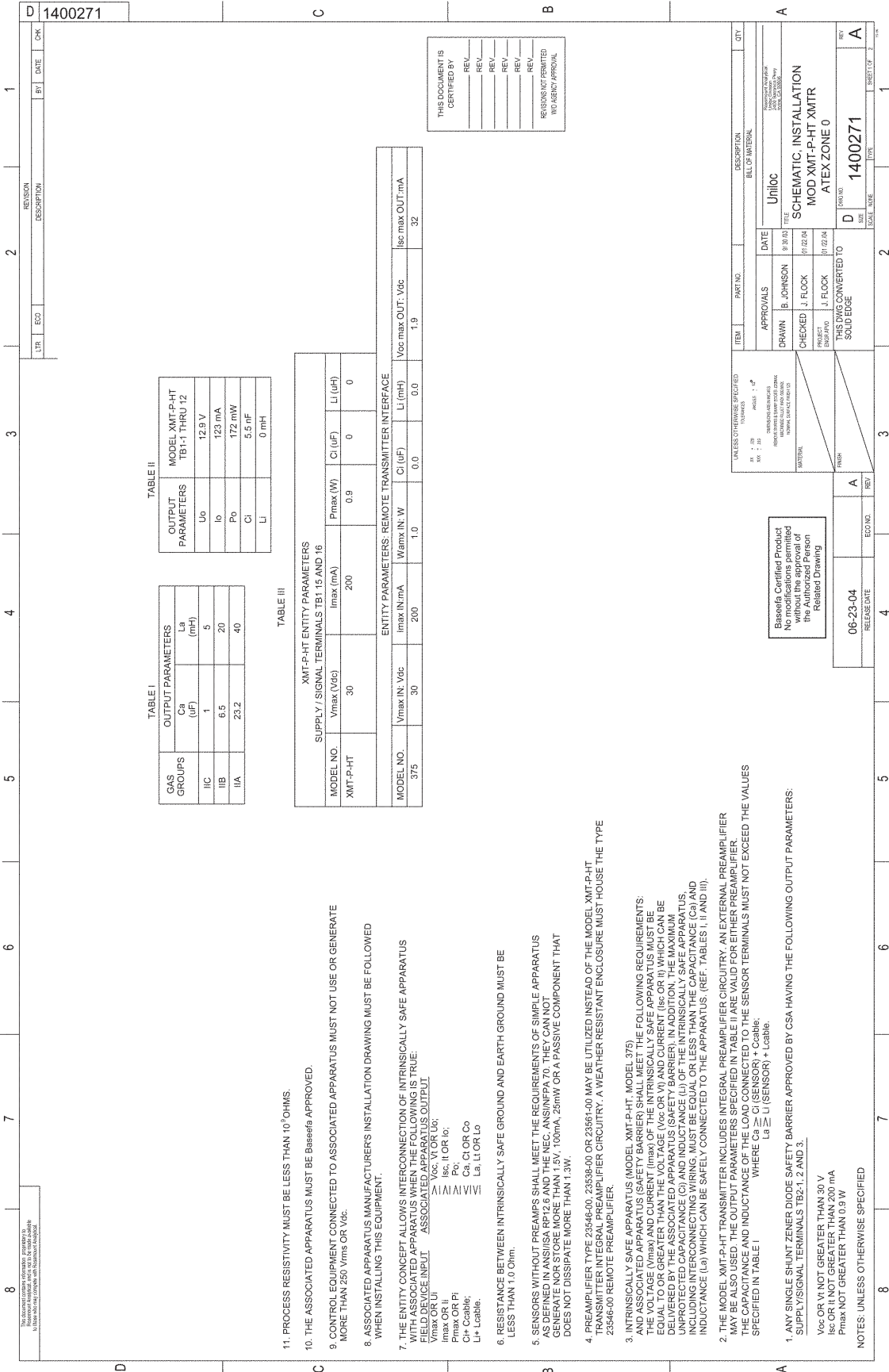

FIGURE 11. Baseefa/ATEX Intrinsically Safe Installation Wiring (1 of 2)

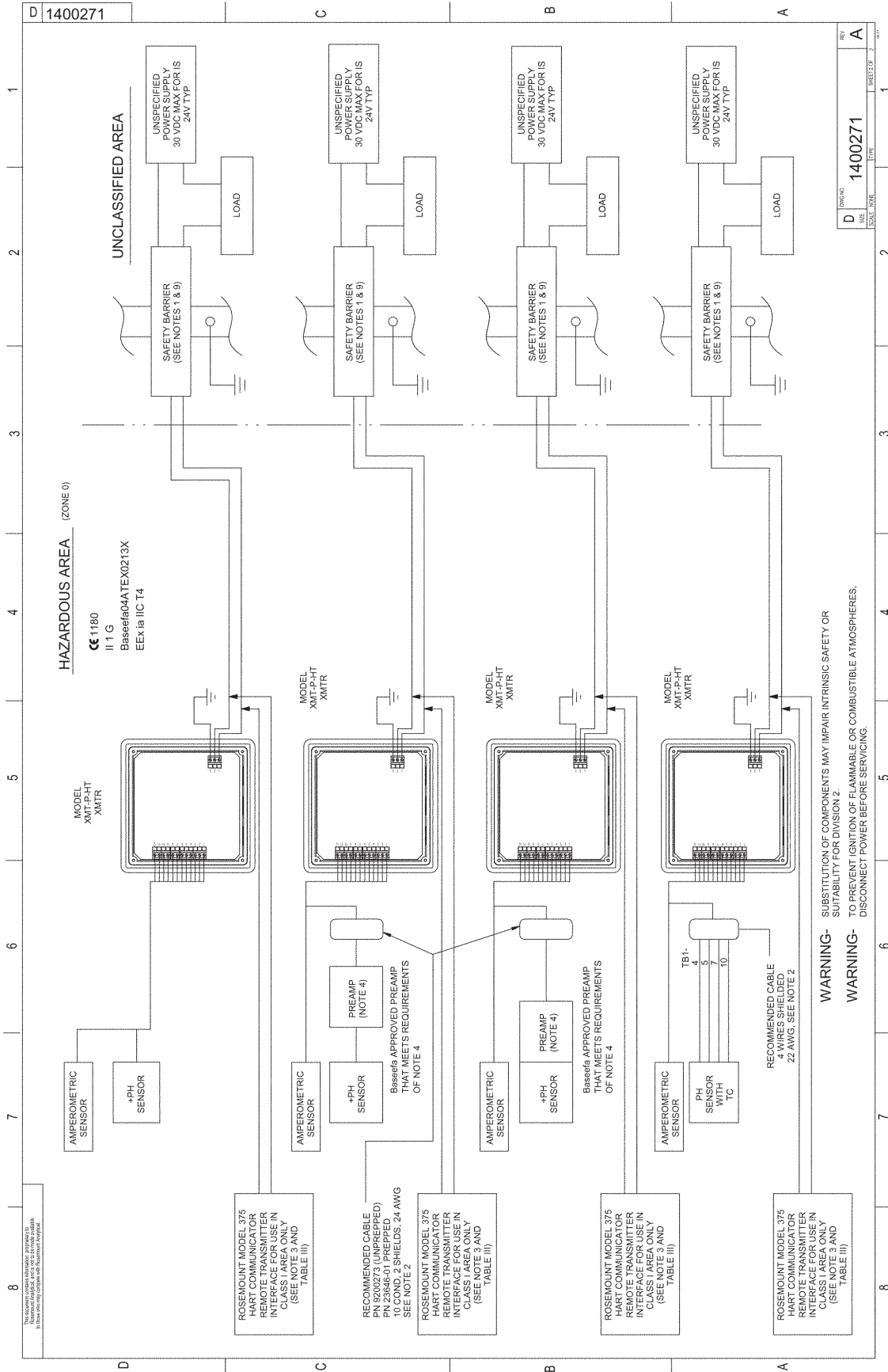
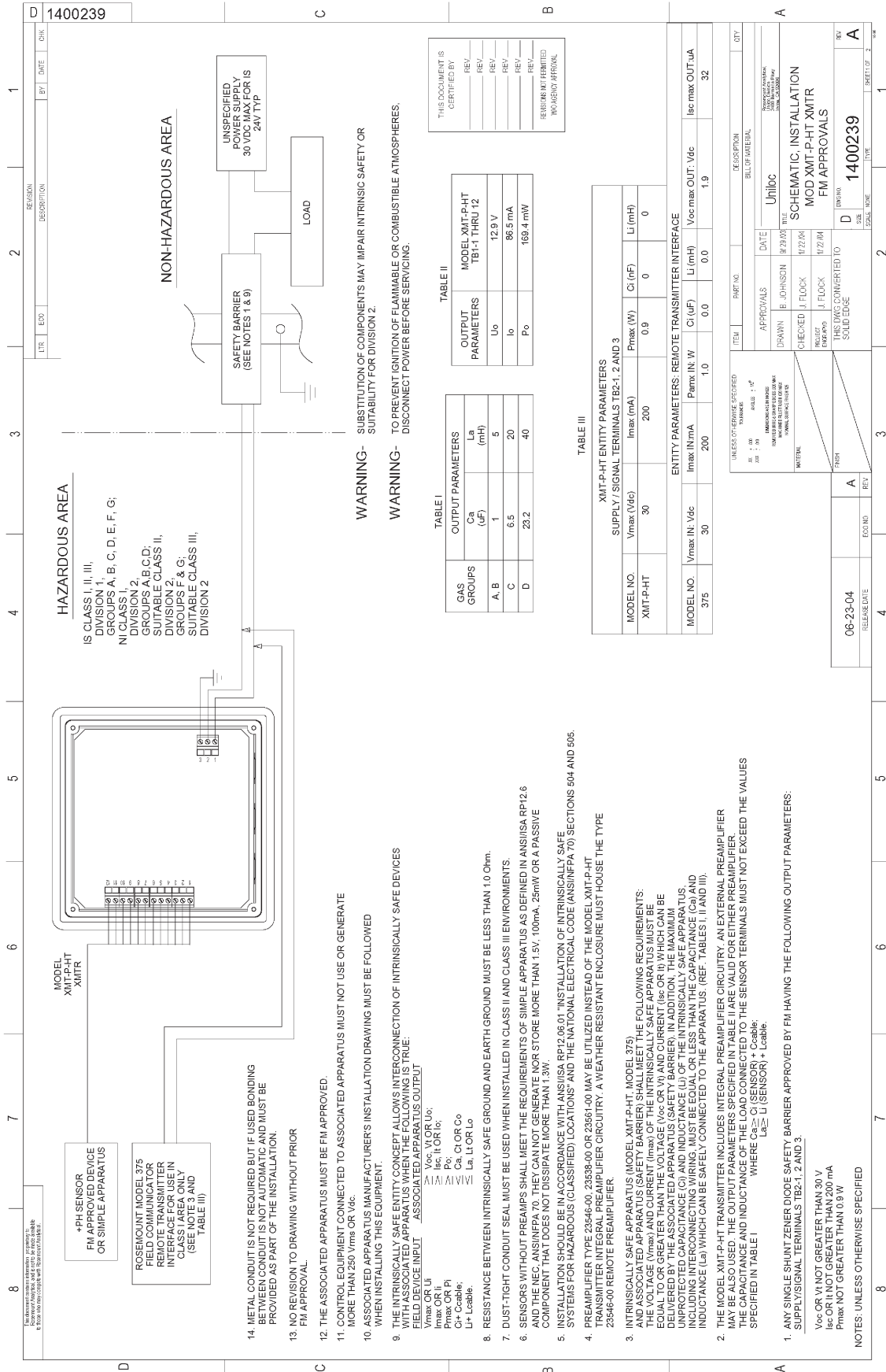

FIGURE 11. Baseefa/ATEX Intrinsically Safe Installation Wiring (2 of 2)



REV	DATE	BY	CHK
1			

DESCRIPTION	DATE
1400239	

ITEM	DESCRIPTION	QTY
1	UNSPECIFIED PNEUMATICALLY OPERATED 30 VDC MAX FOR IS 24V Typ	1

ITEM	DESCRIPTION	QTY
2	SAFETY BARRIER (SEE NOTES 1 & 9)	1

ITEM	DESCRIPTION	QTY
3	LOAD	1

ITEM	DESCRIPTION	QTY
4	HAZARDOUS AREA	1

ITEM	DESCRIPTION	QTY
5	NON-HAZARDOUS AREA	1

ITEM	DESCRIPTION	QTY
6	MODEL XMT-P-HT	1

ITEM	DESCRIPTION	QTY
7	ROSEMOUNT MODEL 375	1

ITEM	DESCRIPTION	QTY
8	SAFETY BARRIER (SEE NOTES 1 & 9)	1

ITEM	DESCRIPTION	QTY
9	LOAD	1

ITEM	DESCRIPTION	QTY
10	HAZARDOUS AREA	1

ITEM	DESCRIPTION	QTY
11	NON-HAZARDOUS AREA	1

ITEM	DESCRIPTION	QTY
12	MODEL XMT-P-HT	1

ITEM	DESCRIPTION	QTY
13	ROSEMOUNT MODEL 375	1

ITEM	DESCRIPTION	QTY
14	SAFETY BARRIER (SEE NOTES 1 & 9)	1

ITEM	DESCRIPTION	QTY
15	LOAD	1

ITEM	DESCRIPTION	QTY
16	HAZARDOUS AREA	1

ITEM	DESCRIPTION	QTY
17	NON-HAZARDOUS AREA	1

ITEM	DESCRIPTION	QTY
18	MODEL XMT-P-HT	1

ITEM	DESCRIPTION	QTY
19	ROSEMOUNT MODEL 375	1

ITEM	DESCRIPTION	QTY
20	SAFETY BARRIER (SEE NOTES 1 & 9)	1

ITEM	DESCRIPTION	QTY
21	LOAD	1

ITEM	DESCRIPTION	QTY
22	HAZARDOUS AREA	1

ITEM	DESCRIPTION	QTY
23	NON-HAZARDOUS AREA	1

ITEM	DESCRIPTION	QTY
24	MODEL XMT-P-HT	1

ITEM	DESCRIPTION	QTY
25	ROSEMOUNT MODEL 375	1

ITEM	DESCRIPTION	QTY
26	SAFETY BARRIER (SEE NOTES 1 & 9)	1

ITEM	DESCRIPTION	QTY
27	LOAD	1

ITEM	DESCRIPTION	QTY
28	HAZARDOUS AREA	1

ITEM	DESCRIPTION	QTY
29	NON-HAZARDOUS AREA	1

ITEM	DESCRIPTION	QTY
30	MODEL XMT-P-HT	1

ITEM	DESCRIPTION	QTY
31	ROSEMOUNT MODEL 375	1

ITEM	DESCRIPTION	QTY
32	SAFETY BARRIER (SEE NOTES 1 & 9)	1

ITEM	DESCRIPTION	QTY
33	LOAD	1

ITEM	DESCRIPTION	QTY
34	HAZARDOUS AREA	1

ITEM	DESCRIPTION	QTY
35	NON-HAZARDOUS AREA	1

ITEM	DESCRIPTION	QTY
36	MODEL XMT-P-HT	1

ITEM	DESCRIPTION	QTY
37	ROSEMOUNT MODEL 375	1

ITEM	DESCRIPTION	QTY
38	SAFETY BARRIER (SEE NOTES 1 & 9)	1

ITEM	DESCRIPTION	QTY
39	LOAD	1

ITEM	DESCRIPTION	QTY
40	HAZARDOUS AREA	1

ITEM	DESCRIPTION	QTY
41	NON-HAZARDOUS AREA	1

ITEM	DESCRIPTION	QTY
42	MODEL XMT-P-HT	1

ITEM	DESCRIPTION	QTY
43	ROSEMOUNT MODEL 375	1

ITEM	DESCRIPTION	QTY
44	SAFETY BARRIER (SEE NOTES 1 & 9)	1

ITEM	DESCRIPTION	QTY
45	LOAD	1

ITEM	DESCRIPTION	QTY
46	HAZARDOUS AREA	1

ITEM	DESCRIPTION	QTY
47	NON-HAZARDOUS AREA	1

ITEM	DESCRIPTION	QTY
48	MODEL XMT-P-HT	1

ITEM	DESCRIPTION	QTY
49	ROSEMOUNT MODEL 375	1

ITEM	DESCRIPTION	QTY
50	SAFETY BARRIER (SEE NOTES 1 & 9)	1

ITEM	DESCRIPTION	QTY
51	LOAD	1

ITEM	DESCRIPTION	QTY
52	HAZARDOUS AREA	1

ITEM	DESCRIPTION	QTY
53	NON-HAZARDOUS AREA	1

ITEM	DESCRIPTION	QTY
54	MODEL XMT-P-HT	1

ITEM	DESCRIPTION	QTY
55	ROSEMOUNT MODEL 375	1

ITEM	DESCRIPTION	QTY
56	SAFETY BARRIER (SEE NOTES 1 & 9)	1

ITEM	DESCRIPTION	QTY
57	LOAD	1

ITEM	DESCRIPTION	QTY
58	HAZARDOUS AREA	1

ITEM	DESCRIPTION	QTY
59	NON-HAZARDOUS AREA	1

ITEM	DESCRIPTION	QTY
60	MODEL XMT-P-HT	1

ITEM	DESCRIPTION	QTY
61	ROSEMOUNT MODEL 375	1

ITEM	DESCRIPTION	QTY
62	SAFETY BARRIER (SEE NOTES 1 & 9)	1

ITEM	DESCRIPTION	QTY
63	LOAD	1

ITEM	DESCRIPTION	QTY
64	HAZARDOUS AREA	1

ITEM	DESCRIPTION	QTY
65	NON-HAZARDOUS AREA	1

ITEM	DESCRIPTION	QTY
66	MODEL XMT-P-HT	1

ITEM	DESCRIPTION	QTY
67	ROSEMOUNT MODEL 375	1

ITEM	DESCRIPTION	QTY
68	SAFETY BARRIER (SEE NOTES 1 & 9)	1

ITEM	DESCRIPTION	QTY
69	LOAD	1

ITEM	DESCRIPTION	QTY
70	HAZARDOUS AREA	1

ITEM	DESCRIPTION	QTY
71	NON-HAZARDOUS AREA	1

ITEM	DESCRIPTION	QTY
72	MODEL XMT-P-HT	1

ITEM	DESCRIPTION	QTY
73	ROSEMOUNT MODEL 375	1

ITEM	DESCRIPTION	QTY
74	SAFETY BARRIER (SEE NOTES 1 & 9)	1

ITEM	DESCRIPTION	QTY
75	LOAD	1

ITEM	DESCRIPTION	QTY
76	HAZARDOUS AREA	1

ITEM	DESCRIPTION	QTY
77	NON-HAZARDOUS AREA	1

ITEM	DESCRIPTION	QTY
78	MODEL XMT-P-HT	1

ITEM	DESCRIPTION	QTY
79	ROSEMOUNT MODEL 375	1

ITEM	DESCRIPTION	QTY
80	SAFETY BARRIER (SEE NOTES 1 & 9)	1

ITEM	DESCRIPTION	QTY
81	LOAD	1

ITEM	DESCRIPTION	QTY
82	HAZARDOUS AREA	1

ITEM	DESCRIPTION	QTY
83	NON-HAZARDOUS AREA	1

ITEM	DESCRIPTION	QTY
84	MODEL XMT-P-HT	1

ITEM	DESCRIPTION	QTY
85	ROSEMOUNT MODEL 375	1

ITEM	DESCRIPTION	QTY
86	SAFETY BARRIER (SEE NOTES 1 & 9)	1

ITEM	DESCRIPTION	QTY
87	LOAD	1

ITEM	DESCRIPTION	QTY
88	HAZARDOUS AREA	1

ITEM	DESCRIPTION	QTY
89	NON-HAZARDOUS AREA	1

ITEM	DESCRIPTION	QTY
90	MODEL XMT-P-HT	1

ITEM	DESCRIPTION	QTY
91	ROSEMOUNT MODEL 375	1

ITEM	DESCRIPTION	QTY
92	SAFETY BARRIER (SEE NOTES 1 & 9)	1

ITEM	DESCRIPTION	QTY
93	LOAD	1

ITEM	DESCRIPTION	QTY
94	HAZARDOUS AREA	1

ITEM	DESCRIPTION	QTY
95	NON-HAZARDOUS AREA	1

ITEM	DESCRIPTION	QTY
96	MODEL XMT-P-HT	1

ITEM	DESCRIPTION	QTY
97	ROSEMOUNT MODEL 375	1

ITEM	DESCRIPTION	QTY
98	SAFETY BARRIER (SEE NOTES 1 & 9)	1

ITEM	DESCRIPTION	QTY
99	LOAD	1

ITEM	DESCRIPTION	QTY
100	HAZARDOUS AREA	1

ITEM	DESCRIPTION	QTY
101	NON-HAZARDOUS AREA	1

ITEM	DESCRIPTION	QTY
102	MODEL XMT-P-HT	1

ITEM	DESCRIPTION	QTY
103	ROSEMOUNT MODEL 375	1

ITEM	DESCRIPTION	QTY
104	SAFETY BARRIER (SEE NOTES 1 & 9)	1

ITEM	DESCRIPTION	QTY
105	LOAD	1

ITEM	DESCRIPTION	QTY
106	HAZARDOUS AREA	1

ITEM	DESCRIPTION	QTY
107	NON-HAZARDOUS AREA	1

ITEM	DESCRIPTION	QTY
108	MODEL XMT-P-HT	1

ITEM	DESCRIPTION	QTY
109	ROSEMOUNT MODEL 375	1

ITEM	DESCRIPTION	QTY
110	SAFETY BARRIER (SEE NOTES 1 & 9)	1

ITEM	DESCRIPTION	QTY
111	LOAD	1

ITEM	DESCRIPTION	QTY
112		

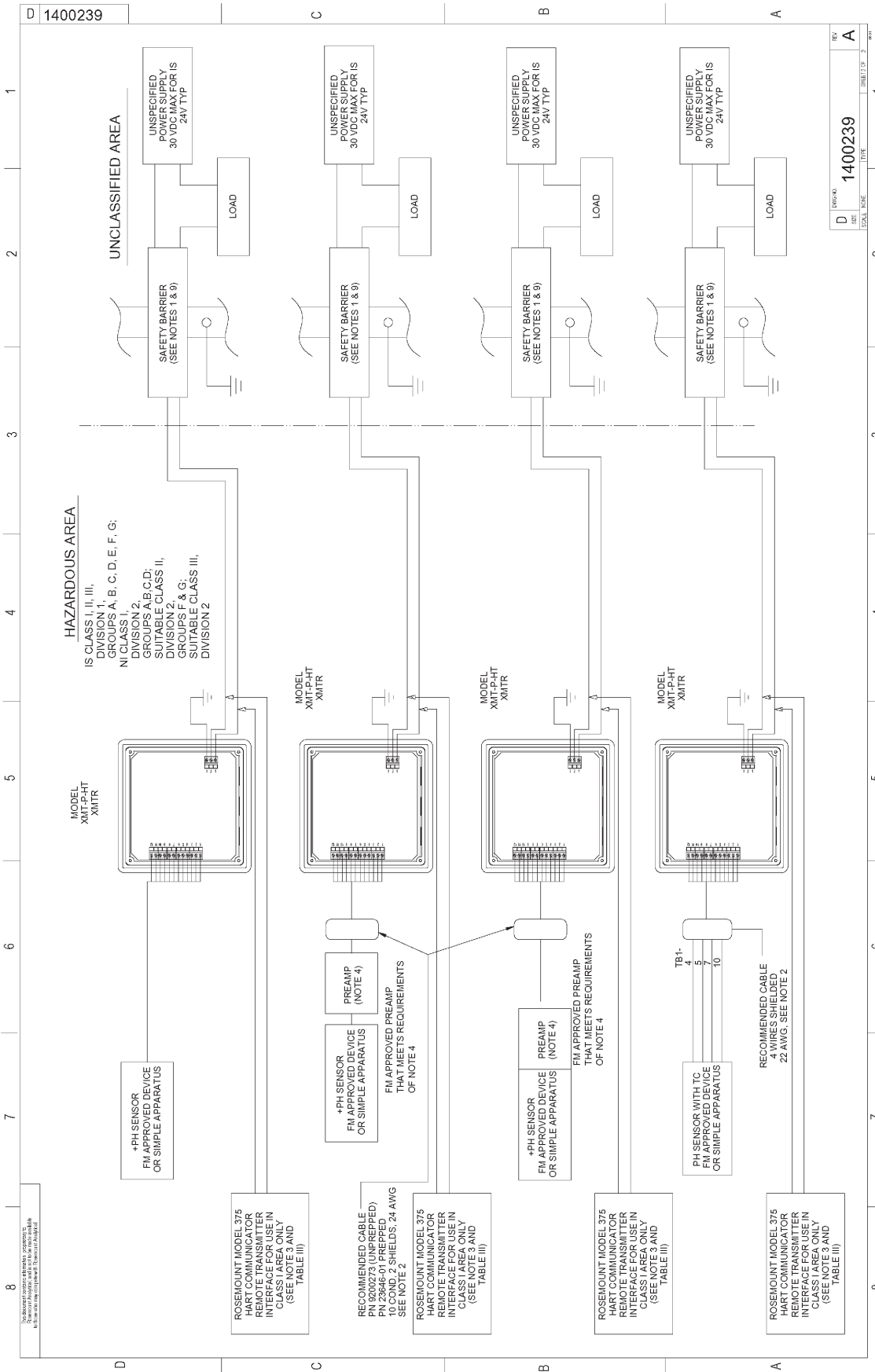
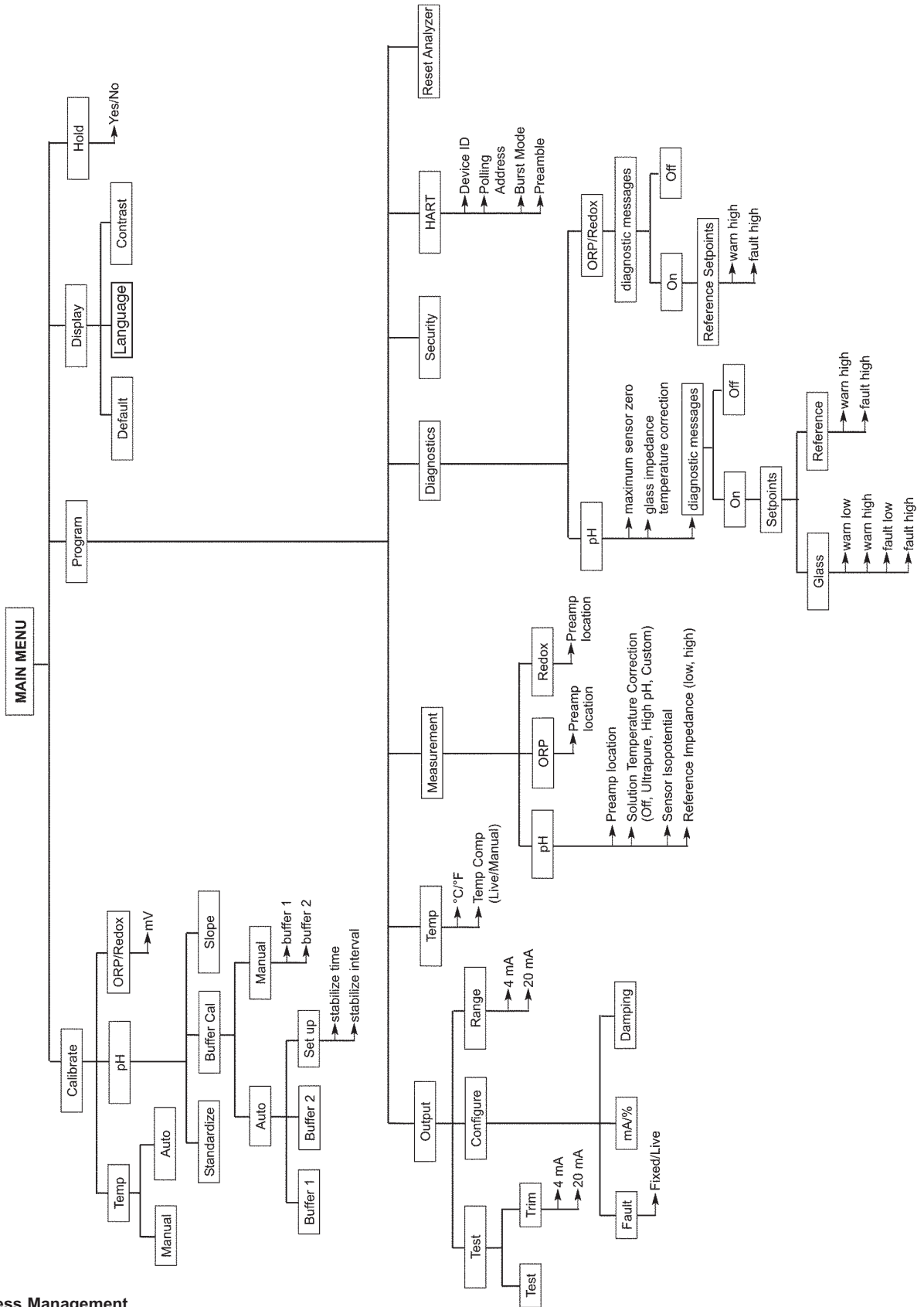

FIGURE 13. FM Intrinsically Safe Installation Wiring (2 of 2)

MAIN MENU

MENU TREE FOR MODEL SOLU COMP Xmt-P-HT TRANSMITTER



Emerson Process Management

2400 Barranca Parkway
Irvine, CA 92606 USA
Tel: (949) 757-8500
Fax: (949) 474-7250

<http://www.raihome.com>

© Rosemount Analytical Inc. 2010

