

Four-electrode Conductivity Sensor

For additional information, please refer to the Instruction Manuals CD shipped with this product, or visit our website at www.emersonprocess.com/raihome/liquid/.

CAUTION

SENSOR/PROCESS APPLICATION COMPATIBILITY

The wetted sensor materials may not be compatible with process composition and operating conditions. Application compatibility is entirely the responsibility of the user.

CAUTION



Before removing the sensor, be absolutely certain that the process pressure is reduced to 0 psig and the process temperature is lowered to a safe level!

SENSOR SPECIFICATIONS

Pressure and Temperature:

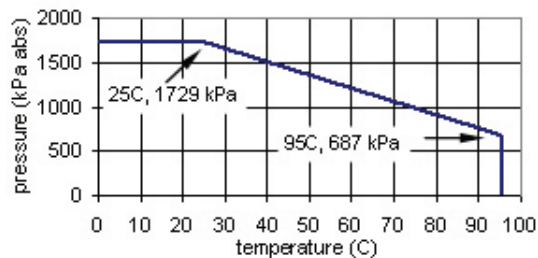
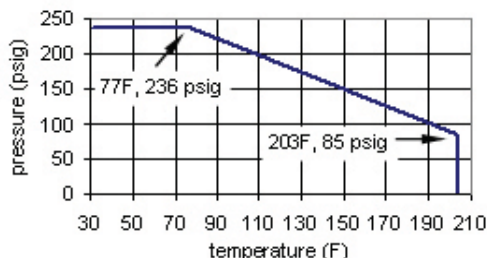

Wetted materials: Unfilled PEEK, 316L stainless steel, EP (option 22 only). PEEK meets 21CFR177.2415. EP meets 21CFR177.2600.

Surface finish: 16 microinch (0.4 micron) Ra (except electrode surfaces)

Steam sterilization: tolerates SIP to 284°F (140°C)

INSTALLATION

The 410VP sensor is available with four process connections: 1½ inch Tri-Clamp¹, 2-inch Tri-Clamp, G 1¼, and Varivent N². Gaskets and clamps for the Tri-Clamp and Varivent connections must be supplied by the user.

Install the sensor so that the electrodes are completely immersed in the process liquid. Avoid installing the sensor in places where air bubbles are likely to get trapped or sediment is likely to accumulate on the electrodes. Generally, mounting the sensor in a vertical pipe run is best. If the sensor must be installed in a horizontal pipe, place the sensor in the 3 o'clock position. Keep at least 0.5 inch (12 mm) clearance between the end of the sensor and the opposite pipe wall.

To keep response time as fast as possible, do not install the sensor in dead legs or areas where circulation is poor.

¹Tri-Clamp is a registered trademark of Alfa Laval, Inc.

²Varivent is a registered trademark of Tuchemhagen, GmbH.

WIRING

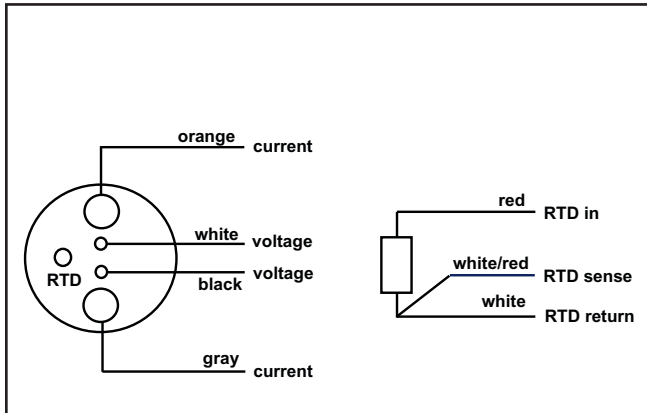

Figure 1. Wire color and functions. Current is injected through the gray and orange wires. Voltage is measured across the white and black wires.

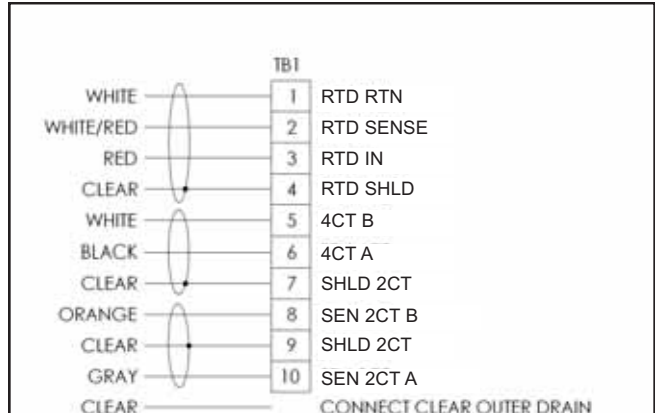

Figure 2. Model 1056 and Model 56 wiring.

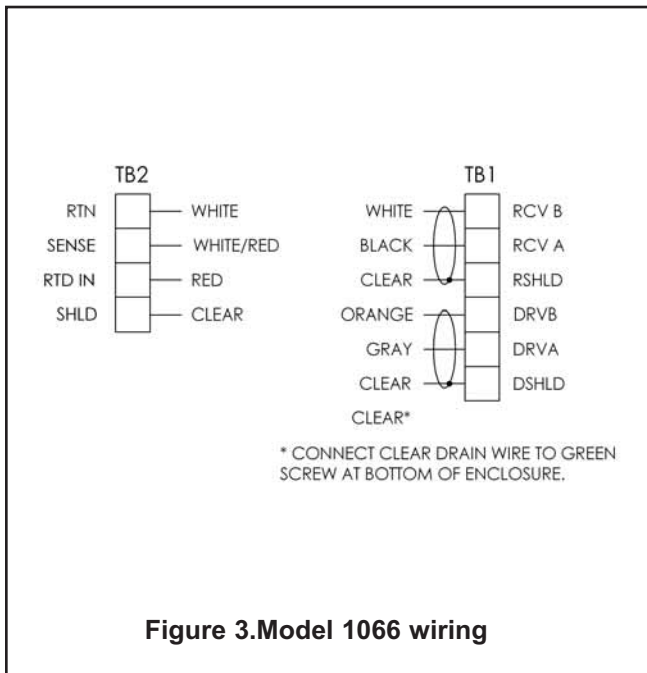

Figure 3. Model 1066 wiring

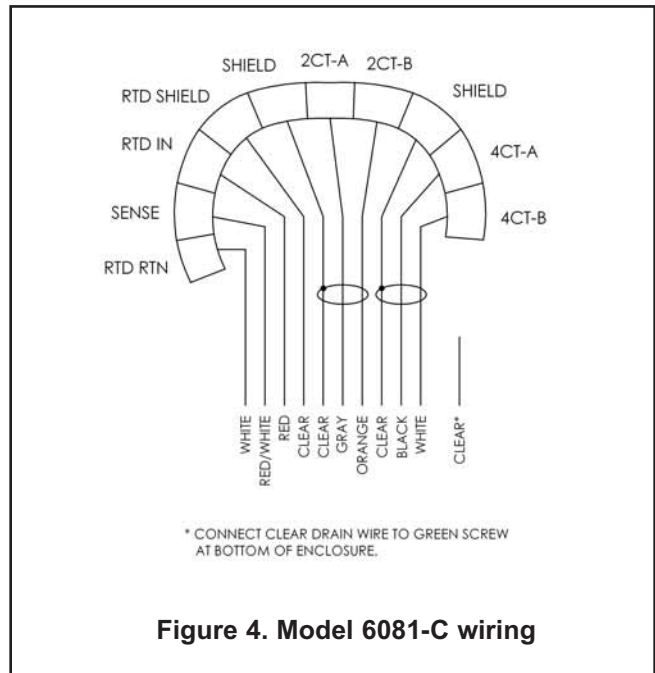

Figure 4. Model 6081-C wiring

The terminal end of the sensor is keyed to ensure proper mating with the cable receptacle. Once the key has slid into the mating slot, tighten the connection by turning the knurled ring clockwise.

SETUP AND CALIBRATION

The sensor is calibrated at the factory and does not require initial user-calibration. Simply configure the analyzer to accept a four-electrode sensor and enter the cell constant and calibration factor printed on the label.

After a period of service, the sensor may require calibration. The sensor can be calibrated against a solution having known conductivity or against a referee meter and sensor. If using a standard solution, choose one having conductivity greater than 500 $\mu\text{S}/\text{cm}$. Do not use standard solutions having conductivity less than 100 $\mu\text{S}/\text{cm}$. They are susceptible to contamination by atmospheric carbon dioxide, which can alter the conductivity by a variable amount as great as 1.2 $\mu\text{S}/\text{cm}$ (at 25°C). Calibration changes the cell constant only, not the calibration factor. For more information about calibrating contacting conductivity sensors see application sheet ADS 43-024 available on the Rosemount Analytical website.

TROUBLESHOOTING

PROBLEM	PROBABLE CAUSE	SOLUTION
Off-scale reading	Wiring is incorrect.	Verify wiring.
	RTD is open or shorted.	Check RTD for open connections or shorts. See Figure 1.
	Sensor is not in process stream.	Be sure sensor is completely submerged in process stream.
	Variopol cable is not properly seated.	Loosen connector and reseal.
Noisy reading	Sensor is improperly installed in process stream.	Be sure sensor is completely submerged in process stream.
	Variopol cable is not properly seated.	Loosen connector and reseal.
Reading seems wrong (lower or higher than expected)	Bubbles trapped on sensor.	Be sure sensor is installed so that air cannot become trapped against it.
	Wrong temperature correction algorithm.	Check that temperature correction algorithm is appropriate for the sample. See the analyzer manual for more information.
	Wrong cell constant. Wrong calibration factor.	Verify that the correct cell constant and calibration factor have been entered in the analyzer. See the analyzer manual for more information.
	Bottom of sensor is too close to pipe wall.	Maintain at least 0.5 in (12 mm) clearance between bottom of sensor and opposite pipe wall.
	Temperature reading in error	Disconnect red and white RTD wires. Measure resistance across leads, which should be about 1100 Ω at room temperature.
Sluggish response	Electrodes are fouled.	Clean electrodes.
	Sensor is installed in dead area in process piping	Move sensor to a location more representative of the process liquid.



*The right people,
the right answers,
right now.*

**ROSEMOUNT ANALYTICAL
CUSTOMER SUPPORT CENTER
1-800-854-8257**



Credit Cards for U.S. Purchases Only.



ON-LINE ORDERING NOW AVAILABLE ON OUR WEB SITE
<http://www.raihome.com>

Specifications subject to change without notice.

Emerson Process Management

2400 Barranca Parkway
Irvine, CA 92606 USA
Tel: (949) 757-8500
Fax: (949) 474-7250

<http://www.raihome.com>

