

# Process Gas Chromatograph

The Model 500 Process Gas Chromatograph is an advanced combination of technology and rugged instrumentation that helps make the most of existing plant manpower. Today's trend toward downsizing means instrument technicians have more to do in less time. Instrumentation has to be more reliable and easier to use than ever before. Emerson's Rosemount Analytical Process Gas Chromatographs are your best choice; we've built our reputation on equipment reliability and long-term performance combined with ease of use.



## FEATURES

- Proven performance with thousands of units installed around the globe
- Isothermal analysis with 1 or 2 thermal conductivity detectors / heat-sink airless ovens
- Fully compatible with modern Ethernet networks and DCS communication
- Designed for field mounting without the need for expensive analyzer shelters or sacrificing analytical power
- Diaphragm-based 6-port chromatograph valves
- Liquid and gas analysis in a single unit
- Thermal Conductivity Detector (TCD) sensitive down to very low parts-per-million levels.
- Flame Photometric Detector (FPD) also available
- Every Model 500 is rigorously tested in an environmental chamber between 0° to 130°F for 24 hours minimum
- Last chromatogram for each sample and calibration stream stored in process gas chromatograph
- Archives up to 64 item averages, up to 35 days of standard runs and calculations

## APPLICATIONS

The Model 500 is designed for a variety of refining, petrochemical, power and environmental applications where selected components in gaseous or liquid streams must be precisely monitored on a continuous basis.

### Refineries

- Catalytic reformer
- Isomerization unit
- Aromatics unit

### Petrochemical

- Ethylene plants
- Polymer plants
- Acrylonitrile plants

### Gas Processing

- NGL, GTL, and LNG plants
- Cryogenic gas plants

### Power Generation

- Power generation plants
- Gas turbine control

### Environmental Monitoring

- Ambient air monitoring
- HR-VOCs in flares and cooling towers

## The Rosemount Analytical Process Gas Chromatograph Difference

- Broad application scope with single- or dual- detector capability
- Extreme ambient temperature operation minimizes installation and utility requirements
- High-sensitivity thermal conductivity detectors can often replace the need for more complex detectors
- Easy-to-use MON2000™ software for advanced diagnostics and simplified troubleshooting is simply the best in the industry
- Rosemount Analytical diaphragm valves offer a lifetime warranty

**ROSEMOUNT®**  
Analytical

Visit our website at [www.raihome.com](http://www.raihome.com)  
Online ordering available.

  
**EMERSON**  
Process Management

## Gas Chromatograph Valves

The chromatograph valves used in Rosemount Analytical Process Gas Chromatographs are unique to the online gas chromatograph market. Using a design originally developed by NASA, the valve offers greatly extended operating life. Emerson Process Management is currently the only on-line gas chromatograph supplier to offer a lifetime warranty on their Rosemount Analytical chromatograph valves!

- Simple mechanical design
- Sample does not come in contact with internal moving parts
- More than 5 million operations per valve
- Lifetime warranty
- Rotary liquid injection valves also available for special applications

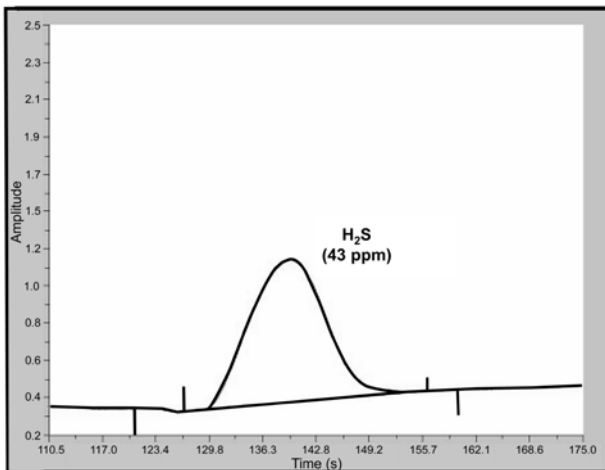

***For many part-per-million applications, a simple easy-to-maintain TCD detector can be used rather than a more complicated FID or FPD due to the superior sensitivity of the Rosemount Analytical TCD design.***



The reason for the exceptional durability of the valve is its unique double-diaphragm actuation. The double-diaphragm design eliminates the need for springs, o-rings, and lubrication. Flow paths in the valve are arranged so that internal moving parts never contact the sample flow. As a result, abrasive mechanical wear on machined valve surfaces is eliminated. The valves are rated for over five million operations before repair (approximately 3-5 years of usage). Then, repair is typically simply changing the diaphragms in the valve.

Most importantly, the Rosemount Analytical valve offers excellent performance. Minimal internal movement of the components in the valve — roughly 1/1000th of an inch — contributes to rapid actuation of the valve, which can be important for applications using micro-packed and capillary columns.



***The diaphragm valve used in the Model 500 is so reliable, it comes with a lifetime warranty***

## Detectors

The Model 500 Process Gas Chromatograph has the selection of detectors to handle the wide range of analytical demands found in typical process applications. Whether the components of interest are in the percent range or down to the parts-per-million range, precise and reliable measurements are possible.

- Thermal conductivity detector (TCD) detector is sensitive down to 3 ppm
- Dual TCD / TCD configuration possible
- Flame photometric detector (FPD) module also available

The TCD thermistor is the detector of choice for most applications due to its universal response to all compounds. Emerson's Rosemount Analytical TCD is able to go well beyond the normal measuring ranges seen in other designs by being able to do many

applications with low parts-per-million measurement requirements. This greatly simplifies the process gas chromatograph design when a simple and rugged TCD can be used rather than a FID.

## Heat Sink Oven

The heat sink oven design of the Model 500 brings stable and precise measurement to the field without the need for expensive analyzer shelters.

- Airless heat sink oven with operating temperatures up to 185°F (85°C)
- Up to three 6-port diaphragm valves for maximum analytical flexibility
- Micro-packed columns mounted in the center of the heat sink oven for stable performance over the analyzer's entire ambient temperature rating

Installed in thousands of units worldwide, the heat sink oven integrates TCDs, micro-packed columns, and chromatograph valves in a single temperature-controlled assembly. The entire oven is certified for operation without the need for instrument air — for oven heat or for safety reasons.

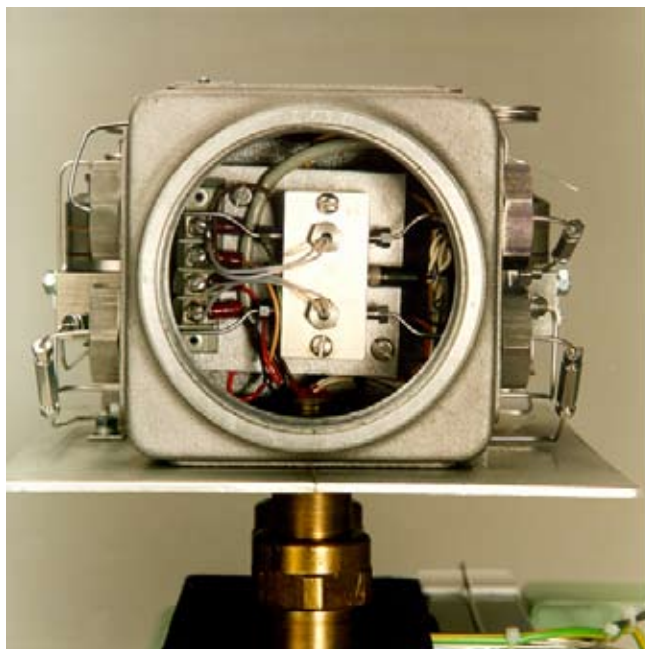

*Maintenance of the Model 500 heat sink oven is simplified with all components mounted on the surface of the oven with convenient access to all analytical components including valves, columns, and detectors.*

## Columns

Rosemount Analytical micro-packed columns offer a superior combination of the features found in both capillary and conventional packed columns. The result is improved chromatography with extended column life (several years in most applications without measurable degradation or bleed). Rosemount Analytical micro-packed columns produce sharper peaks for improved component separation, short analysis time, and very low carrier-gas consumption.

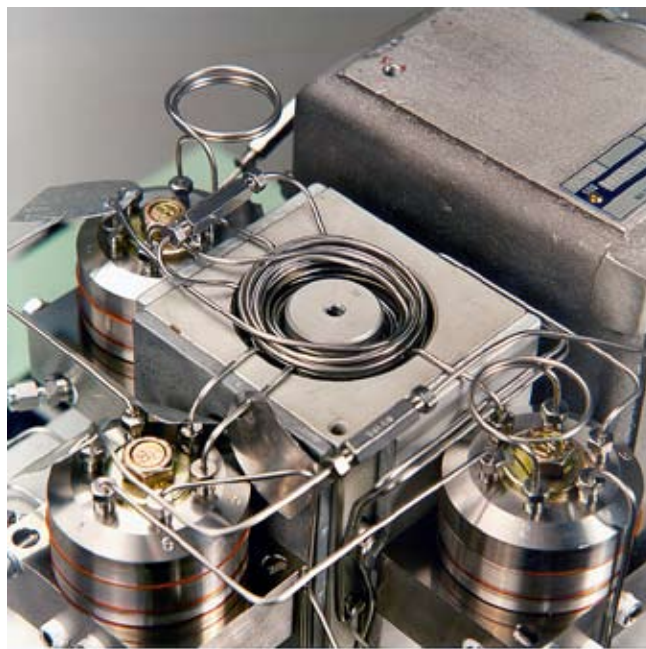

### The Design Makes The Difference:

- Built tough to stand up against any environment
- Tested tough to insure performance
- Field-mountable technology means solid performance at reduced cost
- Valves built so well, they're guaranteed for life
- Detector options that meet your requirements
- Micro-packed columns that are made to last

## MON2000™ Software

The Model 500 Process Gas Chromatograph is designed to operate unattended. If, however, adjustments are needed, our exclusive MON2000™ software allows complete control of your process gas chromatographs — either locally or remotely. From within MON2000, a user can:

- Review and modify analytical settings
- Upload and display multiple chromatograms on the screen for comparison
- Upload and trend any of the measured results
- Export data for use in other third-party applications
- Overlay multiple chromatograms for troubleshooting and calibration
- Check original calibration against last calibration

The MON2000 Software is Windows®-based software designed to make analyzer configuration, maintenance and data collection easy. With intuitive drop-down menus and fill-in-the-blank tables, even new users can quickly navigate through the software.

The MON2000 software can display both current and multiple archived chromatograms on the screen streamlining the time needed to perform routine analyzer maintenance.

MON2000 also has a number of tools built in that help users manage their analyzers such as:

- Automatic recording of alarms in a log file
- Event logs that provide a continuous record of all operator changes with time and user name stored
- Maintenance log scratch pad for keeping track of maintenance or testing done

Data collected from the process gas chromatographs can be stored and displayed with a wide range of options such as trend lines on the screen and logs automatically documenting all changes made to the process gas chromatograph. Data can also be exported in formats compatible with most third-party Windows® applications.

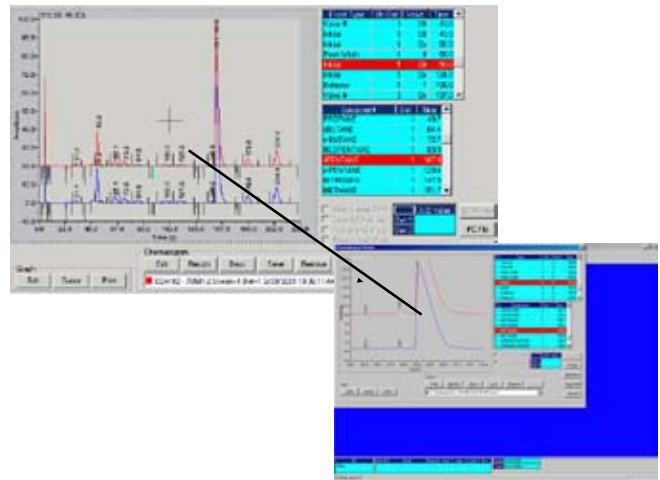

Comparing multiple chromatograms and zooming into specific sections is easy with the point and click design of MON2000™.

## Powerful Yet Simple – MON2000 Software

The figure shows a screenshot of the MON2000 software interface with several callouts pointing to specific features:

- Simple drop-down menus
- Connect to any GC with a mouse click
- Full featured chromatogram display
- Manually adjust X/Y scale
- Interactive cursor
- Display results
- Summary of application event status and time
- Automatic listing of measured components
- Quickly add chromatograms to overlay
- Save chromatograms to hard drive



## Environmental Chamber Testing

Emerson Process Management provides the most thorough process gas chromatograph testing in the world. Each Model 500 must operate to specification in our walk-in environmental test chambers cycling between 0°F and 130°F for 24 hours minimum. This is all part of our commitment to provide process gas chromatographs that are capable of providing reliable measurements in the field.

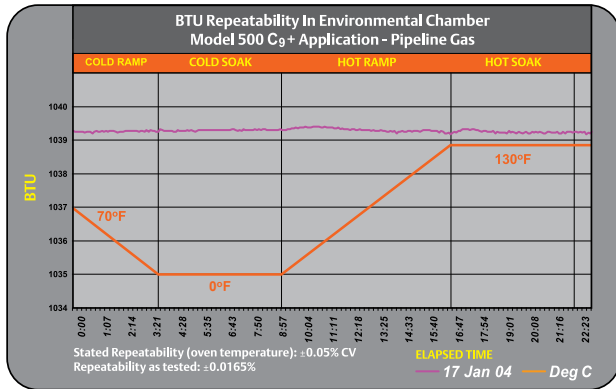

**Superior measurement stability in extreme climates is tested for every Model 500 Process Gas Chromatograph before it ships.**

## Custom Engineered Sample Systems

Any process gas chromatograph is only as good as the quality of the sample it measures. So every sample system for Rosemount Analytical Process Gas Chromatographs is custom engineered for the specific requirements of the application. Common features include:

- Heated and open panel designs
- All components rated for the area classification
- Automatic calibration / validation available as an option
- Variety of sample probes to extract a reliable and stable sample from the process

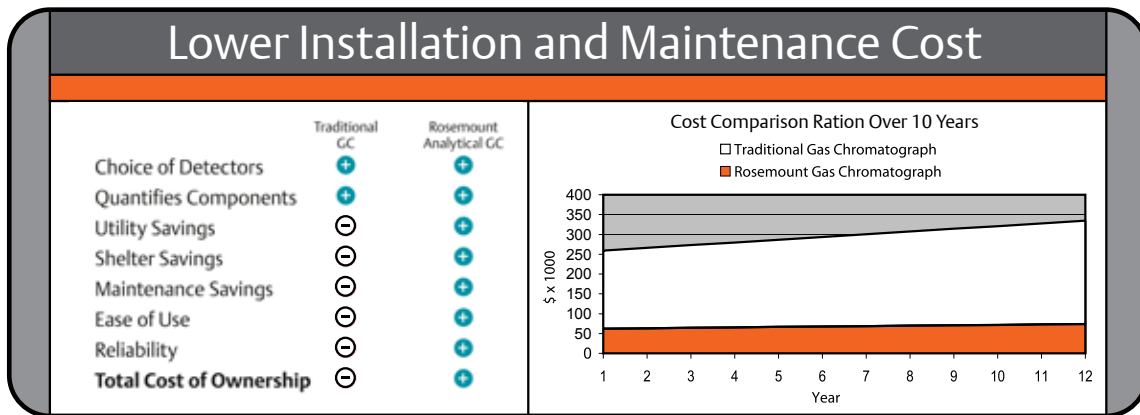

## Lower Installation and Maintenance Cost

Rosemount Analytical Process Gas Chromatographs offer some of the lowest cost of ownership in the industry. Most process measurements can be made at or near the sample point, greatly reducing the overall lifetime cost of the measurement. Expenses such as shelters, air conditioning, heating, long/heated sample lines can be minimized or completely eliminated in

most applications. Furthermore, Rosemount Analytical Process Gas Chromatographs are designed to operate unattended for long periods of time without adjustment. When adjustments are required, all components are easily accessible and can be performed in the field in minutes with standard tools.

**Request A Quotation**

Every Model 500 Process Gas Chromatograph is custom built for the specific application requested. To request a free quotation, simply fill out the information below and send it to the address at the end of this Data Sheet.



Name: \_\_\_\_\_  
 Title: \_\_\_\_\_  
 Company: \_\_\_\_\_  
 Address: \_\_\_\_\_  
 \_\_\_\_\_  
 \_\_\_\_\_  
 Phone #: \_\_\_\_\_  
 Fax #: \_\_\_\_\_  
 Email: \_\_\_\_\_

Your Reference #: \_\_\_\_\_  
 Project Name: \_\_\_\_\_  
 Process Unit: \_\_\_\_\_  
 Stream Name(s): \_\_\_\_\_  
 \_\_\_\_\_  
 Hazardous Area Classification: \_\_\_\_\_

Stream Composition	Units	Stream 1				Stream 2			
		Min	Normal	Max	Measure	Min	Normal	Max	Measure

*(For more than two streams, make copies of this page)*

	<b>Stream 1</b>	<b>Stream 2</b>
Stream Temperature:	_____	_____
Stream Pressure:	_____	_____
Stream Phase (vapor / liquid)	_____	_____
Stream Contaminants:	_____ _____ _____	_____ _____ _____
Distance to GC from Sample Point:	_____	_____
Mounting: Wall ( ) Pipe ( ) Stand ( )	Controller: Explosion-Proof ( )	19" Rack-Mount ( )
Data Communication: Analog Output ( ) Modbus ( ) OPC ( ) Printer ( ) Modem ( )		
Analyzer Network: Ethernet ( ) RS-485 Multi-Drop ( )	Power: 110 VAC ( )	230 VAC ( )
Other Options: Carrier Gas ( ) Calibration Gas ( ) Start-Up ( ) Training Class ( )		
CSA Version ( ) Tropicalization ( )		

Special Instructions: \_\_\_\_\_  
 \_\_\_\_\_  
 \_\_\_\_\_  
 \_\_\_\_\_

## MODEL 500 SPECIFICATIONS

**Power:** 115 VAC ±15%, 220 VAC ±15%, 50/60 HZ  
100 watts running, 350 watts start-up

**Environment:** -18° to 55°C (0° to 130°F)

**Enclosure Protection Rating:** NEMA 4

**Dimensions (without sample system):**

164cm H x 51cm W x 53.5cm D (64.5" H x 20" W x 21" D)

**Mounting:** Free-standing (standard); wall-mount (optional)

**Approximate Weight (without sample system):**

Approximately 36 kg. (79 lbs.)

**Area Safety Certification Options (hardware dependant):**

**Standard:** Designed to meet UL Class 1, Div. 1, Groups C, D (Group B with optional air purge)

**Optional CSA NRTL/C Certified:** Class I, Div. 1, Groups C, D, T3B

**Optional ATEX Certified:** EEx d IIB T4<sub>amb</sub> = 60°C  
CE marked per ATEX Directive (94/9/EC)

**Oven:** Airless heat sink, maximum 85°C (185°F)

**Valves:** 6-port and 10-port diaphragm chromatograph valves. Other types of valves may be used depending on the application such as liquid injection and rotary valves

**Carrier Gas:** Application dependent. Typically zero-grade helium, nitrogen, or hydrogen at 90 psig

**Detector:** Thermal conductivity detector (TCD); up to two depending on application. Flame photometric detector (FPD) available (see FPD Module data sheet)

**Gating Options:** Fixed-Time, Slope and Automatic gating of peaks

**Streams:** Up to 12 streams (including calibration stream)

**Chromatograph Control Electronics:** Mounted with the gas chromatograph in explosion-proof housing or remotely in 19" rack-mounting

**Analog Inputs:** Four inputs filtered with transient protection (note that the 4 inputs will be used by the second TCD)

**Analog Outputs:** Two outputs standard (up to 10 optional), 4-20 mA, non-isolated

**Serial Communication Ports:** Three serial ports standard with option for a total of eight. Depending on the port, choice of RS-232, RS-422 and RS-485 is available as well as the Modbus protocol

**Digital Inputs (optional):** One gas chromatograph alarm and five user assignable inputs, optically isolated with transient protection

**Digital Outputs (optional):** Five digital outputs can be used for alarms, optically isolated with transient protection

**Parallel Printer Port (optional):** One parallel port available for printed reports

**Internal Modem (optional):** Field-configurable; 300 to 19.2k baud

**Transient Protection:** C.E. tested and certified to the highest levels (3 and 4) of the European IEC 801 STD (3 Form C, 2 solid-state optically isolated)

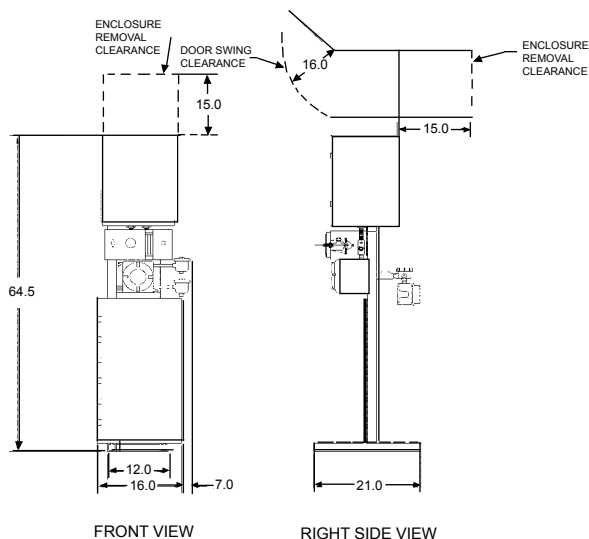

**Model 500 Single Oven Dimensional Drawing**

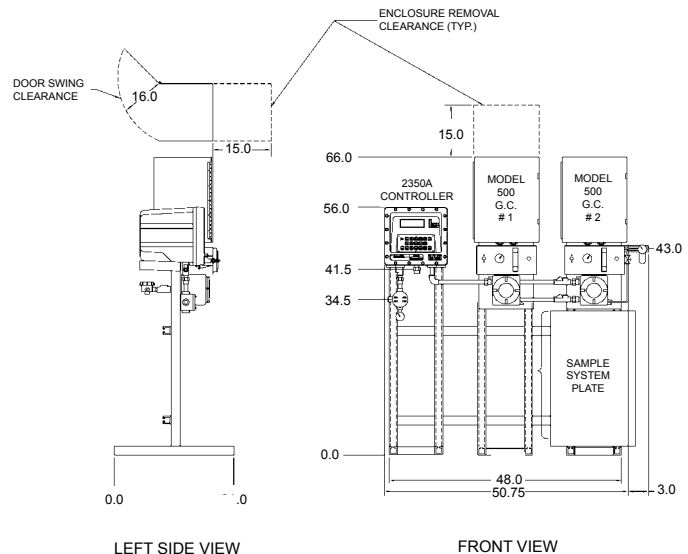

**Model 500 Dual Oven Dimensional Drawing**

*The contents of this publication are presented for informational purposes only, and while every effort has been made to ensure their accuracy, they are not to be construed as warranties or guarantees, express or implied, regarding the products or services described herein or their use or applicability. All sales are governed by our terms and conditions, which are available on request. We reserve the right to modify or improve the designs or specifications of our products at any time without notice.*

### Emerson Process Management

#### Rosemount Analytical Inc.

#### Gas Chromatographs Division

5650 Brittmoore Road

Houston, TX 77041 USA

T: 713.827.6380, F: 713.827.3865

Toll Free in US and Canada: 1.866.GC.CENTER

Email: gc.csc@EmersonProcess.com

www.raihome.com/gc



**EMERSON**  
Process Management