

Analog wiring diagrams

Introduction

Our XA series gas chromatographs are furnished with one isolated 24V power supply to service six analog outputs. See the drawings on page 2 for more information. If the customer desires it, they can furnish power to each analog output while maintaining isolation between channels. See the drawings on page 4 for more information. Our XA series gas chromatographs are also capable of furnishing power to two analog inputs. These inputs are set at the factory to accept current (4-20 mA) sources, but they can be configured to accept voltage (0-10 VDC) sources. See the wiring diagram on page 5 for more information.

Factory analog wiring and switch settings

Consult the following diagrams before wiring a device:

1. This drawing shows how to wire up to six devices to the analog outputs that are located on the back plane. It also shows how to wire up to two analog inputs.

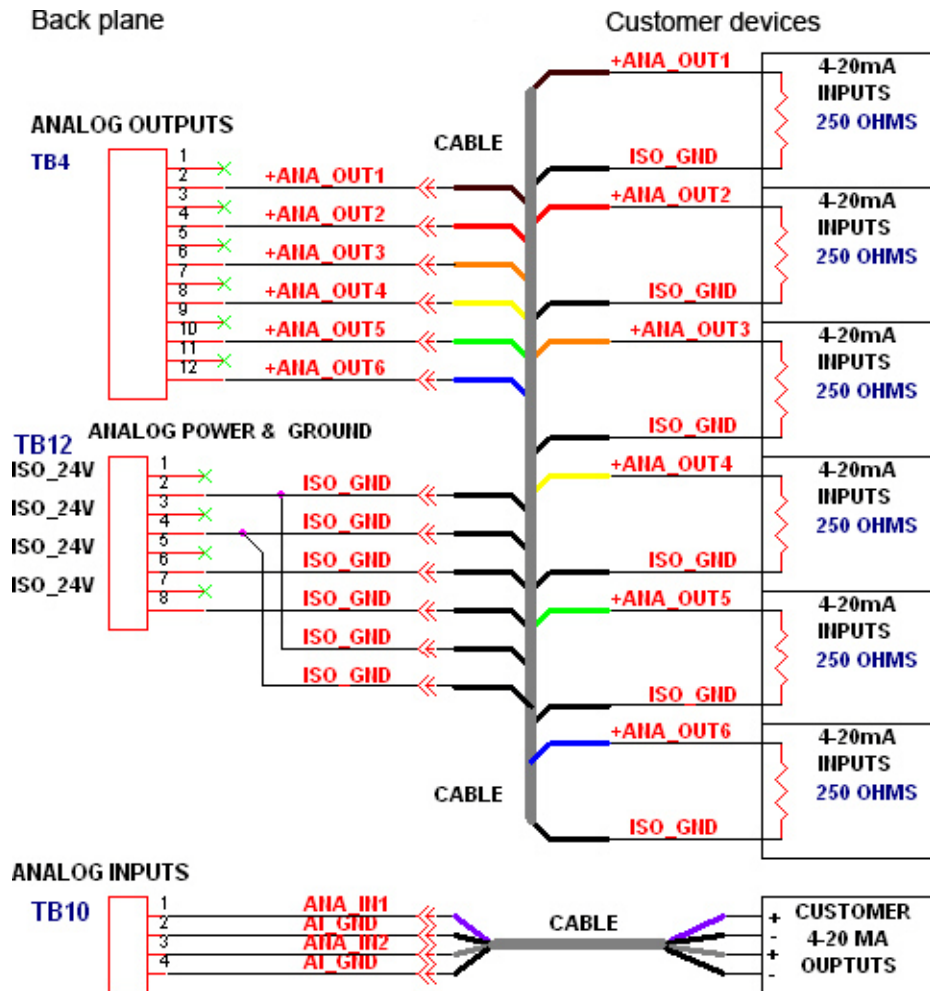

- This drawing shows the factory settings for the **analog output switches** that are located on the Base I/O board.

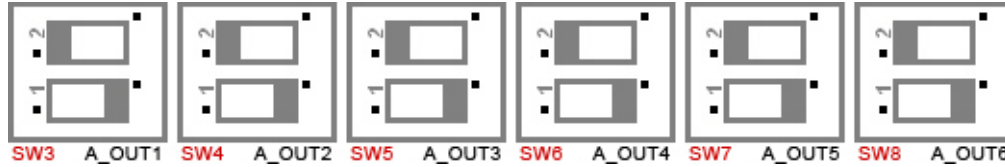

- This drawing shows the factory settings for the **analog input switches** that are located on the Base I/O board. These

analog inputs are set to accept a current (4-20 mA) source.

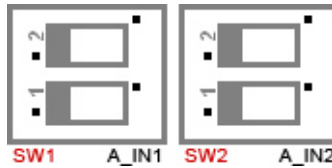

Note: To set an analog input to accept a voltage (0-10 VDC) source, flip the switch in the opposite direction, as shown below.

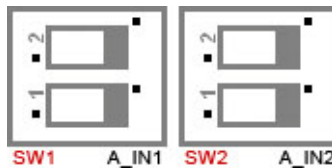

Wiring and switch settings for customer-powered analog outputs

Consult the following diagrams before wiring a customer-powered device:

1. This drawing shows the wiring that is necessary to provide power to each analog output while maintaining isolation between channels.

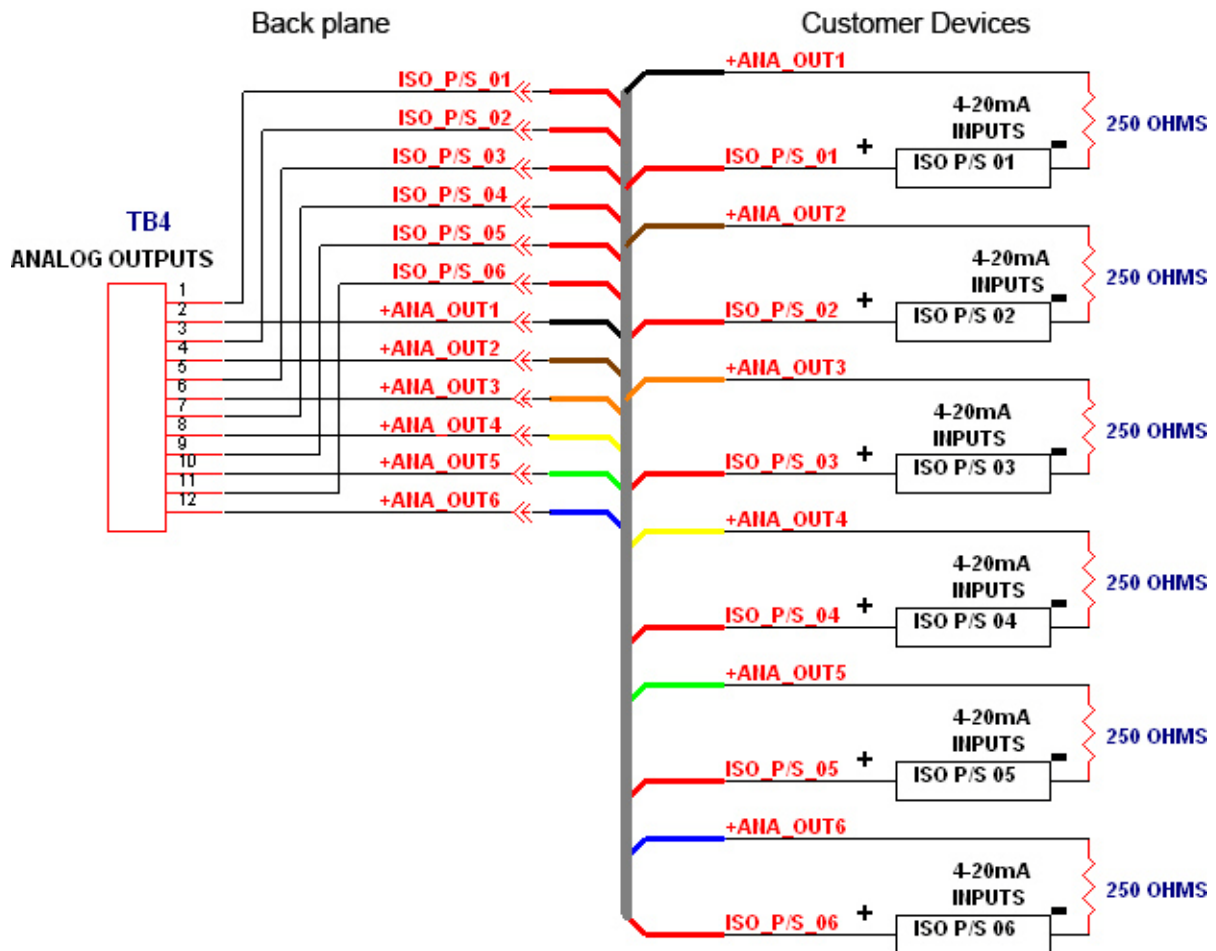

2. This drawing shows the settings for the **analog output switches**, located on the Base I/O board, that are necessary to

provide power to each analog output while maintaining isolation between channels.

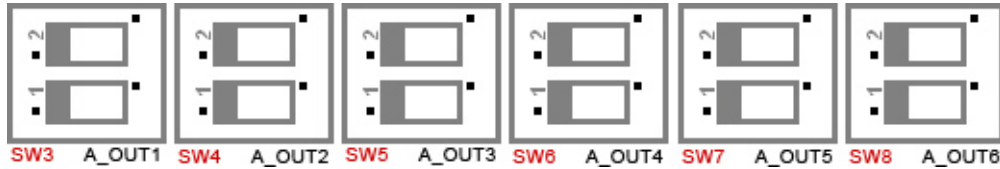

Typical wiring for line-powered transmitters

two 4-20 mA transmitters, such as pressure sensor transmitters.

The following drawing shows the most common wiring plan for supplying power to

