

# Improving refinery fluid catalytic cracking unit performance with process gas chromatographs

Process gas chromatographs have been used since the 1950s to provide real-time compositional data to process control systems. Today, there are tens of thousands of process gas chromatographs in use throughout the process industry making the gas chromatograph the analytical workhorse for on-line compositional measurements. One example of how process gas chromatographs are used for improving process operations can be found in the fluid catalytic cracking unit in a refinery.

In a refinery, one of the most important processes for converting heavy oils into more valuable gasoline and lighter products is the Fluid Catalytic Cracking (FCC) unit. Over 50% of the refinery's heavy petroleum goes through the FCC unit for processing. The FCC unit is also an important source of butene and pentene olefins used in refinery processes such as the alkylation unit. As a critical unit in the refinery, the alkylation unit's optimum operation is essential.

## The fluid catalytic cracking unit

The feed to the fluid catalytic cracking unit in a refinery is the heavy gas oils from the crude unit as well as vacuum gas oils from the vacuum crude unit. The feed can also come from other units that generate heavy petroleum streams such as the coker or deasphalter.

The feed stream is heated to more than 600°F and then mixed with freshly regenerated catalyst before it enters the main FCC reactor. The chemical reactions begin occurring immediately upon contact with the oil in the pipe leading to the reactor. During the "cracking" of the large molecules in the oil into smaller molecules, carbon forms on the surface of the catalyst and quickly de-activates the catalyst.

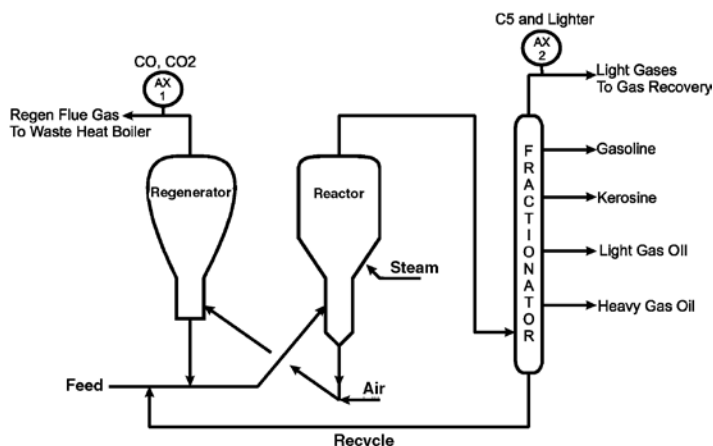

**Figure 1 - Flow Diagram of a Typical Fluid Catalytic Cracking Unit**

Once inside the reactor, steam is injected to strip off any oil clinging to the catalyst causing the catalyst in the reactor to move in a manner similar to being a "fluid"; hence the name fluid catalytic cracking. The cracked oil vapors flow out the top of the reactor with the spent catalyst flowing out the bottom.

As the catalyst leaves the bottom of the reactor, it is mixed with air and enters the regenerator vessel where the carbon on the surface of the catalyst is burned off. The regenerated catalyst leaves the bottom of the regenerator to be mixed with the feed, completing the catalyst flow path. Exiting the top of the regenerator is a very hot flue gas stream that is used to heat other boilers in the plant.

While the catalyst is being regenerated, the hot petroleum vapors leaving the top of the reactor enter the main fractionator. This fractionator acts like a miniature crude tower by separating the "cracked" petroleum stream into various

petroleum cuts such as gasoline, gas oils, etc. The heaviest fraction leaving the bottom of the main fractionator is typically recycled back to the feed stream for reprocessing. Exiting the overhead of the main fractionator is a gas vapor stream rich in olefin compounds. This stream is often sent to the vapor recovery unit where the olefins are recovered for use in processes like the alkylation unit.

**Improving fluid catalytic cracking unit performance with process gas chromatographs**

Several opportunities exist for process gas chromatographs to improve the fluid catalytic cracking unit's performance. The first process gas chromatograph (AX #1 in Figure 1) monitors the CO to CO<sub>2</sub> ratio in the flue gas leaving the top of the regenerator. This ratio is critical to regulating the temperature in the regenerator since high temperatures would damage the catalyst.

The second gas chromatograph (AX #2 in Figure 1) monitors the overhead vapors of the main fractionator. This gas chromatograph is typically used for two purposes. The first is to minimize the loss of naphtha/gasoline components in the overhead stream by keeping the C<sub>5</sub> concentration low. The second purpose is to monitor the C<sub>4</sub> and C<sub>5</sub> olefins generated in the reactor. These olefins are important feed components to other processes in the refinery such as the alkylation unit. A summary of these applications can be seen in Figure 2.

**The Emerson solution**

Emerson has a long history of providing process gas chromatographs to the refining industry. Emerson's process gas chromatographs have set the standard for on-line process measurement by supplying analyzers that are both robust and capable of handling the analytical requirements.

Analyzer #	Stream	Components Measured	Measurement Objective
1	Regenerator flue gas	CO, CO <sub>2</sub>	Used to calculate CO/CO <sub>2</sub> ratio to determine catalyst regeneration efficiency
2	Main fractionator overhead	H <sub>2</sub> – C <sub>5</sub>	Minimize loss of C <sub>5</sub> + components as well as monitor C <sub>4</sub> – C <sub>5</sub> olefins production

**Figure 2 - Summary of Process Gas Chromatograph Applications in a Typical Refinery Fluid Catalytic Cracking Unit**

*The contents of this publication are presented for informational purposes only, and while every effort has been made to ensure their accuracy, they are not to be construed as warranties or guarantees, express or implied, regarding the products or services described herein or their use or applicability. All sales are governed by our terms and conditions, which are available on request. We reserve the right to modify or improve the designs or specifications of our products at any time without notice.*



For more information:  
[www.EmersonProcess.com](http://www.EmersonProcess.com)

