

# Critical Data Backup Application

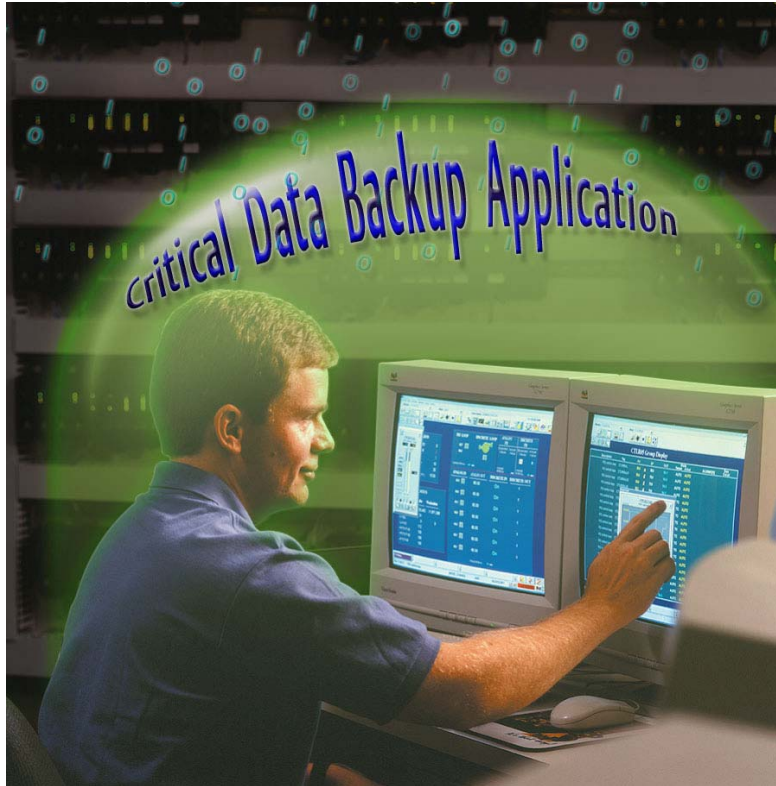

*Protect your investment in configuration and critical process data with Emerson's fail-safe solution – Critical Data Backup Application.*

- Improve process availability
- Reduce operations and maintenance costs
- Enable regulatory compliance

## Introduction

Unlike control system hardware that is generally replaceable, your unique configuration and critical data are not. These assets can contain years of work, experience, plant operations information, and process records. Because the cost of data loss due to operator errors, accidental deletion, system or component failures, viruses and other threats is staggering, data protection, recovery and security are major concerns.

You can protect your process control investment with the Critical Data Backup Application (CDBA) from the Process Solutions business of Emerson Process Management. This application delivers a reliable method for automatically backing up data, improving data availability and security, minimizing data recovery costs, and providing business continuity.

Concerned about government regulations? Take advantage of Emerson's knowledge and experience in validation and other regulatory requirements. The Critical Data Backup Application will provide you with a method to meet 21 CFR Part 11 compliance for backup, recovery, and preservation of electronic records. The application also includes sample documentation templates to assist with validating your Critical Data Backup Application to the FDA or other government regulatory compliance agencies.



## CUSTOMER BENEFITS



**Improve  
Process  
Availability**

- *Provides structured environment for fast and efficient data recovery.*
- *Minimum risk of human error.*
- *DeltaV and other process control data can be protected.*
- *Customized, plant specific application.*



**Reduce  
Operations &  
Maintenance  
Costs**

- *Replaces labor intensive manual backup with an automatic process.*
- *Reduces rework due to backup errors.*
- *Reduces cost of backup procedures plant wide.*
- *Flexible scheduling avoids data access conflicts with plant operations.*



**Enable  
Regulatory  
Compliance**

- *Provides a backup record of product genealogy.*
- *Developed to facilitate regulatory compliance.*
- *Fully validated solution executed by subject matter experts.*

### Application Scope

The Critical Data Backup Application consists of a number of components that provide a complete solution for your data backup needs. There are options, however, to allow customization of the application to fit any need and application. The main components of the application are: [Licenses](#) (Software), [Hardware](#) (for data collection and storage), [Implementation Services](#), and Annual [Application Support](#). In addition, a Standard Plan is provided for complete backup services while the optional [Regulatory Compliant Plan](#) provides additional services critical to any application requiring regulatory compliance of any kind. The table on the next page details the typical scope of supply for the Standard and Regulatory Compliant Plans.



With Critical Data Backup Application you get:

		Standard Plan	Regulatory Compliant Plan	
<b>Software Licenses</b> (based on the number of backup nodes)	<ul style="list-style-type: none"> <li>■ Standard software, licenses &amp; documentation</li> <li>■ Validation documentation                             <ul style="list-style-type: none"> <li>○ Functional Design Specification</li> <li>○ Site Acceptance Test Protocol</li> <li>○ Standard Operating Procedures</li> </ul> </li> </ul>	✓	✓ ✓	
	<ul style="list-style-type: none"> <li>■ Backup Server or workstation hardware</li> </ul>	✓	✓	
	<b>Implementation Services</b> (Subject to Pre-Sale Qualifications)	<ul style="list-style-type: none"> <li>■ Software installation &amp; configuration</li> <li>■ Site training in configuration, administration &amp; data restoration</li> </ul>	✓ ✓	✓ ✓
		<ul style="list-style-type: none"> <li>■ User Requirement Specifications</li> <li>■ Dataflow Schema</li> <li>■ Network Architecture Schema</li> <li>■ Test Protocol</li> <li>■ Installation Qualification Protocol</li> <li>■ Operation Qualification Protocol</li> <li>■ Client Acceptance Test Plan and Procedure</li> <li>■ Management of validation plan execution and compliance with validation requirements</li> </ul>		✓ ✓ ✓ ✓ ✓ ✓ ✓ ✓
		<ul style="list-style-type: none"> <li>■ Initial 1-year Application Support subscription</li> </ul>	✓	✓

The Critical Data Backup Application Delivery Process is performed in phases:

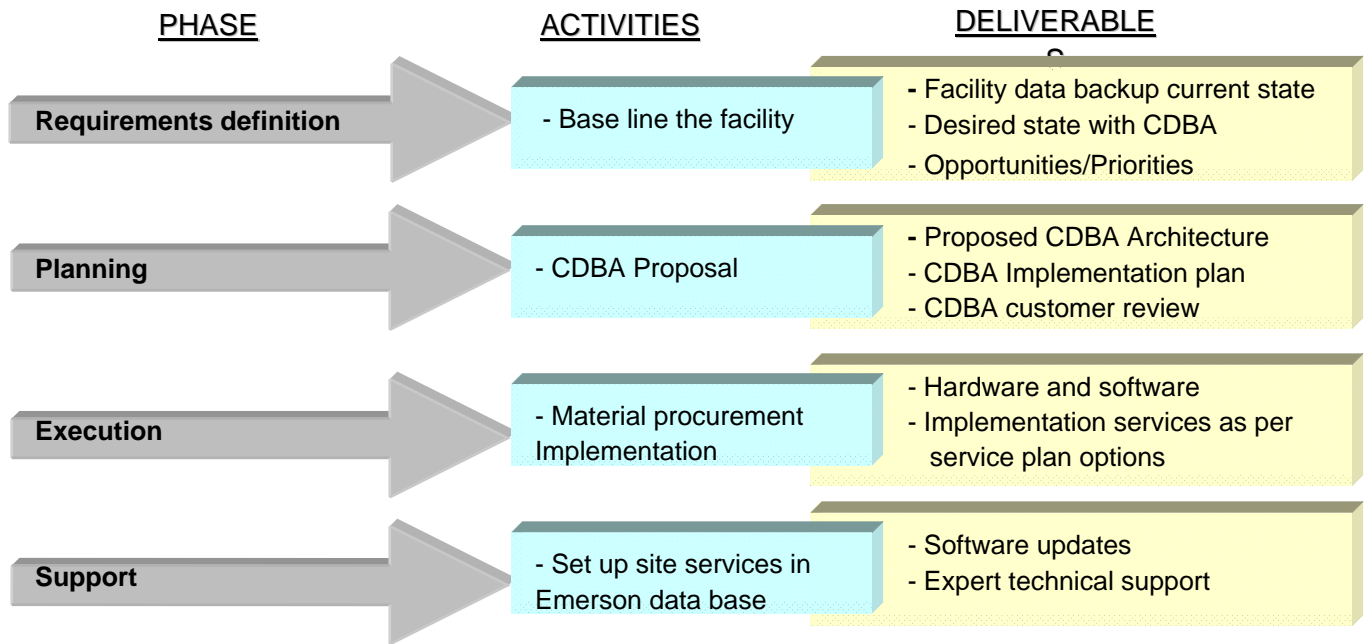

## Application Technical Details

The Critical Data Backup Application can work within both local and LAN-based network structures. The backup workstation or server may reside on either the business network or a dedicated backup network.

The Critical Data Backup Application can manage the backup of one or more DeltaV systems, third-party data sources located on DeltaV workstations, and third-party data sources on non-DeltaV workstations. The application will support backups of the following key data sources:

- DeltaV database export to .FHX format (Formatted Text)
- DeltaV Objectivity database dump (Objectivity)
- DeltaV Version Control Audit Trail database (SQL Server DB)
- DeltaV IFIX graphics files
- DeltaV Event Journal
- DeltaV Batch Event EVT directory Tree
- DeltaV Powerup Directory
- DeltaV YellowPages Directory
- DeltaV Import/Export Directory Tree
- DeltaV OPC Mirror
- DeltaV Binary Directory
- DeltaV Process History View chart and trend definition files
- DeltaV Batch Historian (SQL Server DB)
- DeltaV Continuous Historian (Archive files)
- DeltaV Continuous Historian database configuration files
- Excel spreadsheets files including those used with PI Datalink

- PI ProcessBook trend and display files
- AMS SQLServer database dump file
- Web files (.HTML, .ASP, etc.) and related files. A backup of all DeltaV related web files.
- Windows Repair Directory
- Other non-DeltaV databases/files (PI, SQL, flat files, other)

Configuration for the Critical Data Backup Application is administrated from the backup server. This minimizes the amount of configuration required at the individual workstations to be backed up. The configuration at the backup server user interface consists of: adding a node, selecting the type of data being backed up, and browsing to the proper source and destination directory paths.

Once the application is configured, a series of backup agents transfer information from each selected DeltaV and non-DeltaV workstation being backed up to the central backup server. The information will then be copied to the designated long term storage media. Logs are generated identifying all information being copied to the long-term storage media. Any errors or warning messages are included in the log and noted in a report to the primary backup operator.

Data recovery is a manual exercise. The application documentation provides simple step by step instructions for recovering all or part of backed-up data files from storage media.

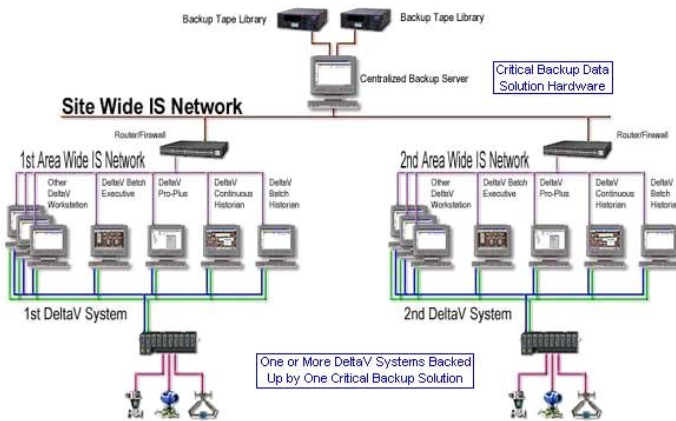

Typical Application Hardware Installation

**Key Features**

Some of the key features of Critical Data Backup Application include:

- Protects all files required to recover and restore an automation control system.
- One application can protect multiple DeltaV systems.
- Backups of all critical data are automatically generated and copied to storage media.
- Backup frequency can be configured for each file and/or database independently as needed.

- Administrators can be notified by email of backup completion status.
- Selective recovery of back-up files, databases, and Windows repair files.
- Step-by-step instructions provided for recovering all or any part of backed up files.
- Meets regulatory requirements for long-term storage of operations historical information, system applications, data, logs, audit trails and other data.

**Pre-Sale Qualification**

The Critical Data Backup Application is available only for DeltaV systems with version 8.X or later software. A written summary of the project objectives and expected timing must be received and reviewed by Emerson Process Management, Process Solutions prior to order acceptance. This is a safeguard for the customer to ensure the necessary skills are available from Emerson Process Management within the expected timing and to provide a commentary on the scope of consultation available along with a budgetary estimate of required hours.

Any orders received without this Pre-Sale Qualification will be considered for general-purpose application and configuration consultation. In most situations, Emerson Process Management will respond to requests for general-purpose consultation within one business day.

**Ordering Information—Licensing**

Description	How To Order:
Licensing is dependent upon the number of backup nodes required. Licenses are available in increments of 5 nodes for Standard and Regulatory Compliant Applications. For applications requiring more than 15 nodes, a 10-node scale-up license is also available.	Please Contact Your Local Emerson Sales Office

**Ordering Information—Hardware**

Description	How To Order:
Standard hardware is not provided in this data sheet due to the various options that are available.	Please Contact Your Local Emerson Sales Office

**Ordering Information—Implementation Service Plans & SureService™ Support Plans**

Description	How To Order:
<p>Standard or Regulatory Compliant Implementation Plan (Subject to Pre-Sale Qualification).</p> <p>1-Year SureService Application Support Plan (initial 1-year subscription is included in purchase price of application)</p> <p><b>NOTE:</b> SureService Application Support for CDBA includes:</p> <ol style="list-style-type: none"> <li>1. One year technical phone support. A technical support staff will be available to resolve technical issues Monday through Friday from 8 AM to 5 PM CST. Customers should contact their local Emerson representative to open support calls.</li> <li>2. Critical Data Backup Application Software updates during the annual application support period.</li> <li>3. Annual application support is for a one-year subscription period and will become renewable every year thereafter.</li> <li>4. DeltaV Guardian support is a prerequisite for ongoing operational support of this application.</li> </ol>	Please Contact Your Local Emerson Sales Office

To learn how comprehensive SureService™ solutions address your process management needs, contact your local Emerson sales office or representative today or visit our web page at <http://www.SureService.com/>.

**To locate a sales office near you, visit our website at:**  
[www.EmersonProcess.com/DeltaV](http://www.EmersonProcess.com/DeltaV)

**Or call us at:**  
 Asia Pacific: 65.777.8211  
 Europe, Middle East: 41.41.768.6111  
 North America, Latin America: +1 800.833.8314 or  
 +1 512.832.3774

**For large power, water, and wastewater applications contact Power and Water Solutions at:**  
[www.EmersonProcess-powerwater.com](http://www.EmersonProcess-powerwater.com)

**Or call us at:**  
 Asia Pacific: 65.777.8211  
 Europe, Middle East, Africa: 48.22.630.2443  
 North America, Latin America: +1 412.963.4000

© Emerson Process Management 2011. All rights reserved. For Emerson Process Management trademarks and service marks, go to: <http://www.emersonprocess.com/home/news/resources/marks.pdf>.

The contents of this publication are presented for informational purposes only, and while every effort has been made to ensure their accuracy, they are not to be construed as warranties or guarantees, express or implied, regarding the products or services described herein or their use or applicability. All sales are governed by our terms and conditions, which are available on request. We reserve the right to modify or improve the design or specification of such products at any time without notice.

