

Emerson Migration Solutions for Moore® Systems

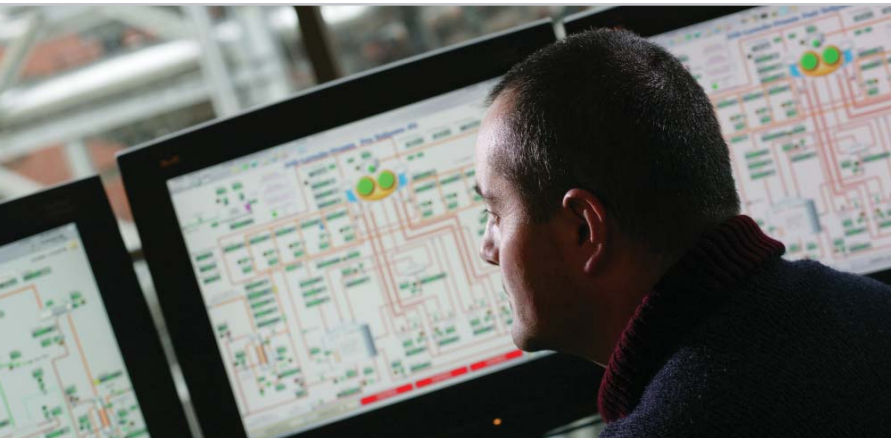

*Get on the
path to a smart
digital plant*

Your legacy APACS® or QUADLOG® systems have done their job over the years. But with today's increasing market pressures, the demand is for ever higher performance from your process. System upkeep is increasingly resource intensive. Valuable personnel frequently must address tag server and engineering software maintenance. Third-party resellers are often the only source for obsolete parts to keep the system running. Vendor support has been declining over recent years, particularly for HMI and batch products. With a legacy system draining your resources, how can you compete?

How much profit is lost by delaying upgrades to the technologies that run your process?

Emerson is redefining traditional systems migration, offering phased transition to the DeltaV™ system and services tailored to help you justify investments in a smart digital plant. Industry-leading migration solutions are available - some you can implement right away with no downtime.

Emerson's solutions for Moore APACS and QUADLOG systems provide flexibility regarding which legacy components to keep and which to replace – and when. And implementation is a breeze, using standard DeltaV system configuration methods.

Emerson offers tremendous expertise in all aspects of modernization projects. Audits help evaluate your baseline and allow our experts to draft an initial modernization plan that uncovers the best opportunities for improving your site's performance.

Introduce technologies that will boost your competitive edge now and for years to come. Digital busses, embedded advanced control, self-diagnosing instrumentation, on-the-fly scalability, wireless solutions plug-and-play business integration, and industry-leading batch capabilities can lower engineering, installation, and startup costs, while producing ongoing operations and maintenance savings.

“With the DeltaV system, all phases of our project-engineering, installation, commissioning, training and our operating process exceeded our expectations.”

–R. Sivakumar,
Tanfac Industries, India.

Share two systems' data at one Operator Station

Product solutions

Traditional connection methods like serial interfaces can provide connectivity between Moore and DeltaV systems. Emerson offers these and more.

The DeltaV Connect™ Solution for Moore® Systems, shown here, seamlessly puts DeltaV Operator Stations to work with your Moore controllers and I/O; installs and starts up with NO downtime, eliminates tag servers, and requires little or no Moore system configuration.

Conversion services based on purpose-built tools complete the DeltaV Connect offering, to generate the DeltaV database and graphics from your Moore system database and display files. This greatly reduces implementation time and eases operator re-training. Or, Emerson can expertly design and deliver entirely new DeltaV displays to enhance your process view.

DeltaV Connect™ Solution for Moore® Systems Redundant IEM Architecture

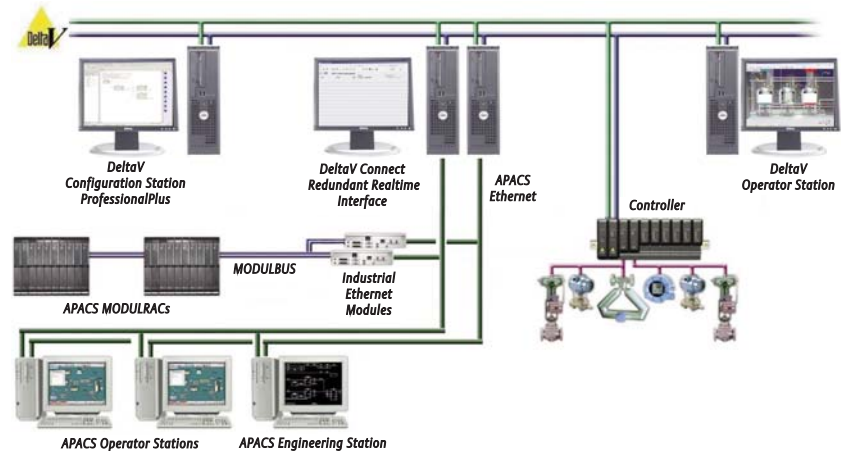

With the DeltaV Connect solution installed, you can - at any time - configure new DeltaV controller and I/O, for plant expansions or controller migrations.

Save panels and wiring

When moving controller and I/O into the DeltaV system, consider FlexConnect® solutions, which physically link DeltaV I/O to existing Moore field wiring terminations.

FlexConnect solution benefits

- Saves existing wiring investment
- Speeds startup by not disturbing field connections
- Reduces rewire-related process downtime by 75% or more
- Preserves HART® signals; makes HART data available in the DeltaV system.

For more product solution detail, see the white paper: www.EasyDeltaV.com/pd/WP_APACStoDeltaV.pdf

Learn more about FlexConnect at www.EasyDeltaV.com/Solutions/FlexConnect

Learn more about this solution and these services at www.EasyDeltaV.com/Solutions/DCS

Contacts:

To locate a sales office near you, visit www.emersonprocess.com/systems/reach/index.html

To learn more about Emerson migration capabilities, visit www.emersonprocess.com/solutions/migration



If you found this brochure valuable, we also recommend the following brochure:

- **Automation System Modernization** for your migration, project planning, design, and implementation needs.

© Emerson Process Management 1996—2008. All rights reserved. For Emerson Process Management trademarks and service marks, go to www.emersonprocess.com/home/news/resources/marks.pdf

DeltaV Connect Solution for Moore Systems is not a product approved or endorsed by Siemens Energy Automation. Siemens Energy Automation claims to own the following marks: Moore, APACS, QUADLOG. All other marks are the property of their respective owners.

The contents of this publication are presented for informational purposes only, and while every effort has been made to ensure their accuracy, they are not to be construed as warranties or guarantees, express or implied, regarding the products or services described herein or their use or applicability. All sales are governed by our terms and conditions, which are available on request. We reserve the right to modify or improve the design or specification of such products at any time without notice.