

## Operating Instructions

IP4002, Rev. AB

April 2008

**Level**

---

# CLS Series

RF Capacitance level probe



**mobrey**

[www.mobrey.com](http://www.mobrey.com)

  
**EMERSON**<sup>™</sup>  
Process Management

# 1. Introduction

The CLS is a **fixed point Level Controller** incorporating a microcomputer that is used to automatically calibrate the **probe** to suit the material being detected. Full manual override facilities are included. The unit has full ATEX approval for use in dust hazard installations, such as flourmills, sawmills or any application where dust may be present.

The CLS employs a **power shield** to minimise the effect of material adhering to the probe, making it ideal for detecting most materials including sticky or viscous types. It is equally suited to both liquids and solids. The probe may be a solid rod, metal plate or wire rope.

The self-contained CLS is normally supplied with a probe, available as a stainless steel rod in standard lengths of 100mm, 200mm, 1 metre or as a 10 metre wire rope suspension probe and weight. The probe must be screwed into the CLS. Prior to attachment, the probe length can be reduced or increased, if desired, but see notes (a) and (b) regarding minimum surface area.

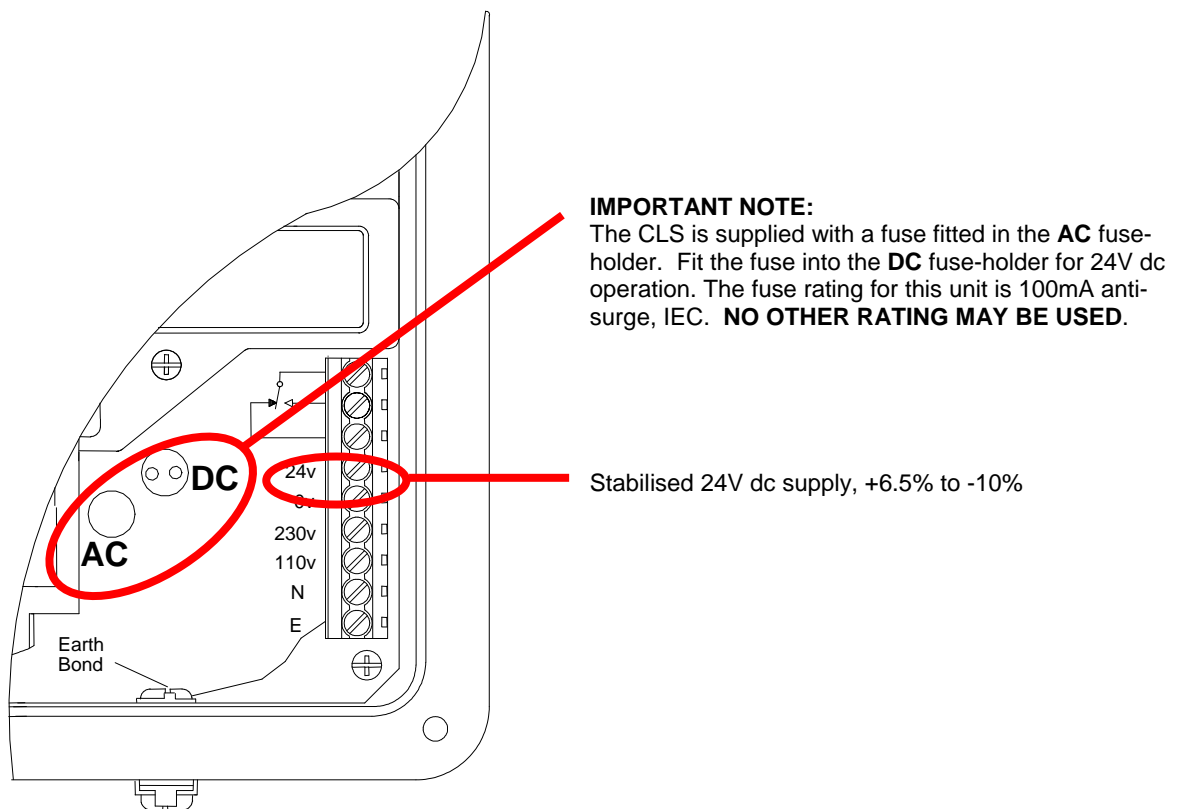

### IMPORTANT NOTE:

The CLS is supplied with a fuse fitted in the **AC** fuse-holder. Fit the fuse into the **DC** fuse-holder for 24V dc operation. The fuse rating for this unit is 100mA anti-surge, IEC. **NO OTHER RATING MAY BE USED.**

Stabilised 24V dc supply, +6.5% to -10%

Figure 1

### NOTES:

- (a) The CLS sensitivity is proportional to the surface area of the probe. When using a 16mm diameter probe, the minimum probe length to use for most materials is 200mm.

If the probe length needs to be reduced to less than 200mm, the surface area should be maintained. This can be achieved by increasing the diameter by fitting a metal tube over the probe or by bending the probe rod. In certain high-density materials, it may be possible to reduce the length without compensation.

- (b) Mobrey Measurement offers a free product test service. To use this service, supply **2 litres** of product in a **sealed** container (to prevent ingress or loss of moisture). The product will be tested and its suitability confirmed. You should also notify us of any safety precautions which should be observed during testing. (Supply suitable COSHH datasheet).

## 2. Installation

A **thread-locking compound** is already applied to the **probe-fixing stud** of the CLS. This will prevent the probe rod from vibrating loose. Once fitted, the compound is fully hardened after 20 minutes.

CLS will operate on **110V/230V ac 50/60Hz** or **24V dc** supplies (see important note about fuse in Figure 1). The unit may be wired to a supply using ordinary, non-screened cable of any length and need not be separated from other cables.

Note : The 0V supply terminal is bonded to Earth terminal (E).

### A SUPPLY EARTH IS ESSENTIAL!

When mounting the CLS, care must be taken to ensure that the exposed end of the **power shield** protrudes into the container. See Figure 3. Mount unit securely to minimise vibration.

Connect in accordance with Figure 1 and set the **high/low switch** to the required position (see Figure 5). Ensure that the cable gland and back cover are fully tightened when finished. The CLS has two 20mm cable entries, one of which is blank, the blank may be drilled out carefully if required; it must not be knocked out. All cable glands must be ATEX approved, IP65 rated. The unit should be wired and earthed in accordance with appropriate Electrical Regulations. The unit must be earthed and the terminal **MUST** be bonded to the earth bond stud.

On metal containers, unit earth **MUST** be bonded to the container. If the container is non-metallic, metal flanges or couplings used to mount probe should be bonded to earth. This also applies to probes mounted in wooden or plastic tops of metal bins.

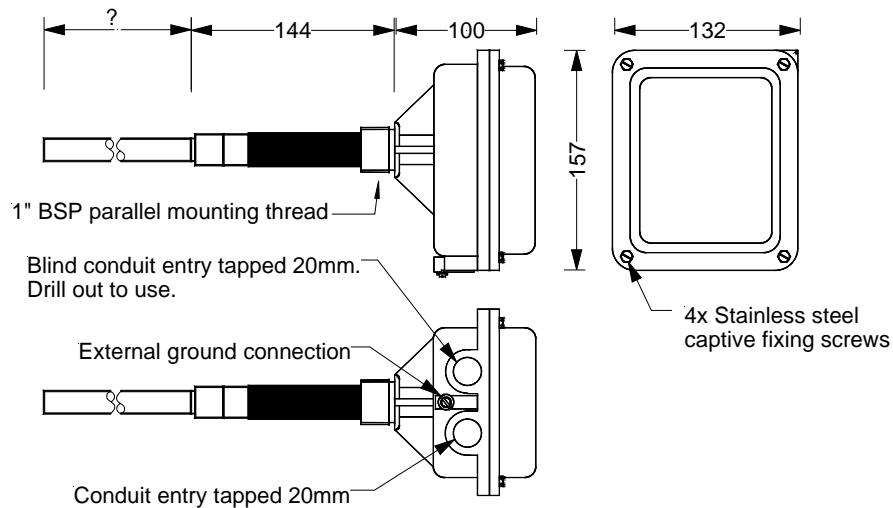

Figure 2: fig5

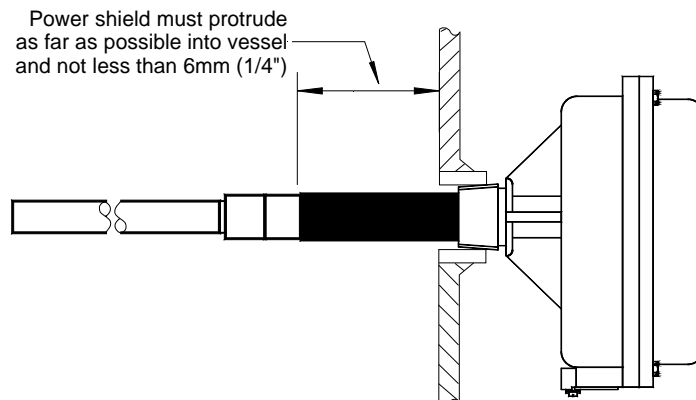

Figure 3: fig6



## 4. Commissioning

The CLS can be calibrated automatically, manually or by a combination of the two methods. Usually, automatic calibration is the simplest method, particularly when the vessel can be filled to cover the probe.

Manual calibration is useful when a number of probes in similar applications need to be set. Once the correct calibration has been determined and noted, on one system, the remainder can be set to the same setting.

### 4.1 Display Functions

The display shows a number of different values depending upon whether the unit is in manual or auto mode and cal or park mode.

### 4.2 Park Mode

In normal operation, the display shows a value representing the capacitance measured by the probe at the time.

Pressing the **UNCOVERED/LOWERED** button will cause the display to show **uxxx** followed by **rxxx**. Pressing the **COVERED/RAISED** button will cause the display to show **cxxx** followed by **rxxx**.

The **cxxx** is the probe covered value measured during calibration, **uxxx** is the uncovered value and **rxxx** is the relay operating point that the CLS calculates and is half way between the two measured values.

**Note: The settings are "view only" in park mode, they cannot be altered.**

### 4.3 Cal Mode - auto/man switch set to auto

In this mode, pressing the **UNCOVERED/LOWERED** button will cause the unit to measure and display the uncovered value and recalibrate the relay operating point if necessary. Pressing the **COVERED/RAISED** button (with the probe covered) will cause the unit to measure and display the covered value, again re-calibrating the relay operating point if necessary.

### 4.4 Cal Mode - auto/man switch set to man

In this mode, pressing the **COVERED/RAISED** button will cause the display to momentarily display the present relay operating point and then to increment the setting slowly and then rapidly to set a higher operating point. Pressing the button will cause the display to momentarily show the current relay operating point, and then decrement the setting, slowly and then rapidly.

Once adjusted in manual mode, any previous settings will be lost. The **cxxx** reading will be 1 above the relay operating point and the **uxxx** reading 1 below.

**Note: Always return to "Park" (after calibration)**

### 4.5 Automatic Calibration - material available

#### Procedure:

- (1) Set Park/Cal switch to "Cal" and Auto/Man switch to "Auto". The Cal LED will flash.
- (2) Ensure that the probe is uncovered. Then press and hold the **UNCOVERED/LOWERED** button. The display will show **uxxx** followed by **rxxx**.
- (3) Fill the vessel sufficiently to cover the probe and then press the **COVERED/RAISED** button. The display will show **cxxx** followed by **rxxx**.
- (4) Return the Park/Cal switch to "Park". The unit is now calibrated – **uxxx** and **cxxx** values can be viewed but not altered by pressing the **UNCOVERED/LOWERED** and **COVERED/RAISED** buttons.

### 4.6 Semi-automatic Calibration - material not available

#### Procedure:

- (5) Follow steps 1 and 2 above.
- (6) Set the Cal/Park switch to "Park" and then press the **UNCOVERED/LOWERED** button. Note the **uxxx** reading but ignore the **rxxx** reading. Return the Cal/Park switch to "Cal" and set the Auto/Man switch to "Man".
- (7) From Table 1 below, select the nearest material to the type to be detected, then add the **Increment** value to the **uxxx** reading determined in step 6.
- (8) Press the **COVERED/RAISED** button to raise the reading and the **UNCOVERED/LOWERED** button to lower the reading to achieve the calculated setting (**uxxx + Increment**).

- (9) Return the Cal/Park switch to “Park”. Then, press the **UNCOVERED/LOWERED** and **COVERED/RAISED** buttons to confirm that the relay operating point **rxxx** is set correctly. The **uxxx** and **cxxx** settings will be one below and one above the reading.

**Table 1: Table of Typical Settings**

Material Type	Increment
Light	+15
Medium	+30
Heavy	+60 or greater

#### 4.7 Time Delay

The CLS has an **adjustable delay** from zero to 128 seconds, the timer operating on both material arriving and leaving. To set the time delay, proceed as follows.

- (10) Set the Cal/Park switch to “Cal”.
- (11) Press and hold the **TIMER** button. The display will show **t000** which increments from zero, adding one second each time the button is pressed. Release the button when the required delay time is shown.
- (12) Return the Cal/Park switch to “Park” and press the **TIMER** button to confirm the timer setting.
- (13) The timer can be altered to a longer or shorter delay by repeating the procedure from step **10** onwards.

## 5. CLS Specification

<b>Type / Certificate No:</b>	<b>Baseefa04ATEX0202</b>
<b>Approval:</b>	Ex II1D T100°C Tamb -20°C to +50°C IP65
<b>Protection:</b>	IP65.
<b>Enclosure:</b>	Modified Polyamide 66.
<b>Mounting:</b>	Via 1" BSP Parallel thread.
<b>Voltage:</b>	110V/230V ac 50/60 Hz or 24V dc (Stabilised) (+6.5% to -10%).
<b>Rating:</b>	2.5VA.
<b>Operating Temperature:</b>	-20 to +50°C. (ATEX certification) -20 to +70° (only when ATEX certification is not required)
<b>Output:</b>	S.P.C.O contacts rated at 2.5A 240V non-inductive.
<b>Timer Delay:</b>	0 - 128 second variable (prevents false signalling from splashing). Set via pushbutton.
<b>Earth Bonding:</b>	Earth stud located on exterior of main case. This stud must be connected to earth, bonded to container or metalwork of container and, if used, connected to exterior of armour cabling.
<b>Probe Length:</b>	100mm, 200mm, 1 metre or 10 metre wire rope.

## 6. Guarantee

The equipment is covered by a 12 months guarantee from the date of shipment. Any faults arising due to faulty materials or workmanship, within the guarantee period, will be corrected free of charge providing the equipment is returned to us carriage paid.

## 7. Certificate of Conformity

The equipment covered by these instructions has been manufactured and tested in accordance with our quality assurance procedures and conforms fully to our published specifications.

## **8. Health and Safety**

If the equipment covered by these instructions is installed and operated as directed, it presents no hazard and conforms fully to health and safety regulations.

Reference should be made to safety instructions IP4002/SI when installed in explosive atmospheres.

# Level

---

*The Emerson logo is a trade mark and service mark of Emerson Electric Co.*

*Rosemount is a registered trademark of Rosemount Inc.*

*Mobrey is a registered trademark of Mobrey Ltd.*

*All other marks are the property of their respective owners.*

*We reserve the right to modify or improve the designs or specifications of product and services at any time without notice.*



*International:*

**Emerson Process Management**

**Mobrey Measurement**

158 Edinburgh Avenue, Slough,  
Berks, SL1 4UE, UK

Tel: +44 (0)1753 756600

Fax: +44 (0)1753 823589

[www.mobrey.com](http://www.mobrey.com)

*Americas:*

**Emerson Process Management**

**Rosemount Inc**

8200 Market Boulevard  
Chanhassen, MN USA 55317

Tel: (US) (800) 999-9307

Tel: (International) (952) 906-8888

Fax: (952) 949-7001

[www.rosemount.com](http://www.rosemount.com)

