

Mobrey

MCU900 Series Industrial transmitter control unit

Software Version 2.01



MCU900 is the generic name used in this manual for the MCU900 range of control units comprising :-

MCU901
MCU902
MCULOG
MCU90F



LISTED
PROCESS
CONTROL EQUIPMENT
PROCESS
CONTROL EQUIPMENT
ASSOCIATED APPARATUS

Safety Precautions

The following safety precautions should be observed before using this product or working on the attached cables.

This MCU900 product is intended for use by qualified personnel who recognise shock hazards and are familiar with the safety precautions required to avoid possible injury. Read the operating information carefully before using the product.

The types of product users are:

Responsible body: This is the individual or group responsible for the use and maintenance of equipment, and for ensuring that operators are adequately trained.

Operators use the product for its intended function. They do not require access to the electrical connections within the control box, and would normally only operate the external keypad and monitor the display.

Maintenance personnel perform routine procedures on the product to keep it operating, for example, checking the line voltage or checking electrical connections, replacing mains fuses etc.

Service personnel are trained to work on live circuits, and perform safe installations and repairs of products. Only properly trained service personnel may perform installation and service procedures. However, the only serviceable part in MCU900 is the mains cartridge fuse.

Users of this product must be protected from electric shock at all times. Product users must be trained to protect themselves from the risk of electric shock.

Periodically inspect the connecting cables for possible wear, cracks, or breaks.

The fuse must only be replaced with same type and rating for continued protection against fire hazard.

To clean the instrument, use a damp cloth with a mild, water based cleaner. Clean the exterior of the instrument only. Do not allow liquids to enter or spill on the instrument.

WARNING - If this equipment is used in a manner not specified by Mobrey Measurement, the protection provided may be impaired. The MCU900 is regarded as permanently installed equipment and as such a double pole switch or circuit breaker must be included in the installation. This should be in close proximity to and not obstructed by the equipment. This must be marked as its disconnecting device.

Disconnect supply before removing terminal cover.

The IP/NEMA rating is only achieved when unit is correctly assembled with supplied parts and suitable cables. Customer supplied glands must be suitable for application.

Under no circumstances must voltages higher than those stated in this manual be applied.

The installation of the MCU900 and its associated power cables must be such that tank overflow, local flooding or pump failure do not cause these to be submerged or subject to flows of water. Sensors and sensor cabling can be submerged without hazard to equipment operators when correctly connected as described in this manual.

Explanation of symbols:  = Refer to manual

The I.S. earth terminal, marked  must be connected to an external Intrinsically safe earth for all hazardous area systems.

CHECK THAT THE POWER SUPPLY IS SUITABLE BEFORE SWITCHING POWER ON.

Internal adjustments can select mains 230 Vac power, which makes the equipment unsuitable for 115V AC supplies. Check this Voltage selection switch is set to suit for the available power supply.

HAZARDOUS AREA SYSTEMS :-

Where the MCU900 is connected to a transmitter located in a hazardous area, additional instructions apply. Refer to page 6 and control drawing 71097/1121 on page 26.

The symbol  in the text of this manual refers the reader to page 6 and control drawing 71097/1121 as relevant.

CONTENTS

	Page
1. Product Introduction	4
1.1 Control Unit functions	4
2. Mobrey MCU900 Series Controller	5
2.1 Display and keypad	5
2.2 Type numbering system	6
2.3 Safety data	6
2.4 Electrical Specifications	7
3. MCU900 Control Unit Installation	8
3.1 Environmental specification	8
3.2 MCU900W Wall Mounting models	8
3.2.1. Electrical connections : MCU900W Wall mounting models	10
3.4. Notes on transmitter installation & cabling	11
3.4.1 Special notes for connecting HART transmitters	12
3.5. Power connection	13
3.6. Earthing	13
3.7. Relays	13
3.8. Current output	14
3.9. Digital control voltage free contact inputs	14
3.10. RS232	15
4. Maintenance / Inspection	15

Appendices

Appendix 1 Introduction to programming the MCU900	16
Appendix 2 Control drawing 71097/1121	26

Associated manuals

IP2040/QS_UL	Quickstart Manual covering use of the MCU900 with a Mobrey Measurement ultrasonic transmitter
IP2041/QS	Quickstart manual for Differential system
IP2030/OM	Detailed technical programming and operating manual
IP2042/QS	Quickstart manual for Logging system

Footnote :-

In this manual the following terms are used which refer to trademarks from other manufacturers:

HART: is the protocol adopted for the MCU900 SMART Communications.

HART is a registered trademark of the HART Communications Foundation and is a mnemonic for Highway Addressable Remote Transducer.

1.0 Product Introduction

MCU900 is the generic family name for a range of industrial transmitter control units, providing a wide range of control functions and a visual display of the measured variable. This tough IP65/NEMA 4x Wall mounted control unit is suitable for either indoor or outdoor installation. The controller will accept a 4-20mA signal from a self-powered transmitter or can provide 24V dc power to the transmitter if required.

A HART transmitter, powered from the MCU900, can be connected to the MCU900 and all Universal plus some Common Practice commands will be implemented.

The MCU900 may be connected to a 4-20mA transmitter installed in a hazardous area. However, the MCU900 is designed for mounting in a non-hazardous (safe) area.

Control functionality is provided by the 5 SPCO voltage free contact relays in the MCU900. There is also an isolated 4-20mA signal out.

For applications where the functionality of the MCU900 is linked to other external events, 2 digital input ports are provided to accept contact closure signals.

The MCU900 is simply programmed using the 6 key membrane keypad on the front of the unit accessed by opening the transparent quick release front cover. Menu structured programming is employed, with the display assisting the user with dynamic help text. See Appendix A.

1.1. Control Unit Functions

Using either a standard 4-20mA input or a digital HART input from a transmitter, the MCU900 control unit will provide the following functions :

- Calculation and display of the MCU900 Primary Variable (PV).

The user can choose this to be the reading coming from the transmitter, which may be a depth or distance measurement from a HART ultrasonic transmitter or may be a mA reading from a pressure transmitter, or some other value calculated by the MCU900 based on the transmitter input, which could be a level, distance, contents or flow reading. A totaliser function is also included.

The MCU900 is factory programmed with a set of standard volumetric and flow equations to convert a level signal to contents or flow, and also has a 21 point user programmed look-up table for non-standard applications.

MCU902 units calculate the difference, sum or product of 2 separate 4-20mA inputs.

MCULOG units have a 4800 event on board logging capability.

MCU90F units have a 7200 event on board logging capability and twin totalisers.

- 4-20mA signal out from the MCU900 control unit.

The MCU900 current output is usually proportional to the displayed PV, and is displayed in bargraph form on the display (0-100%).

- Relay control functions.

There are 5 freely assignable relays. Relay 5 is a fault relay by default, which may be assigned to control duty if required. The other 4 relays are available for the user to programme to operate at chosen values of the displayed PV, or other calculated values.

The MCU900 is factory programmed with a selection of popular pump control routines for wet well and sump control, along with energy saving over-rides.

- Voltage free (digital) contact input

Up to two voltage free contact closure inputs may be connected, allowing external over-ride of control unit functions if desired.

- Programming a transmitter from the MCU900 control unit

As the MCU900 will communicate digitally with any HART compatible transmitter powered by the MCU900, it is possible to programme a HART transmitter using the MCU900 keypad.

Full communication with Mobrey Measurement HART ultrasonic transmitters, allowing access to all transmitter parameters is supported, whilst Universal and some Common Practice commands of other HART transmitters is possible in accordance with HART protocol.

2.0 Mobrey MCU900 Series Controller

2.1 Display and Keypad

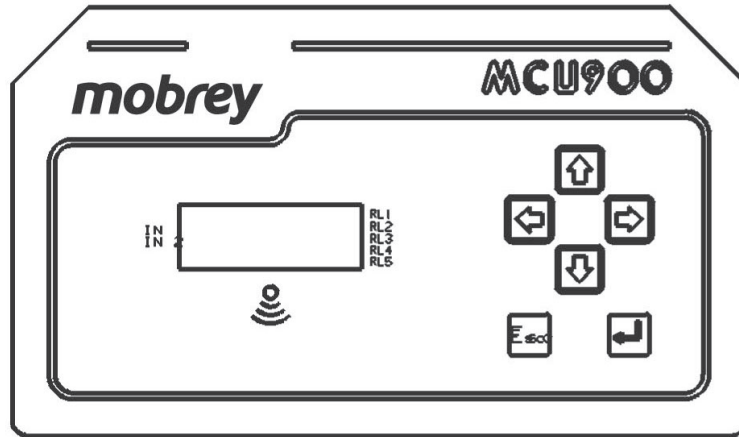

Figure 1 : MCU900 keypad and LCD display

The MCU900 display is fully field configurable and may be customised to suit the requirements of the user.

Typically the 4 line display is as shown in Figure 2, The top line shows whether the programme lock is open together with the time display. The actual measurement, the MCU900 Primary Variable (PV) is displayed in the centre using double height characters. The lower line shows a bargraph representation of the 4-20mA current output of the control unit, proportional to the PV, 0-100%.

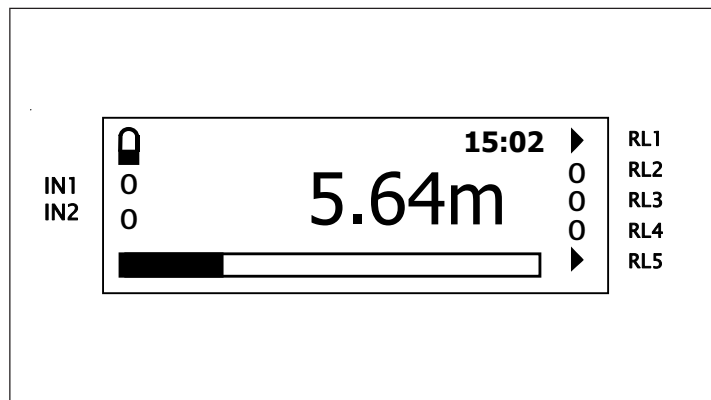

Figure 2 : Typical MCU900 liquid crystal display

Additional flags on the display show the status of the five relay outputs, RL1 to RL5, and of the digital control inputs into the MCU900.

Keypad Operation :

There are 6 buttons on the MCU900 front panel. The four ARROWS allow navigation around the programming menu and the "ESC" and "↵" buttons allow movement from one screen to the next. By pressing "ESC" repeatedly, the screen will always return to the normal display as shown in Fig 2. Movement through the menu structure using the arrows is shown by the titles being "highlighted", ie reversed to show white letters on a dark background. The LCD is backlit for operator convenience. (This can be turned off if required).

Some basic introductory programming details are given in Appendix 1, whilst full programming and operating instructions are given in Manual IP2030/OM. Quickstart manuals, are also available, covering use of the MCU900, MCU902, MCULOG and MCU90F with a Mobrey Measurement ultrasonic transmitter(s).

2.2 Type Numbering System

MCU	Mobrey Control Unit
901	Standard model
902	Differential model
LOG	Logging model
90F	Open channel flow model
WX	Wall mounting
-U	UL certified, 115V ac/230V ac mains powered

2.3 Safety Data

Type numbers	See above
Certification	UL listed to USA & Canadian standards Intrinsically Safe Associated Equipment
Coding	Class 1 Division 1 Groups A, B, C & D Class 1 Zone 0 IIC (-40°C ≤ Ta ≤ 55°C)
Safety Parameters	Intrinsically safe associated equipment



Terminal 1 (24V) w.r.t. terminal 2 (lin) Terminal 1 (24V) w.r.t. terminal 3 (Earth)	Terminal 2 (lin) w.r.t. terminal 3 (Earth)
$U_i = 0$ $U_o (Voc) = 27.3V$ $I_o (Isc) = 96.9mA$ $P_o = 0.66W$ $L_o (L_a) = 2.26mH$ $C_o (C_a) = 0.070\mu F$	$U_i = 30V$ $I_i = 120mA$ $L_i = 0.1mH$ $C_i = 0.6nF$ $U_o = 6.51V$ (Cap. charging only) $I_o = 0$ $P_o = 0$

The capacitance and inductance of the cable and equipment connected to the intrinsically safe output terminals must not exceed the following values :

Group	Capacitance	Inductance
A, B (IIC)	0.070* μF	2.26mH
C (IIB)	0.546 μF	9.8mH
D (IIA)	1.82 μF	19.8mH

* 0.070 μF of which total C_i of the hazardous area apparatus connected must not exceed 0.020 μF .

Terminal 2 (I_{IN}) w.r.t. Terminal 3 (Earth) must be treated as a 6.51V source. The 6.51V is considered as being the theoretical maximum to which a capacitive load across these terminals could become charged through leakage through internal series blocking diodes. This voltage does not contribute to the short circuit sparking risk of any external source connected to these terminals.

2.4 Electrical Specifications

Cable connections	Cage clamp terminal block, suitable for 2.5mm ² max cable.
Supply voltage	Switch selected : Mains - 115Vac, voltage range 98Vac - 126.5Vac 50-60Hz Mains - 230Vac, voltage range 196Vac - 253Vac 50-60Hz
Power consumption	Mains - 10VA at nominal supply voltage Mains - 18VA Max.
Fuse	Mains - 200mA (T) 5 x 20mm 250V, Littelfuse type 218.200
Transmitter input	4-20mA (Earth referenced in MCU900) CAT 1 30V dc Max.
Digital inputs	Unit accepts two trigger input signals. (Voltage free contact closure)
Relay Outputs	5 x SPCO Relays, rated 5 Amp at 240 Vac Resistive Please refer to section 3.7 for safety use.
Current Output	4-20 mA isolated into 1k Ω max. If externally powered then max. voltage is 30Vdc
DC Power Output	24V DC for transmitter, 25mA max. load
HART	HART digital communications to transmitter

See "WARNING" in section Safety Precautions on Page 2

3.0 MCU900 Control Unit Installation

The control unit must not be mounted in areas where an explosion hazard exists.



If connecting the MCU900 to a 4-20mA transmitter located in a hazardous area, refer also to instructions on page 6 and control drawing 71097/1121 on page 26.

Refer also to the important safety precautions detailed at the start of this manual.

3.1 Environmental Specification

Ambient temperature	-40°C to 55°C
Max Altitude	2000m
Max Humidity	100% RH
Electrical Safety	Conforms to EN61010-1 and UL508
Installation over voltage Category	III
Pollution Degree	4

3.2 MCU900W Wall Mounting models

The control unit housing is rated IP65 / NEMA 4X. It is suitable for mounting outside, but this should be above any flood level, away from any overflow water path, and away from direct sunlight. Do not mount the MCU900W on a structure that is subject to vibration, or in a position where damage may be caused by impact, thermal stress or liquid ingress.

The mass of the MCU900W is 3.5kg. To conform with safety requirements, the wall on which the MCU900W is mounted should be capable of supporting 4 times this weight.

It is not necessary or advisable to remove the panel to the upper part of the panel, containing the LCD and keypad. There are no user serviceable parts inside. The control unit must not be modified in any way. Mount the unit on a suitable wall or structure using the 4 fixing points as shown in figure 3.

The MCU900W is not supplied with cable entries for connections to the field mounted transmitter and the mains power supply. MCULOG and MCU90F have an additional connector which is used to download logged data.

It is the responsibility of the user to ensure that cable glands and connection to the MCU900W are in accordance with local or national standards. To maintain the type 4X rating of the enclosure type 4X connections must be used.

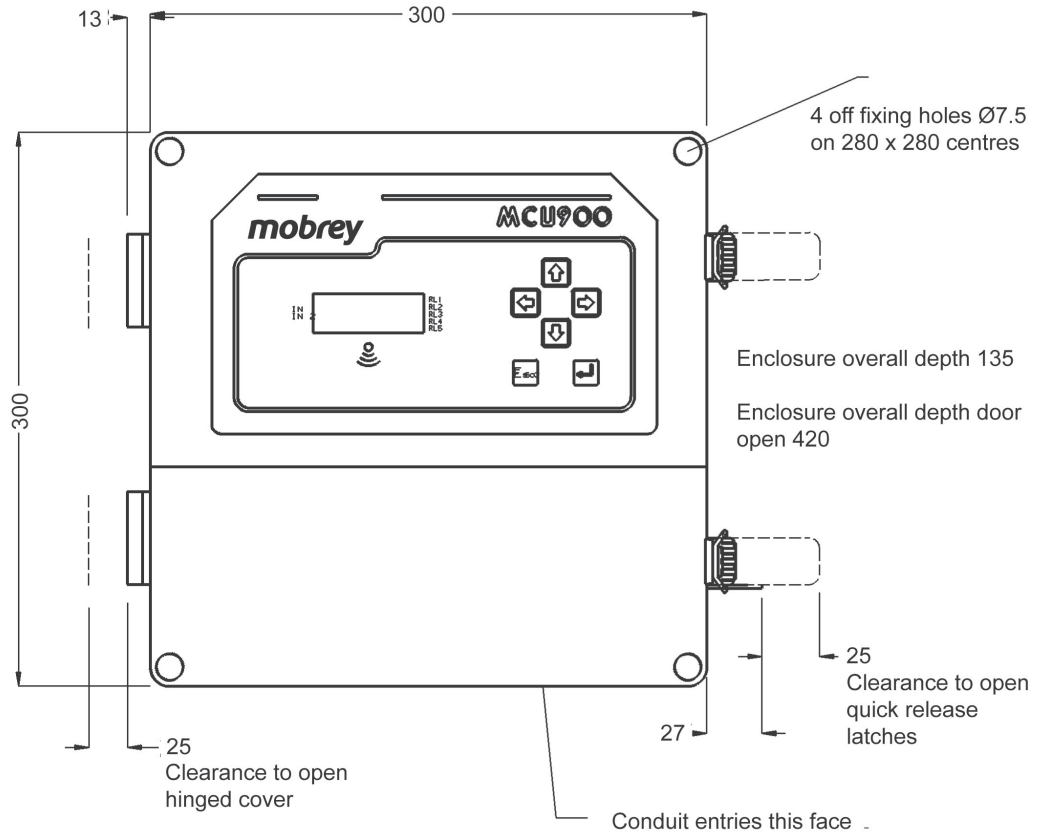

Figure 3 : MCU900W Control Unit Dimensions

3.2.1 Electrical Connections : MCU900W Wall mounting models

All field wiring connections are accessible by removing the lower terminal cover, which is secured by four screws. Note that it is the responsibility of the installer to observe all local regulations and approval requirements, and to ensure wiring is suitable for the load current and the insulation is suitable for the voltage, temperature and environment of the installation. Obtain and check any hazardous area work permits required before applying power to the MCU900. On no account should the mechanical barriers separating the terminal area from the main enclosure and the transmitter terminals from the other terminals be removed or modified.

The diagram below shows the layout of external connection terminals: all terminal blocks are suitable for wires 14 to 26 AWG (0.5mm² to 1.5mm²) (10 AWG/2.5mm² for mains terminals). Insulation should be stripped back ¼" (7mm). For field wiring use 75°C/167°F copper conductors only.

It is the responsibility of the user to ensure suitable cable glands or conduit connections are used when wiring to the MCU900 to maintain the enclosure integrity. Protective earth cables must be connected to at least one of the bonding points on the inside of the enclosure. Bonding between conduit entries is not automatic and must be provided as a part of the installation. MCULOG has a data download socket factory fitted.

Note that in intrinsically safe systems, apparatus connected to the MCU900 must not be supplied from a voltage greater than 250V rms or 250V DC.

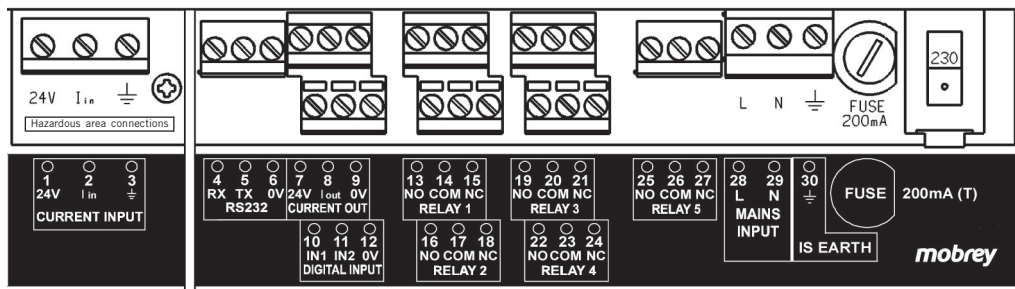

Figure 4: Connection Terminal Layout (mains version shown)

Note that not all of the terminals are labelled on the pcb - a wiring label is positioned in the terminal area.

The transmitter connections are on the left side of the terminal enclosure.

The I.S. Earth (Terminal 30) must be connected to an Intrinsically Safe Earth if the transmitter connected to terminals 1 and 2 is located in a hazardous area.

Terminal	Function	Layout	Terminal Torques
1	Loop supply	24V	For terminal tightening torques refer to label inside the terminal area.
2	Current Input	Iin	
3	Screen	⊥	
4-6	RS232	RX-TX-0V	
7-9	Current Output	24V- Iout-0V	
10-12	Digital Input 1 & 2	IN1-IN2-0V	
13-15	Relay 1	NO-COM-NC	
16-18	Relay 2	NO-COM-NC	
19-21	Relay 3	NO-COM-NC	
22-24	Relay 4	NO-COM-NC	
25-27	Relay 5	NO-COM-NC	
28-29	Mains Input	L-N (mains version only)	
30	IS Earth	⊥	

3.3 Notes on transmitter installation and cabling



Connection of a transmitter to the MCU900 does not confer Intrinsic Safety on the transmitter. It is the responsibility of the user to ensure any transmitter installed in a hazardous area is suitable for use and certified accordingly for use in the hazardous area. The installation should be in accordance with a recognised code of practice.

Check the parameters of the installed system of MCU900, transmitter, any loop devices and interconnecting cable to ensure compliance with the individual product certificates and technical data (Refer to page 6).

Particular attention must be given to the cable and the transmitter to ensure that the total capacitance and inductance limits stated in the MCU technical data in Section 2.3 are not exceeded.

Cable joins are allowable in cabling to the transmitter provided that the joint is made within an IP20 / NEMA 3 (minimum) enclosure suitable for the environment, and that the wiring withstands a test voltage of 500V r.m.s. to earth.

The maximum length of cable permissible between the transmitter and MCU900 is determined by the limits imposed by the intrinsically Safe certificates of the instruments and control drawing 71097/1121.

No other outputs from the MCU900 must be routed through a hazardous area unless protected by an additional I.S. Barrier.

It is the responsibility of the user to ensure that any transmitter is installed in accordance with the manufacturer's instructions supplied with the transmitter.

Cable between the MCU900 and the transmitter should be twisted pair shielded with the shield connected to terminal 3 marked "⏚" in the MCU900. The shield should be left unconnected at the transmitter unless there is a terminal specifically provided for this purpose.

Cable runs should be separate from any high voltage or mains cables to avoid crosstalk or interference.

Multicore cable may be used provided that other cores carry only low voltage (24V dc nom) signals and each pair of cores is individually shielded.

Loop powered transmitters must be connected to terminals 1 - 3 as shown below :

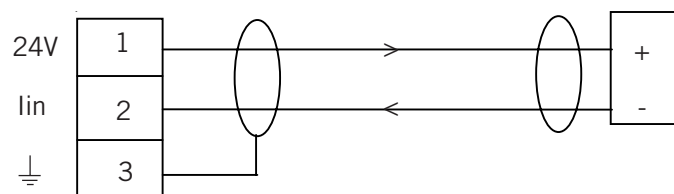

Figure 8

The MCU900 is able to provide 24V dc to a transmitter with a max load of 25mA.

Separately powered transmitters must be connected to terminals 2 and 3 as shown below :

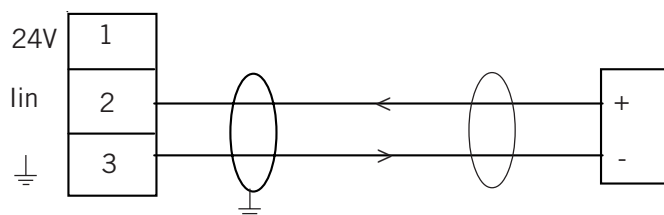

Figure 9

3.3.1

Special notes for connecting HART transmitters (including MSP900SH-U transmitters) to the MCU902 Control Unit.

The MCU902 Control Unit takes the input from two HART transmitters and will perform various calculations to create the sum, difference or product of the two inputs.

The transmitters must be HART compatible for the MCU902 to operate correctly.

Connection of the transmitters to the MCU902 may be by cabling both transmitter cables into the MCU902 or may be on a single cable with the two transmitters connected to this cable in a suitable local junction box.

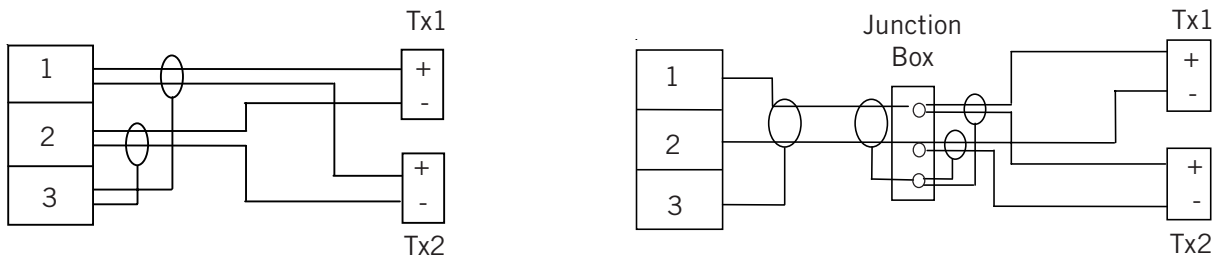

MCU902 to transmitter connection

For correct operation, each transmitter must be changed to “multi-drop” mode so that they can communicate with the MCU902 through a common connection. Each transmitter must therefore have its poll address changed from the factory default address of “0” to a unique address. The MCU902 is used to achieve this, but this requires that the transmitters be connected in sequence as detailed below :-

- a) With the power supply turned off, connect the first transmitter to terminals 1-3 in the MCU902 control unit.
- b) Check that the power selector switch is set to the correct voltage (115 or 230 V ac) on mains unit and turn the power supply on.
- c) The MCU902 will detect the transmitter and automatically change the poll address of the transmitter from “0” to “1”. This transmitter will also be automatically allocated to Channel 1 of the MCU902.

Note, the MCU902 control unit may also offer the user the opportunity to set the bottom reference of the MSP900SH-U transmitter at this point, which may be done or ignored by pressing the “Esc.” Key.

- d) Turn the power supply off and connect the second transmitter, either at the same terminals 1-3 as the first transmitter or at a local junction box, such that both transmitters are now connected.
- e) Turn the power supply back on and the MCU902 will once again search for and detect any transmitters connected. Once the second transmitter is found, the MCU902 will automatically change the poll address from “0” to “2”, and the transmitter will also be automatically allocated to Channel 2 of the MCU902.

Note, the MCU902 control unit may also offer the user the opportunity to set the bottom reference of the MSP900SH-U transmitter at this point, which may be done or ignored by pressing the “Esc.” Key.

Installation of the transmitters is now complete.

3.4 Power connection

If the MCU900 is powered by mains AC power, select the AC voltage to 230V or 115V as required using the voltage selector slide switch.

A switch or circuit breaker should be installed in close proximity to the instrument, and labelled as such.

Although the MCU900 meets all European standards for surge immunity on power and signal lines, it is recommended that lightning suppressors, such as made by Telematic Ltd., are fitted if local conditions make this advisable.

3.5 Earthing

Wall mounted MCU900 must be connected to the main earth, bonded to at least one of the earth points inside the terminal area. Bonding between conduit entries is not automatic and must be provided as a part of the installation.

DO NOT connect a mains earth to terminal 30.



Terminal 30 is provided for use as an Intrinsically Safe (or functional) earth connection which **MUST** be used when a transmitter is mounted in a hazardous area and is connected to terminals 1 & 2.

Terminal 3 is to be used for connection of the shield of the twisted pair transmitter cable when the MCU900 is powering the transmitter. See Fig. 8 and 9. Note that this shield should be left unconnected at the transmitter end unless there is a terminal provided specifically for this purpose.

3.6. Relays

The 5 voltage free contact relays are grouped in the following configuration :

MCU900W Wall Mount Control Unit		
Relay 1 & 2	-	Group 1
Relay 3 & 4	-	Group 2
Relay 5	-	Group 3

The relay NO-C-NC labels represent the relay terminals in the de-energised state.

Note that, whilst each relay is individually double insulated, their arrangement is such that insulation between relays in the same group is standard or 'basic' insulation.

Care must be taken in order to avoid the risk of electric shock. It is not allowed to use relays in the **same Group** to control circuits with both mains and dc or low voltage circuits.

3.7 Current Output

The current output may be connected in internally powered mode or loop-powered mode. See connections in Fig 10 below.

In Loop-powered mode an external power source is required. A minimum of 2.5V is required across terminals 7 and 8 for correct operation. The external voltage must not be more than 30V dc.

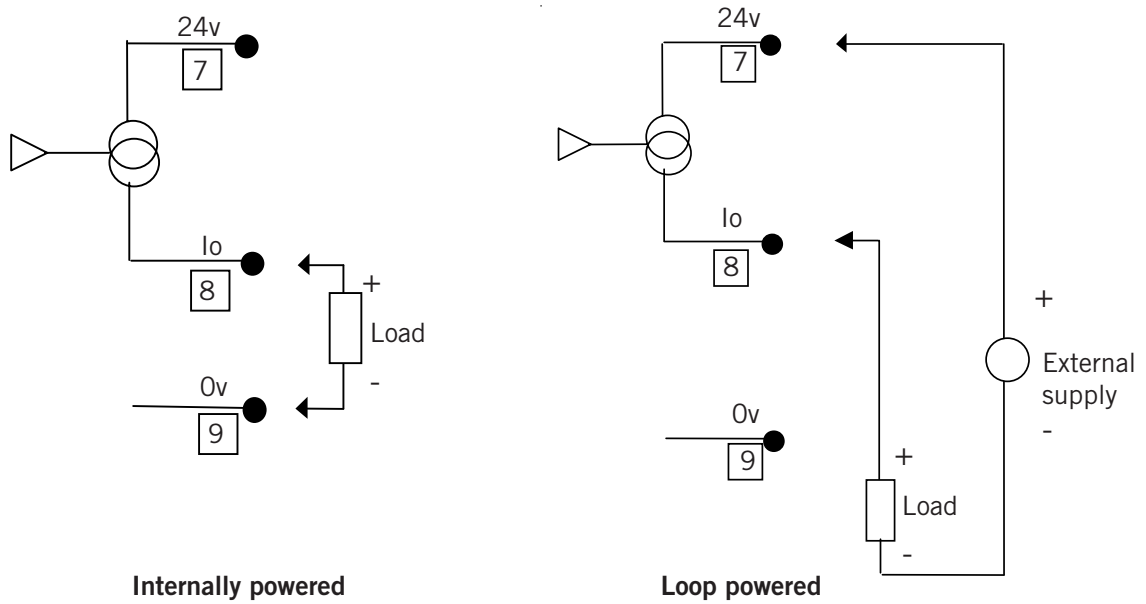

Figure 10 : Alternative current output configurations

3.8 Digital Control Voltage free contact inputs

There are 2 trigger inputs IN1 and IN2. The digital trigger input is connected as shown below:

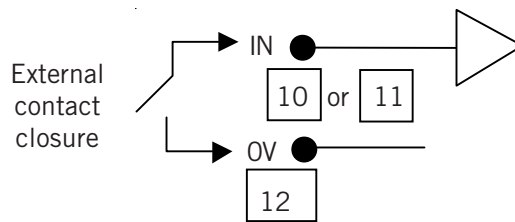

Figure 11 : Connection for external trigger input

3.9 RS232

The RS232 connections (Terminals 4-6) may be used for exchanging data with a PC or handheld device. The configuration of the Control Unit may be read or modified using an application such as Mobrey H-Conf401 running on a PC.

For the MCULOG & MCU90F, the logged data is downloaded from the RS232 port via a socket connection provided, using Mobrey LogView running on a PC.

4	Rx
5	Tx
6	OV

4.0 Maintenance / Inspection

CONTROL UNIT

Before servicing disconnect power to prevent ignition of flammable or combustible atmospheres
Substitution of components may impair intrinsic safety.

No maintenance is required beyond occasional cleaning of the enclosure with a damp cloth. Solvents or bleaches should not be used. Do not modify or attempt to repair the unit.

Check lid and glands/conduit connections are tight, also check unit for damage and if damaged do not use.

APPENDIX 1

Introduction to programming the MCU900

The following few pages give a brief introduction to programming the MCU900. More detailed information is given in the Operation Manual IP2030/OM, available from Mobrey Measurement or by download from the Mobrey Measurement website at www.mobrey.com

A1 The MCU900 keypad and menu navigation

The 4 red/white arrow keys are used to move around the menu structure, and the yellow enter key to confirm data input. The red Esc key allows a backward step to the previous screen.

Practice now using the keypad to customise the system settings in the MCU900. You may like to set the date, time and language of the display.

- Press the enter key to display the Main Menu.
- Press the down arrow once to highlight "SETUP" and press the enter key. (Note the beep which confirms each key press)
- Select "MCU CONTROL UNIT" and press the enter key to reveal the "SETUP" menu.
- Use the down arrow to move down the list. Note that there are more than the three items shown in the list, as indicated by an arrow pointing down in the lower right of the screen. Highlight "SYSTEM" and press the enter key.
- The SYSTEM menu comprises 6 items. Press the down arrow several times, or the right arrow once, to highlight "SETTINGS" and press the enter key.
- Select "Time" and press the enter key. You may now edit the time if appropriate.
- Press the enter key which will highlight the first "hours" digit. Use the up and down arrows to select the correct value then press the right arrow to move to the next digit. Continue until the time shown is correct, then press the enter key to save the time shown. Press Esc to jump back to the "SETTINGS" screen and select another setting to customise as appropriate, for example, display language.
- Once the MCU900 has been customised to your satisfaction, press the Esc key repeatedly to return to the main display screen.
- After completion of programming close and secure enclosure cover.

A2 Programming the MCU900 for your application

The MCU900 is capable of complex control functionality, much of which is specific to certain duties. To programme the MCU900 for a specific application, it has to be told what the application is and then certain application details to allow the MCU900 to perform the necessary calculations.

To assist the user in understanding MCU900 programming, it is convenient to imagine these application specific data to be stored in memory locations called "Parameters", each of which has a unique address. Not all parameters are necessary for each application.

Programming the correct parameters for your particular application is made easy by Mobrey Measurement "Wizards", which navigate the user around the menu structure and request only the data needed for your chosen application.

A listing of the MCU900 parameters, their location in the menu structure and their units / default values is given at the rear of this manual. Also, the parameter listing for the Mobrey Measurement MSP900SH is given, as this is a popular choice of transmitter to use with this MCU900 control unit.

You are strongly recommended to use these Wizards whenever possible.

Before the Mobrey Measurement wizards are explained in more detail, it is important that the user understands the input to the MCU900 and what is being shown on the display.

A2.1 Understanding the input to the MCU900 and what is shown on the display.

The MCU900 may be used with either a 4-20mA transmitter or a digital HART transmitter.

A2.1.1 Using a transmitter with a standard 4-20mA output.

Any transmitter with a 4-20mA output may be connected to the MCU900.

Exactly what this 4-20mA represents is a function of the transmitter. The transmitter can not be re-ranged by the MCU900.

For example, if a level transmitter designed to give a 4-20mA output over 5m is installed in a 3m deep tank, the input to the MCU900 is going to be 4-13.6mA.

When a standard 4-20mA transmitter is connected, the MCU900 will recognise the input and the PV shown on the main display will be in % of current input, where 4mA is 0% and 20mA is 100%. Note, in the example above, the maximum current that the MCU900 will see will be 13.6mA, so the PV on the display will only ever show 60% maximum.

It is possible to scale this input in the MCU900 and give a 4-20mA output from the MCU900.

A2.1.2 Using a HART compatible transmitter

Any HART compatible transmitter can be connected to the MCU900.

The MCU900 will recognise a HART transmitter and automatically start digital communications. The PV shown on the display will be extracted directly from the transmitter, along with the associated measurement units.

You will notice a small “~” icon next to the padlock in the upper left corner of the display which shows digital communications are in operation.

A2.1.3 Using the MCU902

The MCU902 accepts inputs from two HART transmitters arranged in multi-drop mode.

Transmitters **MUST BE** HART compatible to be used with the MCU902. See Section 3.4.1.

A2.2 Using Mobrey Measurement Wizard assisted programming

With a transmitter connected and operating, you should now tell the MCU900 what duty it is to perform – Wet well pump control, Level measurement, Contents measurement or Flow measurement.

- Press enter and navigate to the Duty Wizard selection screen “SETUP / MCU900 CONTROL UNIT / DUTY (mode) / Duty Wizard.
- Press enter to start the duty wizard and select the duty for the MCU900
- Enter data as requested by the MCU900, which will automatically set up the input scaling and current output of the MCU900.

At the end of any duty wizard you will automatically be offered further wizards which are appropriate to you chosen application. For example, the “MCU Relay WIZARD”, which allows you to set up relay control or alarm points as required, or the “TOTALISER WIZARD” relevant to open channel flow measurement and totalisation.

Further details of Mobrey Measurement Wizards are given in the system Quickstart manual IP2040/QS/UL and the technical manual IP2030/OM available on request or from the website.

A2.3 Useful programming information

The following information is given to assist users in programming other popular functions of the MCU900.

A2.3.1 Password protection

The MCU900 may be protected from unauthorised programming by setting a PIN number.

Follow the path “SETUP / MCU CONTROL UNIT / SYSTEM / SETTINGS / PIN” and enter a 4 digit PIN.

A2.3.2 Configure the display

The MCU900 display may be customised to show a variety of data. The display is sectioned into 3 horizontal zones, Upper, Middle and Lower.

Follow the path “SETUP / MCU CONTROL UNIT / OUTPUT / DISPLAY” and select which part of the display you wish to customise. You may then select from a list of data which may be displayed there.

A2.3.3 Set up a digital input

Two voltage free contact inputs may be connected to the MCU900 and be programmed to cause certain actions should they activate.

Follow the path “SETUP / MCU CONTROL UNIT / DIGITAL INPUT / Digital Input 1 “ and you can then customise the input to suit your requirements.

A2.3.4 Commissioning aids

The MCU900 has several useful commissioning aids on-board.

Follow the path “SETUP / MCU CONTROL UNIT / SYSTEM / TEST “ and you can choose to autcycle the MCU900 over the full range of the current input without changing the transmitter input or level in a tank, trim input and output currents or use the MCU to drive a set output current into the loop.

A2.3.5 Re-setting default values

If the MCU900 is not operating as you would expect or you are unsure of some of the data you have programmed in, you can re-set the MCU900 to it's factory default condition. This action causes default values to be loaded into all of the MCU900 parameter locations. Note, all previously entered data will be overwritten or lost.

Follow the path “SETUP / MCU CONTROL UNIT / SYSTEM / DEFAULTS” and follow the instruction to load defaults.

A2.3.6 Direct parameter access

Proficient users who become familiar with the parameter numbers of the MCU900 can access parameters directly by parameter number.

Follow the path “DIRECT” and select either Pxxx or Dxxx. “D” type parameters are diagnostic parameters and are read only.

Once a parameter number is entered and displayed, the user can use the up and down keys to scroll through the full parameter list.

A2.3.7. Programming menus

A2.3.7.1 Menu structure and parameter list for the MCU901/MCULOG

Function Menu Option	Sub-menu Level 1	Sub-menu Level 2	Sub-menu Level 3	Par No.	Parameter Name	Units	Default
Cancel Password					Cancel Password	-	-
Go Offline ?					Go Online/Offline ?	-	-
SETUP	INPUT CHANNEL			P111	Channel 1 Input Source	-	Tx1 : PV
				P321	Current Input 1 Damping	sec	5
				P112	Channel 1 Input Offset	-	0
				P113	Channel 1 Profile	-	Scaled
				P114	Channel 1 Input Scale Factor	-	1
				P115	Channel 1 Non-Linear Data	-	0
				P116	Channel 1 Post Scale	-	1
				P117	Channel 1 Low Cut-off	as P201	AUTO
	DUTY(Mode)				Duty Wizard	-	0
		UNITS		P200	PV Units	-	%
				P201	SV Units	-	%
				P202	TV Units	-	%
				P203	FV Units	-	°C
		PV DAMPING		P210	Output PV Damping	s	0
				P240	Description	-	MCU CONTROL
				P241	Message	-	MESSAGE
				P242	Tag Number - Control Unit	-	MSP2000
		CUSTOM		P250	Start On	-	None
				P251	Stop On	-	None
				P252	Stop If	-	None
				P253	Start Time	hh.mm	07:00
				P254	Interval	hh.mm	01:00
				P255	Start Time #2	hh.mm	00:00
				P256	Interval #2	hh.mm	00:00
				P257	Max Retries	-	10
		OVERRIDES		P270	Auto Sequence Enable	-	Off
				P271	Auto Sequence Qualifier	-	0
				P272	Pump-down Relay	-	0
				P273	Pump-down Interval	hh.mm	00:00
				P274	Pump-down Duration	hh.mm	00:00
				P275	Energy Saving Start Time	hh.mm	00:00
				P276	Energy Saving Relay Select	-	0
				P277	Scum Line Prevention variance	-	0
				P278	Scum Line Prevention relay	-	0
	DIGITAL INPUT	DIGITAL INPUT 1		P340	Digital Input 1 Action	-	Free
				P341	Digital Input 1 Delay	mmm:ss	000:00
				P342	Digital Input 1 On State	-	Closed
		DIGITAL INPUT 2		P345	Digital Input 2 Action	-	Free
				P346	Digital Input 2 Delay	mmm:ss	000:00
				P347	Digital Input 2 On State	-	Closed
	OUTPUT	CURRENT OUTPUT		P400	Lower range value	as P200	0
				P401	Upper range value	as P200	100
				P402	Alarm action	-	3.6mA
		RELAY			Relay Wizard	-	0
					Reset RL Params	-	0
		RELAY 1		P410	Relay 1 Mode	-	None
				P411	Relay 1 PV ON Point	as P200	0
				P412	Relay 1 PV OFF Point	as P200	0
				P413	Relay 1 Minimum ON Time	mmm:ss	000:00
				P414	Relay 1 Maximum ON Time	mmm:ss	000:00
				P415	Relay 1 Minimum OFF Time	mmm:ss	000:00
		RELAY 2		P420	Relay 2 Mode	-	None
				P421	Relay 2 PV ON Point	as P200	0
				P422	Relay 2 PV OFF Point	as P200	0
				P423	Relay 2 Minimum ON Time	mmm:ss	000:00
				P424	Relay 2 Maximum ON Time	mmm:ss	000:00
				P425	Relay 2 Minimum OFF Time	mmm:ss	000:00
		RELAY 3		P430	Relay 3 Mode	-	None
				P431	Relay 3 PV ON Point	as P200	0
				P432	Relay 3 PV OFF Point	as P200	0
				P433	Relay 3 Minimum ON Time	mmm:ss	000:00
				P434	Relay 3 Maximum ON Time	mmm:ss	000:00
				P435	Relay 3 Minimum OFF Time	mmm:ss	000:00
		RELAY 4		P440	Relay 4 Mode	-	None
				P441	Relay 4 PV ON Point	as P200	0
				P442	Relay 4 PV OFF Point	as P200	0
				P443	Relay 4 Minimum ON Time	mmm:ss	000:00
				P444	Relay 4 Maximum ON Time	mmm:ss	000:00
				P445	Relay 4 Minimum OFF Time	mmm:ss	000:00
		RELAY 5		P450	Relay 5 Mode	-	Fault
				P451	Relay 5 PV ON Point	as P200	0
				P452	Relay 5 PV OFF Point	as P200	0
				P453	Relay 5 Minimum ON Time	mmm:ss	000:00
				P454	Relay 5 Maximum ON Time	mmm:ss	000:00
				P455	Relay 5 Minimum OFF Time	mmm:ss	000:00
		ALARM		P490	Rising level alarm delay	mmm:ss	000:00
				P491	Relay operations	-	0
				P492	Relay operations relay select	-	Disabled
				P493	Relay runtime	hh.mm	00:00
				P494	Relay runtime relay select	-	Disabled
				P495	Pump efficiency limit	-	0
				P496	Pump Efficiency relay select	-	0
				P497	No activity delay	hh.mm	00:00
				P498	No activity relay	-	0

A2.3.7.2 Menu structure and parameter list for the MCU902

Function Menu Option	Sub-menu Level 1	Sub-menu Level 2	Sub-menu Level 3	Par No.	Parameter Name	Units	Default		
Cancel Password					Cancel Password	-	-		
Go Offline ?					Go Online/Offline ?	-	-		
SETUP	PV CALCULATION	CHANNEL 1		P111	Channel 1 Input Source	-	Tx1 : PV		
				P112	Channel 1 Input Offset	-	0		
				P113	Channel 1 Profile	-	Scaled		
				P114	Channel 1 Input Scale Factor	-	1		
				P115	Channel 1 Non-Linear Data	-	0		
				P116	Channel 1 Post Scale NLP	-	1		
				P117	Channel 1 Low Cut-off	as P201	AUTO		
			CHANNEL 2		P121	Channel 2 Input Source	-	Tx2 : PV	
				P122	Channel 2 Input Offset	-	0		
				P123	Channel 2 Profile	-	Scaled		
				P124	Channel 2 Input Scale Factor	-	1		
				P125	Channel 2 Non-Linear Data	-	0		
				P126	Channel 2 Post Scale NLP	-	1		
				P127	Channel 2 Low Cut-off	as P202	AUTO		
			>		P150	Output Mapping	-	Ch1	
			>		P151	MCU Fourth Variable Source	-	Tx1 : FV	
			>		P321	Current Input 1 Damping	sec	5	
	DUTY(Mode)	>				Duty Wizard	-	0	
		UNITS			P200	PV Units	-	%	
					P201	SV Units	-	%	
					P202	TV Units	-	%	
					P203	FV Units	-	°C	
		PV DAMPING			P210	Output PV Damping	s	0	
		>			P240	Description	-	MCU CONTROL	
		>			P241	Message	-	MESSAGE	
		>			P242	Tag Number - Control Unit	-	MSP2000	
		CUSTOM				P250	Start On	-	None
						P251	Stop On	-	None
						P252	Stop If	-	None
						P253	Start Time	hh.mm	07:00
						P254	Interval	hh.mm	01:00
						P255	Start Time #2	hh.mm	00:00
						P256	Interval #2	hh.mm	00:00
						P257	Max Retries	-	10
	OVERRIDES					P270	Auto Sequence Enable	-	Off
						P271	Auto Sequence Qualifier	-	0
					P272	Pump-down Relay	-	0	
					P273	Pump-down Interval	hh.mm	00:00	
					P274	Pump-down Duration	hh.mm	00:00	
					P275	Energy Saving Start Time	hh.mm	00:00	
					P276	Energy Saving Relay Select	-	0	
					P277	Scum Line Prevention variance	-	0	
					P278	Scum Line Prevention relay	-	0	
		DIGITAL INPUT	DIGITAL INPUT 1			P340	Digital Input 1 Action	-	Free
						P341	Digital Input 1 Delay	mmm:ss	000:00
					P342	Digital Input 1 On State	-	Closed	
	DIGITAL INPUT 2				P345	Digital Input 2 Action	-	Free	
					P346	Digital Input 2 Delay	mmm:ss	000:00	
					P347	Digital Input 2 On State	-	Closed	
	OUTPUT	CURRENT OUTPUT			P400	Lower range value	as P200	0	
					P401	Upper range value	as P200	100	
					P402	Alarm action	-	3.6mA	
RELAY						Relay Wizard	-	0	
						Reset RL Params	-		
		RELAY 1			P410	Relay 1 Mode	-	None	
					P411	Relay 1 PV ON Point	as P200	0	
					P412	Relay 1 PV OFF Point	as P200	0	
					P413	Relay 1 Minimum ON Time	mmm:ss	000:00	
					P414	Relay 1 Maximum ON Time	mmm:ss	000:00	
					P415	Relay 1 Minimum OFF Time	mmm:ss	000:00	
		RELAY 2			P420	Relay 2 Mode	-	None	
					P421	Relay 2 PV ON Point	as P200	0	
					P422	Relay 2 PV OFF Point	as P200	0	
					P423	Relay 2 Minimum ON Time	mmm:ss	000:00	
					P424	Relay 2 Maximum ON Time	mmm:ss	000:00	
					P425	Relay 2 Minimum OFF Time	mmm:ss	000:00	
		RELAY 3			P430	Relay 3 Mode	-	None	
					P431	Relay 3 PV ON Point	as P200	0	
					P432	Relay 3 PV OFF Point	as P200	0	
				P433	Relay 3 Minimum ON Time	mmm:ss	000:00		
				P434	Relay 3 Maximum ON Time	mmm:ss	000:00		
				P435	Relay 3 Minimum OFF Time	mmm:ss	000:00		
RELAY 4			P440	Relay 4 Mode	-	None			
			P441	Relay 4 PV ON Point	as P200	0			
			P442	Relay 4 PV OFF Point	as P200	0			
			P443	Relay 4 Minimum ON Time	mmm:ss	000:00			
			P444	Relay 4 Maximum ON Time	mmm:ss	000:00			
			P445	Relay 4 Minimum OFF Time	mmm:ss	000:00			

		RELAY 5	P450	Relay 5 Mode	-	Fault
			P451	Relay 5 PV ON Point	as P200	0
			P452	Relay 5 PV OFF Point	as P200	0
			P453	Relay 5 Minimum ON Time	mmm:ss	000:00
			P454	Relay 5 Maximum ON Time	mmm:ss	000:00
			P455	Relay 5 Minimum OFF Time	mmm:ss	000:00
		ALARM	P490	Rising level alarm delay	mmm:ss	000:00
			P491	Relay operations	-	0
			P492	Relay operations relay select	-	Disabled
			P493	Relay runtime	hh:mm	00:00
			P494	Relay runtime relay select	-	Disabled
			P495	Pump efficiency limit	-	0
			P496	Pump Efficiency relay select	-	0
			P497	No activity delay	hh:mm	00:00
			P498	No activity relay	-	0
		TOTALISER		Totaliser Wizard	-	0
			P530	Totaliser 1 Factor	-	0
			P531	Totaliser 1 Units	-	None
			P532	Totaliser 2 Factor	-	0
			P533	Totaliser 2 Units	-	None
			P536	Totaliser 2 Source	-	None
			P534	Totaliser Pulse width	ms	100
			P535	Sampler Factor	-	0
		ALARM	P490	Rising level alarm delay	mmm:ss	000:00
			P491	Relay operations	-	0
			P492	Relay operations relay select	-	Disabled
			P493	Relay runtime	hh:mm	00:00
			P494	Relay runtime relay select	-	Disabled
			P495	Pump efficiency limit	-	0
			P496	Pump Efficiency relay select	-	0
			P497	No activity delay	hh:mm	00:00
			P498	No activity relay	-	0
		TOTALISER		Totaliser Wizard	-	0
			P530	Totaliser 1 Factor	-	0
			P531	Totaliser 1 Units	-	None
			P532	Totaliser 2 Factor	-	0
			P533	Totaliser 2 Units	-	None
			P536	Totaliser 2 Source	-	None
			P534	Totaliser Pulse width	ms	100
			P535	Sampler Factor	-	0
		ALARM	P540	PV Out of Limits	-	None
			P541	Current Output Saturated	-	None
			P542	Logging Memory Filling	-	None
			P543	Digital Input 1 Active	-	None
			P544	Maximum number of retries	-	None
			P545	Current Input Saturated	-	None
			P547	Rising level	-	None
		RELAY	P548	Relay operations	-	None
			P549	Relay runtime	-	None
			P550	Pump efficiency	-	None
			P551	No activity	-	None
		FAULT	P560	System Fault Alarm	-	Both
		FAULT	P561	Control Unit Temperature over Limits	-	None
		FAULT	P562	Transmitter Fault	-	Both
		DISPLAY	P570	Display Select 1 (upper)	-	P731-Time
		DISPLAY	P571	Display Select 2 (mid)	-	D800-PV
		DISPLAY	P572	Display Select 3 (lower)	-	Bargraph
		DISPLAY	P573	Decimal places	-	3
		DISPLAY	P575	Backlight On/Off	-	On
		LOGGING		Logging Wizard	-	0
			P590	Logging interval	min	0
			P591	Fast logging select mode	as P200	0
			P592	Do/Do not overwrite old data	-	On
			P593	Low Memory Alarm Threshold	%	0
		SYSTEM		Self Test	-	-
		TEST		Display Test	-	-
		TEST		4mA input adjust	-	-
		TEST		20mA input adjust	-	-
		TEST		4mA output adjust	-	-
		TEST		20mA output adjust	-	-
		TEST		Set Current	mA	0
		DEFAULTS		DEFAULTS	-	-
		COMMS		Comms Address	-	0
		COMMS		Interface Type	-	Log download
		COMMS		Baud Rate	-	9600
		COMMS		No. of Start Bits	-	1
		COMMS		No. of Data Bits	-	8
		COMMS		Parity of Data	-	Even
		COMMS		No. of Stop Bits	-	1

		SETTINGS		P730	Date	-	01/01/00
		SETTINGS		P731	Time	-	-
		SETTINGS		P734	Date format	-	dd/mm/vy
		SETTINGS		P735	Keypad Sound On/Off	-	On
		SETTINGS		P737	Language	-	English
		SETTINGS		P740	Personal Identification Code	-	0000
		>			Xmtr Wizard	-	0
		FIXED		D750	Model Code	-	MCU902WX-A
		FIXED		D751	Serial Number - Control Unit	-	000000
		FIXED		D752	Hardware Revision	-	8
		FIXED		D753	Software Version	-	12
		FIXED	HART	D760	Manufacturer's Code	-	Mobrey
		FIXED	HART	D761	Unique ID	-	000000
		FIXED	HART	D762	Universal Command Revision	-	5
		FIXED	HART	D763	Transmitter Spec. Command Rev.	-	1
		FIXED	HART	D764	Preamble Bytes	-	5
		FIXED	HART	D765	Flags	-	1
MONITOR	READINGS	ANSWERS		D800	Primary Variable	as P200	-
		ANSWERS		D801	Secondary Variable	as P201	-
		ANSWERS		D802	Tertiary Variable	as P202	-
		ANSWERS		D803	Fourth Variable	as P203	-
		ANSWERS		D804	Ullage	as P200	-
		ANSWERS		D805	% Current Output	%	-
		ANSWERS		D806	Current output	mA	-
		>		D809	Rate of Change	PV/min	-
		RELAY	RELAY OPERATIONS	D811	Relay 1 Operations	-	0
		RELAY	RELAY OPERATIONS	D812	Relay 2 Operations	-	0
		RELAY	RELAY OPERATIONS	D813	Relay 3 Operations	-	0
		RELAY	RELAY OPERATIONS	D814	Relay 4 Operations	-	0
		RELAY	RELAY OPERATIONS	D815	Relay 5 Operations	-	0
		RELAY	>	D820	Relay Status	-	-
		RELAY	RELAY RUN TIME	D821	Relay 1 Run-Time	hh:mm	-
		RELAY	RELAY RUN TIME	D822	Relay 2 Run-Time	hh:mm	-
		RELAY	RELAY RUN TIME	D823	Relay 3 Run-Time	hh:mm	-
		RELAY	RELAY RUN TIME	D824	Relay 4 Run-Time	hh:mm	-
		RELAY	RELAY RUN TIME	D825	Relay 5 Run-Time	hh:mm	-
		>		D828	Totaliser 1 Value	P531	-
		>		D829	Totaliser 2 Value	P533	-
		>		D830	Alarm report	-	None
		>		D831	Fault report	-	None
	DIAGNOSTICS			D835	Digital input status	-	-
				D840	Current input	mA	-
				D842	Current input %	%	-
				D844	Temperature of Control Unit	°C	-
				D845	Time to next Pump Down	hh:mm	-
				D846	Logging Memory Free	%	-
				D848	Date of Last Change	dmy	--/--
				D849	Date of 1st Power-On	dmy	--/--
		CHANNELS		D851	Channel 1 output	P201	-
				D852	Channel 2 output	P202	-
		PUMP EFFICIENCY		D861	Pump efficiency RL1	%	-
				D862	Pump efficiency RL2	%	-
				D863	Pump efficiency RL3	%	-
				D864	Pump efficiency RL4	%	-
DIRECT	Pxxx				-	-	-
	Dxxx				-	-	-

A2.3.7.3 Menu structure and parameter list for the MCU90F

Function Menu Option	Sub-menu Level 1	Sub-menu Level 2	Sub-menu Level 3	Par No.	Parameter Name				
Cancel Password					Cancel Password				
Go Offline ?					Go Online/Offline ?				
SETUP	INPUT CHANNEL			P111	Channel 1 Input Source				
				P321	Current Input 1 Damping				
				P112	Channel 1 Input Offset				
				P113	Channel 1 Profile				
				P114	Channel 1 Input Scale Factor				
				P115	Channel 1 Non-Linear Data				
				P116	Channel 1 Post Scale NLP				
				P117	Channel 1 Low Cut-off				
		DUTY(Mode)				Flow Wizard			
			PV CALCULATION			P200	PV Units		
						P201	SV Units		
						P202	TV Units		
						P203	FV Units		
			PV DAMPING			P210	Output PV Damping		
						P240	Description		
						P241	Message		
						P242	Tag Number - Control Unit		
			CUSTOM			P250	Start On		
						P251	Stop On		
						P252	Stop If		
						P253	Start Time		
						P254	Interval		
						P255	Start Time #2		
						P256	Interval #2		
			OVERRIDES			P257	Max Retries		
					P275	Energy Saving Start Time			
		DIGITAL INPUT	DIGITAL INPUT 1			P276	Energy Saving Relay Select		
						P340	Digital Input 1 Action		
						P341	Digital Input 1 Delay		
				DIGITAL INPUT 2			P342	Digital Input 1 On State	
						P345	Digital Input 2 Action		
						P346	Digital Input 2 Delay		
		OUTPUT	CURRENT OUTPUT			P347	Digital Input 2 On State		
							P400	Lower range value	
							P401	Upper range value	
				RELAY			P402	Alarm action	
								Reset Relay Parameters	
					RELAY 1			P410	Relay 1 Mode
								P411	Relay 1 PV ON Point
								P412	Relay 1 PV OFF Point
								P413	Relay 1 Minimum ON Time
								P414	Relay 1 Maximum ON Time
					RELAY 2			P415	Relay 1 Minimum OFF Time
								P420	Relay 2 Mode
								P421	Relay 2 PV ON Point
								P422	Relay 2 PV OFF Point
								P423	Relay 2 Minimum ON Time
					RELAY 3			P424	Relay 2 Maximum ON Time
								P425	Relay 2 Minimum OFF Time
								P430	Relay 3 Mode
								P431	Relay 3 PV ON Point
								P432	Relay 3 PV OFF Point
					RELAY 4			P433	Relay 3 Minimum ON Time
								P434	Relay 3 Maximum ON Time
								P435	Relay 3 Minimum OFF Time
							P440	Relay 4 Mode	
							P441	Relay 4 PV ON Point	
			RELAY 5				P442	Relay 4 PV OFF Point	
							P443	Relay 4 Minimum ON Time	
						P444	Relay 4 Maximum ON Time		
						P445	Relay 4 Minimum OFF Time		
		ALARM					P450	Relay 5 Mode	
					P451	Relay 5 PV ON Point			
					P452	Relay 5 PV OFF Point			
					P453	Relay 5 Minimum ON Time			
					P454	Relay 5 Maximum ON Time			
					P455	Relay 5 Minimum OFF Time			
	TOTALISER				P490	Rising level alarm delay			
					P491	Relay operations			
					P492	Relay operations relay select			
					P493	Relay runtime			
					P494	Relay runtime relay select			
					P497	No activity delay			
					P498	No activity relay			
						Totaliser Wizard			
					P530	Totaliser 1 Factor			
					P531	Totaliser 1 Units			
				P532	Totaliser 2 Factor				
				P533	Totaliser 2 Units				
				P536	Totaliser 2 Source				
				P537	Totaliser 2 Decimal Places				
				P534	Totaliser Pulse width				
				P535	Sampler Factor				

SETUP (contd)	OUTPUT (contd)	ALARM		P540	PV Out of Limits		
				P541	Current Output Saturated		
				P542	Logging Memory Filling		
				P543	Digital Input 1 Active		
				P544	Maximum number of retries		
				P545	Current Input Saturated		
				P547	Rising level		
				RELAY		P548	Relay operations
						P549	Relay runtime
						P551	No activity
				FAULT		P560	System Fault Alarm
						P561	Control Unit Temp over Limits
						P562	Transmitter Fault
				DISPLAY		P570	Display Select 1 (upper)
						P571	Display Select 2 (mid)
						P572	Display Select 3 (lower)
						P573	Decimal places
						P575	Backlight On/Off
				LOGGING		P590	Logging interval
						P591	Fast logging select mode
						P592	Do/Do not overwrite old data
						P593	Low Memory Alarm Threshold
		SYSTEM		TEST	AUTO-CYCLE		Self Test
					DISPLAY		Display Test
					CURRENT INPUT		4mA input adjust
							20mA input adjust
					CURRENT OUTPUT	P700	4mA output adjust
						P701	20mA output adjust
						P702	Set Current
		DEFAULTS			Load Defaults		
		COMMS		P710	Comms Address		
				P711	Interface Type		
				P712	Baud Rate		
				P713	No. of Start Bits		
				P714	No. of Data Bits		
				P715	Parity of Data		
				P716	No. of Stop Bits		
		SETTINGS		P730	Date		
				P731	Time		
				P734	Date format		
				P735	Keypad Sound On/Off		
				P737	Language		
				P740	Personal Identification Code 1		
					Xmtr Wizard		
		FIXED		D750	Model Code		
				D751	Serial Number - Control Unit		
				D752	Hardware Revision		
				D753	Software Version		
			HART	D760	Manufacturer's Code		
				D761	Unique ID		
				D762	Universal Command Revision		
				D763	Transmitter Specific Cmd Rev		
				D764	Preamble Bytes		
				D765	Flags		
MONITOR	READINGS	ANSWERS		D800	Primary Variable		
				D801	Secondary Variable		
				D802	Tertiary Variable		
				D803	Fourth Variable		
				D804	Ullage		
				D805	% Current Output		
				D806	Current output		
				D809	Rate of Change		
				RELAY		D811	Relay 1 Operations
						D812	Relay 2 Operations
						D813	Relay 3 Operations
						D814	Relay 4 Operations
						D815	Relay 5 Operations
						D820	Relay Status
						D821	Relay 1 Run-Time
						D822	Relay 2 Run-Time
						D823	Relay 3 Run-Time
						D824	Relay 4 Run-Time
						D825	Relay 5 Run-Time
						D828	Totaliser Value
						D830	Alarm report
						D831	Fault report
				DIAGNOSTICS		D835	Digital input status
						D840	Current input
						D842	Current input %
						D844	Temperature of Control Unit
						D846	Logging Memory Free
						D848	Date of Last Change
						D849	Date of 1st Power-On
		CHANNELS		D851	Channel 1 output		
DIRECT	Pxxx				-		
	Dxxx				-		

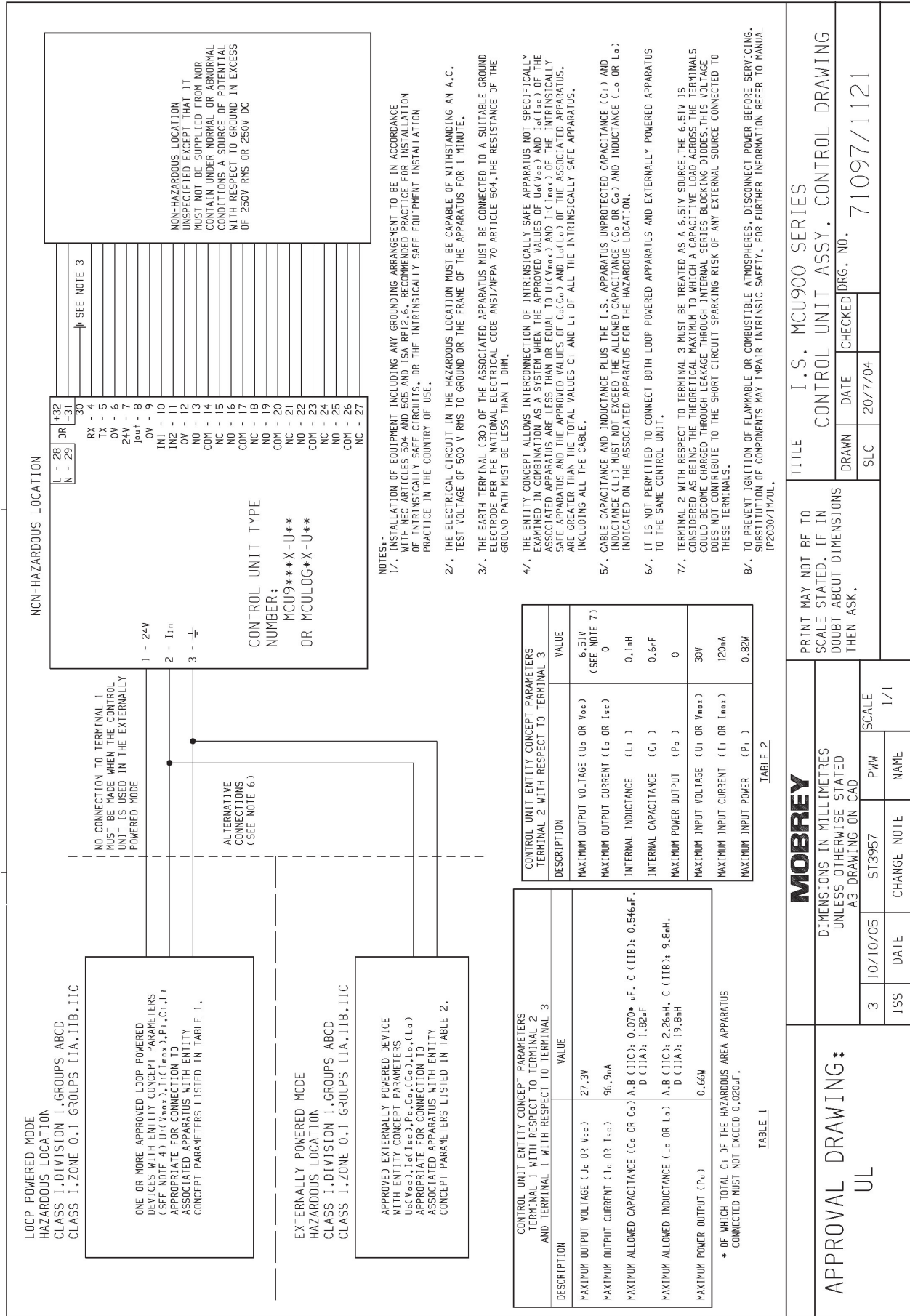



**LISTED
PROCESS
CONTROL EQUIPMENT
PROCESS
CONTROL EQUIPMENT
ASSOCIATED APPARATUS**



The Emerson logo is a trade mark and service mark of Emerson Electric Co.
Rosemount is a registered trademark of Rosemount Inc.
Mobrey is a registered trademark of Mobrey Ltd.
All other marks are the property of their respective owners.
We reserve the right to modify or improve the designs or specifications of product and services at any time without notice.

International:

Emerson Process Management

Mobrey Measurement

158 Edinburgh Avenue,
Slough, Berks, SL1 4UE, UK

T +44 1753 756600

F +44 1753 823589

www.mobrey.com

Americas:

Emerson Process Management

Rosemount Inc.

8200 Market Boulevard
Chanhassen, MN USA 55317

T (US) (800) 999-9307

T (International) (952) 906-8888

F (International) (952) 949-7001

