

# Spare PCBs for the SQUING 2

Vibrating fork point level switch



## CAUTION:



**REFER TO THIS MANUAL. USE IN CONJUNCTION WITH MANUAL IP2025**



**RISK OF ELECTRICAL SHOCK**



**THE EXTERNAL SURFACE MAY BE HOT. CARE MUST BE TAKEN TO AVOID POSSIBLE BURNS.**

## IMPORTANT SAFETY NOTICE:

Protection afforded by compliance to EN61010-1 (2001) may be impaired if the equipment is not used as specified. SQUING 2 is a liquid level switch.

It must be installed, connected, commissioned, operated and maintained by suitably qualified personnel only, observing any national and local requirements that may apply.

# Replacement and Calibration of cassette

This is a list of actions required to enable calibration to occur. Please make sure you understand them prior to starting. **Calibration sequence steps 8 to 18 are time dependant and must be carried out within the noted times.** The time dependency and switching sequence is to stop an accidental calibration occurring.

If this replacement is taking place in a (Potentially Explosive Atmosphere) Hazardous Area, a suitably qualified person must carry it out. All work in hazardous areas must be carried out in accordance to local code of practice. For general hazardous area requirements for this equipment, refer to IP2025/SI, IP2025/SI-EXD and IP2025/SI-FM-EXD safety instructions.

This calibration routine does take a bit of practice; do not be surprised if the unit does not calibrate at the first few attempts.

## Replacement sequence:

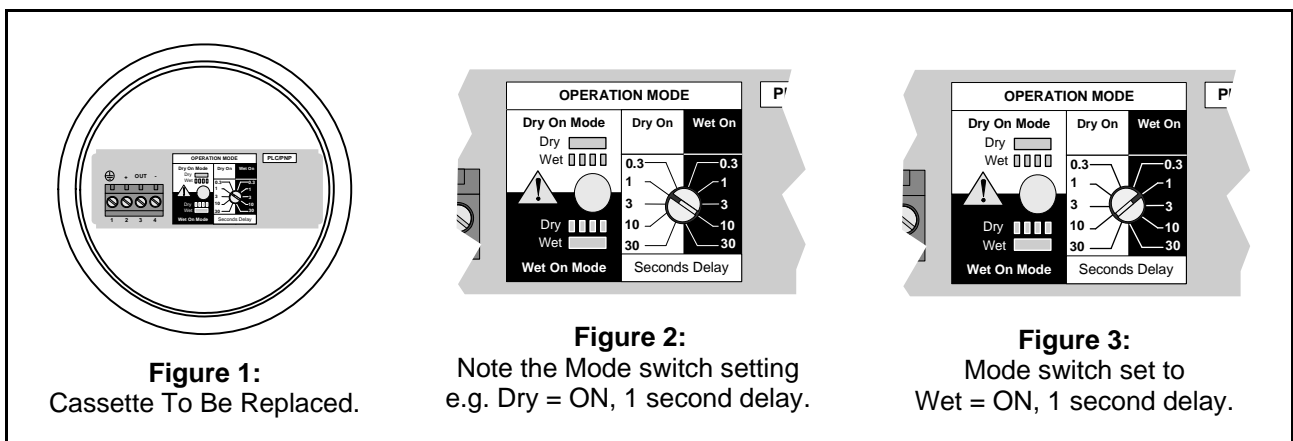
On I.S. units, it is recommended that replacement and calibration be performed in a safe (non-hazardous) area.

### NOTE:

- (1) I.S. cassettes can only be replaced with I.S. cassettes.
- (2) Non-I.S. cassette types can be interchanged with other non-I.S. cassettes, but the new label must be fitted and the original part number transferred to the new label.
- (3) Before starting the replacement and calibration procedure, ensure that any controlled process will not be adversely affected.

### Steps

1. Isolate and disconnect the power to the SQUING 2. Insulate ends of the wires.  
**Note:** On relay units, there may be more than one power source.
2. Remove the screwed-on lid and disconnect the wires, noting connections (Figure 1). Also, note the exact **Mode switch** position (Figure 2) on the cassette that is to be replaced.
3. Remove and retain the two fixing screws from the base of the cassette and unplug the cassette.
4. Plug in the replacement cassette, refit the screws, reconnect the wires and set the Mode switch to **Wet = ON** with a **one second delay** (Figure 3).
5. Reconnect the power to the unit. (Reverse step 1).



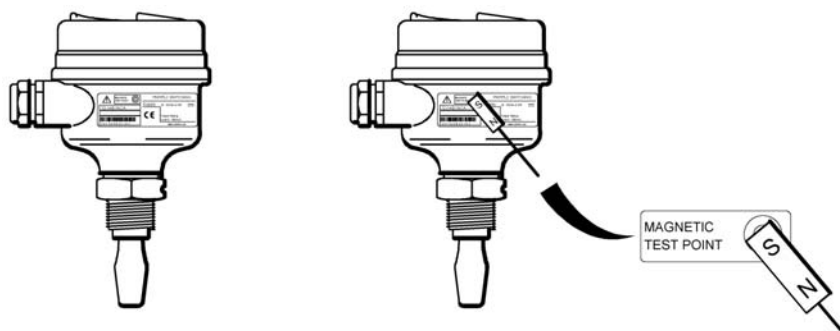
### Note:

Switching time delay:	0.3, 1, 3, 10 or 30 seconds (mode switch selection)	
Status Indication LED:	On continuous:	Output ON
	One flash per second:	Output OFF
	One flash every 4 seconds:	Load Fault (Current too high, short circuit or load omitted)

## Calibration sequence:

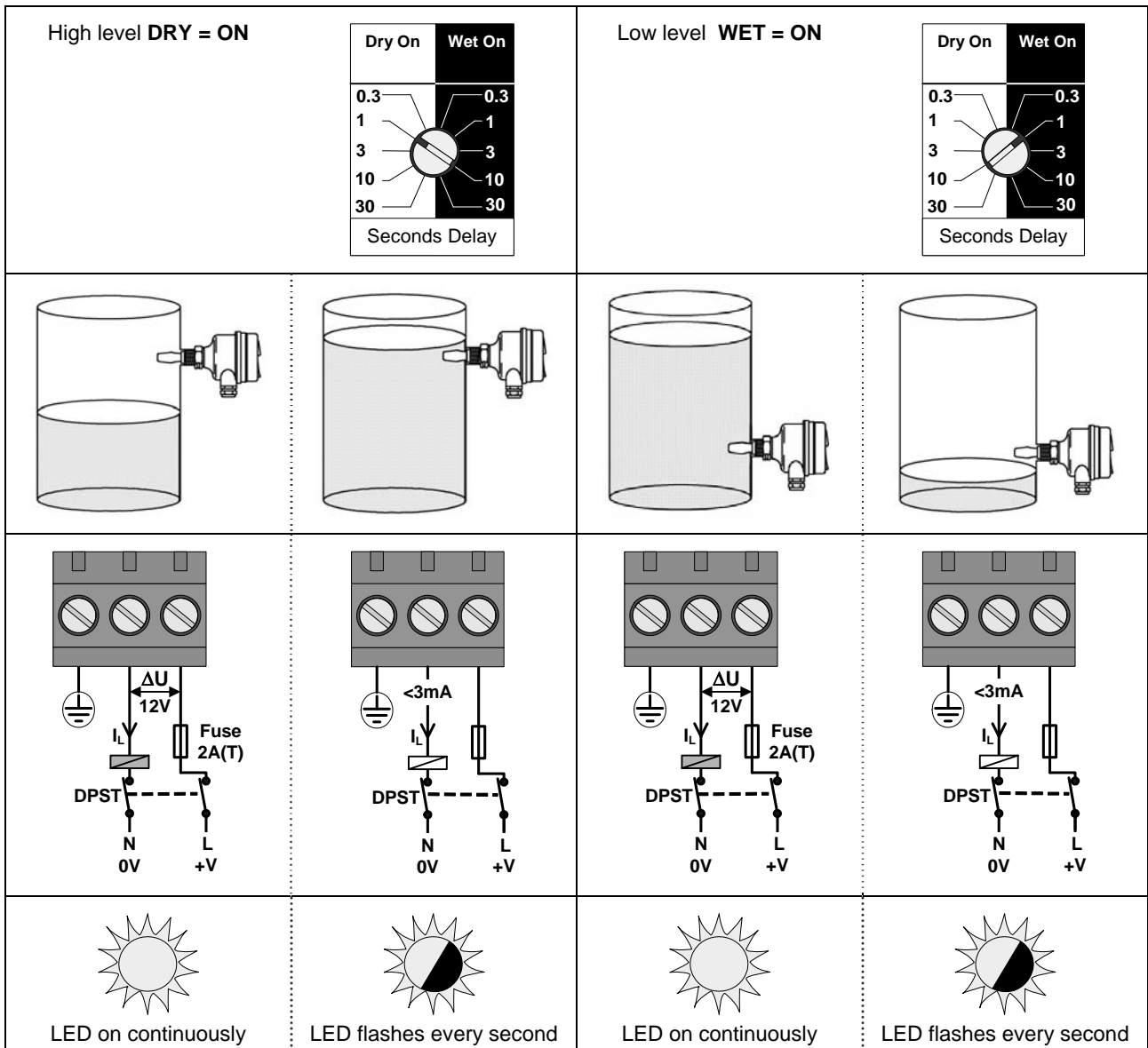
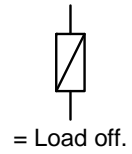
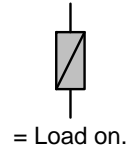
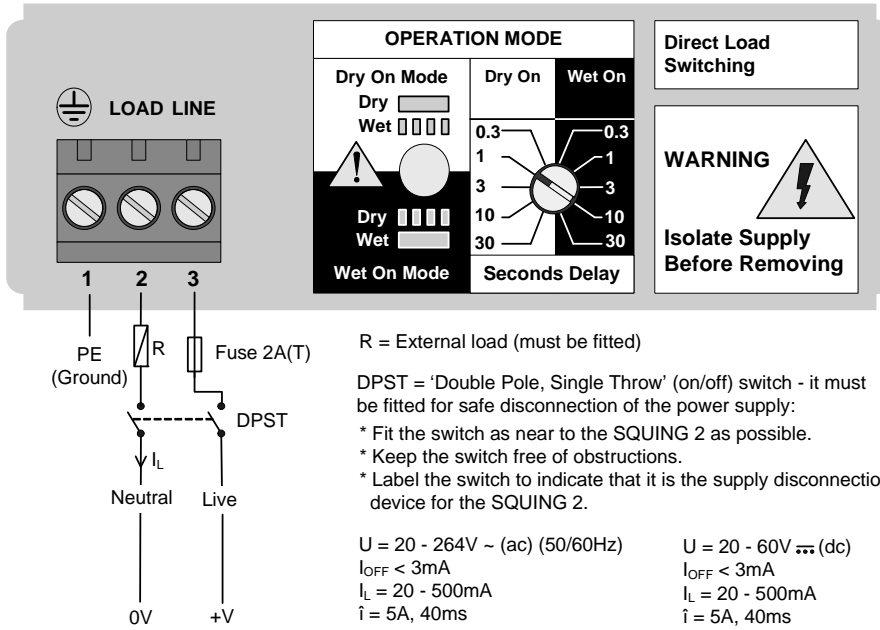
### Steps

6. **Ensure** that the sensor forks are **dry**.
7. Check that the LED is flashing at one flash per second. If it is on continuously, proceed to step 13.
8. Apply magnet to test point. With the housing conduit nearest to you, the test point can be found halfway down the housing on the right hand side in line with the PCB cassette. On the plastic housings, a target on the external housing label (side) indicates this. (Figure 4).
9. After a one second delay, the LED will light continuously.
10. Within three seconds rotate the Mode switch two steps clockwise.
11. After a two second delay, the LED will go out.
12. Within three seconds, rotate the Mode switch two steps anti-clockwise. Proceed to step 18.
13. Apply magnet to test point, indicated by a target on external label (Figure 4).
14. After a one second delay, the LED will flash at one flash per second.
15. Within three seconds, rotate the Mode switch two steps clockwise.
16. After a two second delay, the LED will go out (stop flashing).
17. Within three seconds, rotate the Mode switch two steps anti-clockwise.
18. After a two second delay, the LED should flash twice per second.
19. If the LED is flashing twice per second, the calibration has occurred correctly. Remove the magnet. After a one second delay, the unit will return to normal operation. Proceed to step 22.
20. If the LED is flashing once per second or it is on continuously, the calibration has failed. If this occurs, remove the magnet, wait ten seconds and then repeat from step 7 onwards.
21. If the LED stays off after the two second delay of step 18, the sensor is not working correctly. Check that the sensor forks are clean and dry. Also, check that there is nothing jammed in or touching the sensor. If no fault is found with the sensor, the entire unit should be returned for repair.
22. Set the Mode switch to the setting noted in step 1. Wait five seconds for the new setting to be acted upon.
23. Replace the lid and check the system works.

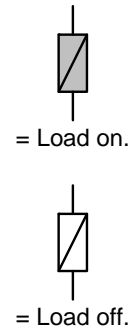
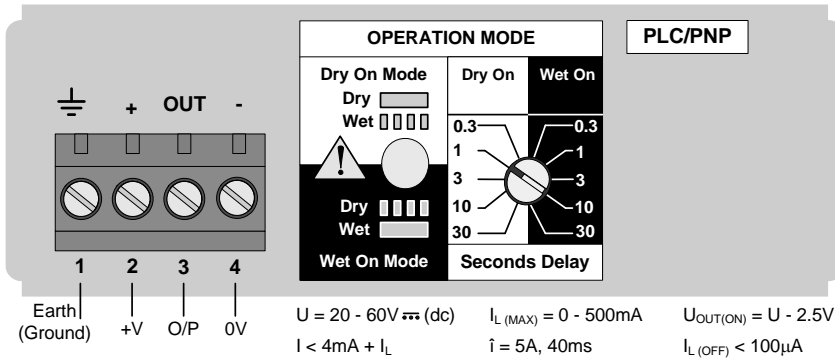


**Figure 4:** Magnetic test point

# Direct load switching (2 Wire) (Red)

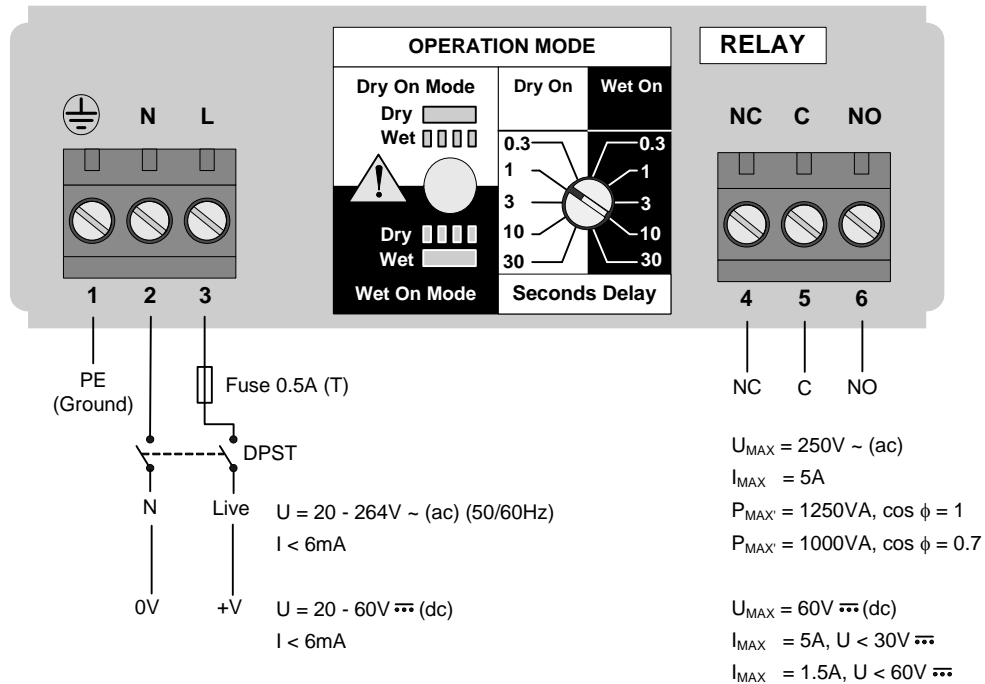


# PNP output for load switching and direct PLC switching (Yellow)



	<p><b>High level DRY = ON</b></p>	<p><b>Low level WET = ON</b></p>	
<b>PLC +I/P</b>	<p><math>\Delta U &lt; 3\text{V}</math></p> <p><math>I_L</math></p>	<p><math>&lt; 100\mu\text{A}</math></p> <p><math>I_L</math></p>	<p><math>\Delta U &lt; 3\text{V}</math></p> <p><math>I_L</math></p>
<b>PNP dc</b>	<p>Fuse 2A(T)</p> <p><math>\Delta U &lt; 3\text{V}</math></p> <p><math>I_L</math></p>	<p>Fuse 2A(T)</p> <p>R</p> <p><math>&lt; 100\mu\text{A}</math></p> <p><math>I_L</math></p>	<p>Fuse 2A(T)</p> <p><math>\Delta U &lt; 3\text{V}</math></p> <p>R</p> <p><math>I_L</math></p>
	LED on continuously	LED flashes every second	LED flashes every second

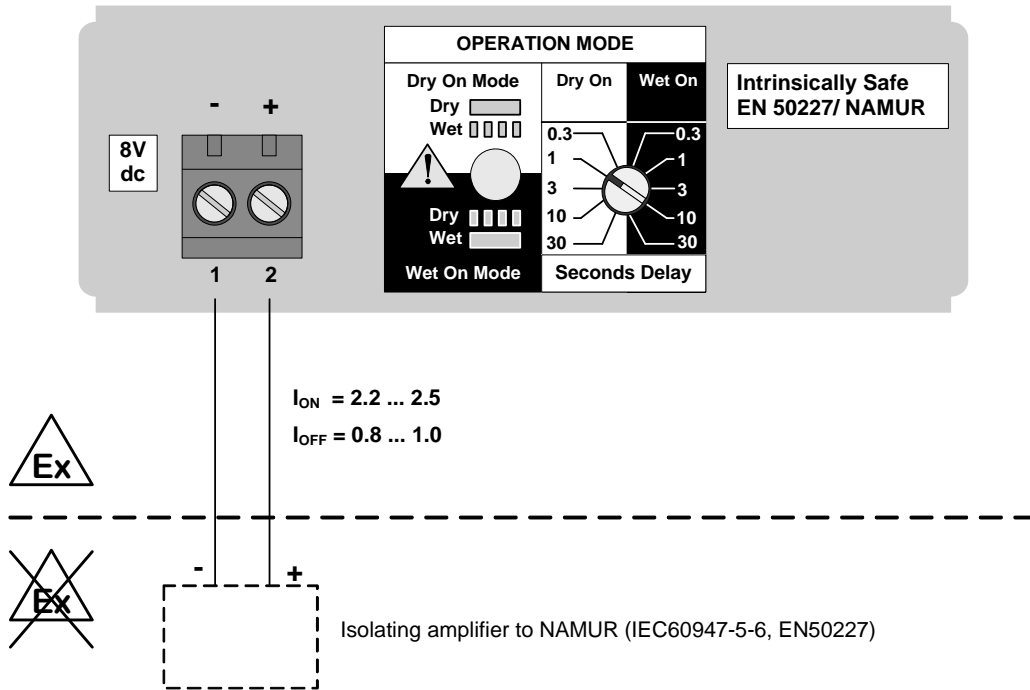
# Relay output, SPCO, (Green)



DPST = 'Double Pole, Single Throw' (on/off) switch - it must be fitted for safe disconnection of the power supply. Fit the switch as near to the SQUING 2 as possible. Keep the switch free of obstructions. Label the switch to indicate that it is a supply disconnection device for the SQUING 2.

High level <b>DRY = ON</b>		Low level <b>WET = ON</b>	
LED on continuously	LED flashes every second	LED on continuously	LED flashes every second

# Intrinsically Safe NAMUR (Blue)



High level DRY = ON		Low level WET = ON	
LED on continuously	LED flashes every second	LED on continuously	LED flashes every second

## Troubleshooting

<b>Fault</b>	<b>Cause/Indication</b>	<b>Reason / Solution</b>
Does not switch.	No LED, no power.	Check the power supply; (check load on direct load switching electronics model).
	LED 3 flashes per second.	Internal failure. Return to supplier.
	LED 1 flash every 2 seconds.	Not calibrated. Repeat calibration procedure.
	LED 1 flash every 4 seconds.	Load fault; load current too high, load short circuit; check installation.
	5 second delay on changing mode/delay.	Wait 5 seconds.

**PAGE LEFT BLANK INTENTIONALLY**

**PAGE LEFT BLANK INTENTIONALLY**

**PAGE LEFT BLANK INTENTIONALLY**

# SQUING 2

## Installation and Instruction Booklet

IP2025/PCB

April 2006, Rev. AA

---

*The Emerson logo is a trade mark and service mark of Emerson Electric Co.  
Rosemount is a registered trademark of Rosemount Inc.  
Mobrey is a registered trademark of Mobrey Ltd.  
All other marks are the property of their respective owners.*



*We reserve the right to modify or improve the designs or specifications of product and services at any time without notice.*

*International:*

**Emerson Process Management  
Mobrey Measurement Division**

158 Edinburgh Avenue, Slough,  
Berks, SL1 4UE, UK  
Tel: +44 (0)1753 756600  
Fax: +44 (0)1753 823589  
[www.mobrey.com](http://www.mobrey.com)

*Americas:*

**Emerson Process Management**

8200 Market Boulevard  
Chanhassen, MN USA 55317  
Tel: (US) (800) 999-9307  
Tel: (International) (952) 906-8888  
Fax: (International) (952) 949-7001  
[www.rosemount.com](http://www.rosemount.com)

