

Mobrey

Vertical Controls



Series B



Series X



Series D

For instructions specific to ATEX approved flameproof models in hazardous area installations, refer to accompanying leaflet IP152/SI Exd

Level

Mobrey vertical magnetic level controls

Principle of Operation

Switching is achieved with the Mobrey Measurement “three-magnet” system, giving snap-action “latch-on” switching.

Vertical movement of the primary magnet A in a glandless pressure tube simultaneously actuates magnets B & C to switch the contacts. The “three-magnet” system enables the primary magnet to pass on and actuate switch mechanisms at other levels. Switch mechanisms already actuated can not re-set until the return of the primary magnet actuates the magnet system once again.

The primary magnet is moved vertically in the pressure tube by a float or displacer mechanism which rises and falls with the liquid level.

Identifying your control

This manual covers the three series of controls: B, X and D as shown opposite. Your control has a part number stamped on the nameplate, an example of which is shown below. From this number you can identify your control and turn to the relevant pages in this manual. As switch mechanisms are common to all three series, electrical characteristics are given on page 4.

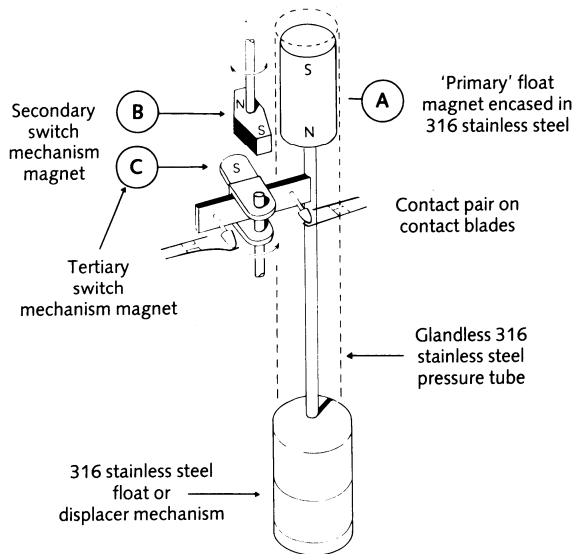

Diagrammatic detail of three magnet system



Series B pages 5 & 6



Series X pages 5 & 6



Series D pages 7 & 8

XC 13F S7A 1 D8/112

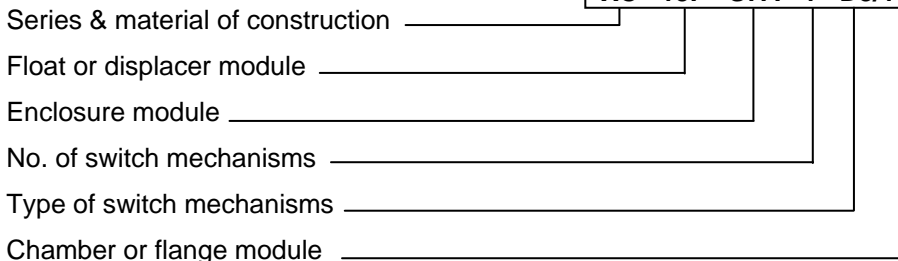

Controls manufactured to customer's requirements outside of our standard range will be numbered 707★★/★★★/★ and may be identified according to the pictures above.

Displacer operated controls are covered in Installation Instruction booklet IP153.

Level

Electrical characteristics

4 Contact Type : D4, X4, P4, H4

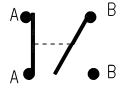

2x independent SPST
AA make on rise : BB make on fall

8 Contact Type : D8, X8, P8, H8

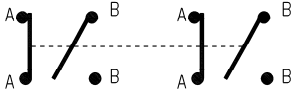

Double pole double throw
(4x independent SPST)
AA make on rise : BB make on fall

Note: For DPDT operation, installer must common any one pair of A and B wires in the terminal block for each of the two ends of the switch mechanism.

Wiring Examples

Single-switch Control

As high level alarm A ● Alarm ON
A ●
B ●
B ●

As low level alarm A ●
A ●
B ● Alarm ON
B ●

**Two-Switch Control
Combined Pump Control
And Low Level Alarm**

Pump Control Switch A ● Pump ON
A ●
B ●
B ●

LLA Switch A ●
A ●
B ● Alarm ON
B ●

**Two-switch Control
High and Low Level Alarm**

HLA Switch A ● Alarm ON
A ●
B ●
B ●

LLA Switch A ●
A ●
B ● Alarm ON
B ●

Each switch mechanism has flying leads which are factory wired to ceramic terminal blocks fixed in the switch enclosure.

Electrical rating

Type	Temp wetside °C	Low Temp use	AC max. values			AC max. values			
			VA	Volts	Amps	Watts	Volts	Res amps	Ind amps
D4, D8	400	Amp.	2000	440	5	50	250	5	0.5
X4, X8	250	Amb.	2000	440	10	50	250	10	0.5
P4, P8	400	Amb.	6	250	0.25	3.6	250	0.25	0.1
H4, H8	250	-100°C	2000	400	5	50	250	5	0.5
Power factor 0.4 mm						Time constant 40ms max.			

Warning

Gold plating on the contacts of the P4 and P8 switch mechanisms may be permanently damaged if the mechanisms are used to switch circuits with values greater than those shown above.

Important wiring notes

- To minimize the electrical shock hazard, **before energizing** it is essential that the equipment is connected to a protective ground using the terminals supplied.
- Switches must not be used for the direct starting of motors. Contacts should be wired in series with the operating coils of relays, contactor starters or solenoid valves, and fused separately.
- The temperature of the switch enclosure may at times approach the temperature of the process and suitable heat resisting cables should therefore be used, together with appropriate cable glands.
- A sufficient length of flexible cable should be fitted to allow easy removal of the switch head and displacer assembly at any time.

Flameproof models

- Cable entry must be fitted with a flameproof cable entry device, with or without thread adaptor, and should be used in accordance with a local Code of Practice subject to agreement by the local Inspecting Authority.
- U.L. Approved Applications: Use copper conductors 60°/75°C: 140°/167°F ONLY. Torque terminals to 6kg/cm: 7lb/in.

7. Ensure the cover locking safety grub screw is replaced and tightened before energizing.

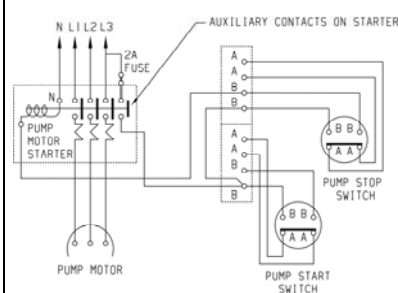

Two switch pump control circuit using auxiliary contacts on starter.
Note diagram shows starter fitted with 250V coil for 3-phase 3-wire supply connect coil terminal N to line 1 and fit 440V coil.

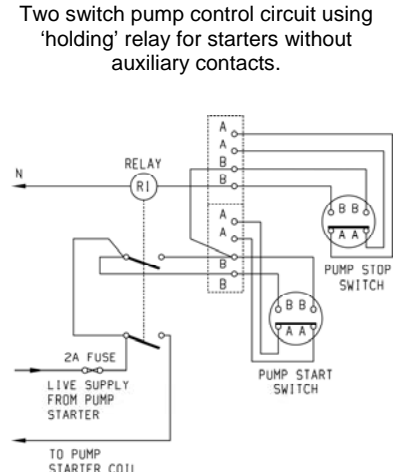

Two switch pump control circuit using 'holding' relay for starters without auxiliary contacts.

P4, P8, H4, H8 Switch Mechanisms - Simple Apparatus

These Switch Mechanisms in a standard switch housing are classified as "Simple Apparatus" when used in Intrinsically Safe circuits. They comply with the requirements of EN60079-0, General Requirements and EN60079-11, clause 5.7 'Simple Apparatus' and are not considered as a potential source of ignition for an explosive atmosphere.

They do not fulfill the definition of equipment in Article 1 (3) of Directive 94/9/EC (Equipment Explosive Atmospheres (ATEX)) and are therefore outside the scope of this Directive and do not have a Declaration of Conformity or CE mark related to this Directive.

When used as "Simple apparatus" within a hazardous atmosphere the following should be noted:

1. The product should be installed by suitably trained personnel, in accordance with the applicable code of practice.
2. As the product has no source of internal heating, the temperature classification is dependent on the ambient air temperature and the temperature of the process vessel to which it is attached.
3. Materials of construction: Refer to product catalogue or customer drawing for actual material of level switch concerned.

Housing and Cover: Carbon Steel, or Stainless Steel 316 type, or Aluminium Alloy LM25 or LM24 or B85 grd 360, or Cast Iron grd 250, or Gunmetal LG2

Pressure Tube & Union: Stainless Steel types 316, 321 or 304, or Carbon Steel 220M07, or Alloy NA18, or Alloy C-276 (UNS N10276) or Alloy 625 UNS N06625, or Alloy 825 UNS N08825

If the equipment is likely to come into contact with aggressive substances, it is the responsibility of the user to take suitable precautions that prevent it from being adversely affected, thus ensuring that the type of protection is not compromised.

Aggressive substances: e.g. acidic liquids or gases that may attack metals or solvents that may affect polymeric materials.

Suitable precautions: e.g. regular checks as part of routine inspections or establishing from the material's data sheet that it is resistant to specific chemicals.

Note: The metallic alloy used for the enclosure material may be at the accessible surface of this equipment; in the event of rare accidents, ignition sources due to impact and friction sparks could occur. This shall be considered when the switch is being installed in locations that specifically require group II, category 1G equipment.

4. It is the responsibility of the user to ensure:
 - a. The joint requirements between the switch housing and vessel are compatible with the process media.
 - b. The joint tightness is correct for the joint material used.
 - c. That suitable temperature rated cable is used. **Note:** The cable entry temperature may exceed 70°C
 - d. The float is protected from impact or friction, or static electrical build-up from fast flowing non-conductive fluids, that could generate an ignition source.

Level

Series B & X Installation Instructions

When installing, using or maintaining external chambers supplied compliant with the Pressure Equipment Directive, refer also to the Safety Information (leaflet No. IP152/SI) supplied with the product for further details.

Installation shall be carried out by suitably trained personnel in accordance with applicable codes of practice.

1. Remove all sealing tapes, tie strings and packing from the control prior to installation.
2. Mount the control on the inlet and outlet connections, ensuring that the central line axis of the control is vertical to the eye. Use suitable process connection gaskets and seals as dictated by the application.
3. Check bolt torques on process and switch head flange bolts are in accordance with torques shown on page 12.

Note

- i) A 50mm weld bead or label on the chamber indicates the highest operating level of the control. Switch point adjustment of 94mm is provided on multi-switch models only and is measured down from this level.
- ii) Allow at least 200mm above the control for removal of cover.
3. Remove switch head cover to reveal terminal block(s) to which electrical connections are to be made.
 Flameproof models: Locate and slacken off M5 socket head safety grub screw on side of cover adjacent to base joint. Place a bar across the top of the cover, locating in the castellations. The cover can now be unscrewed from the base using the bar as a lever.
 Weatherproof models: The cover can be removed by unscrewing the single hexagon nut at the crown of the cover.
4. Connect electrical wiring via the conduit entries using a suitable cable gland. Note that the base of the enclosure is rotatable on the pressure tube to allow the most convenient orientation of the conduit entry.

Refer to wiring notes on page 4.

On models with flameproof enclosures type ★7★ the switch mechanism may be raised on the pressure tube to ease access to the terminal block. Ensure that the switch mechanism is re-positioned to its lowest position (i.e. sitting on the limit tube around the pressure tube) after wiring.

5. Switch point adjustments may now be made if necessary. See below.
6. The lugs of the tab washer directly underneath the base must now be bent over to locate on the most appropriate flats of the hexagon union. This prevents further rotation of the switch head, and is particularly important as it will prevent rotation when the cover is removed or re-fitted.
7. Check the cover seals are present and in good condition, and then replace the cover.
 - (i) **Before energizing** flameproof / Type ★7★ models, ensure the cover locking safety grub screw is replaced and tightened. Do not energize if the cover locking safety grub screw is missing.
 - (ii) **Before energizing** weatherproof / Type ★4★ models, ensure the weatherproofing fibre sealing washer at the crown nut is in place.

Switching Point Adjustment

Each switch mechanism is mounted on a bracket, which is secured on the pressure tube by a locking screw and lock nut. These can be loosened, allowing the bracket to be adjusted up or down as required. Always ensure that the small pressure plate between the locking screw and the pressure tube is in place before re-tightening the locking screw nut.

Important note: Switches cannot be adjusted outside of the range set by the stops on the pressure tube. Displacer operated control type ★★17D are single switch models with the switching point factory set.

There is *no* site adjustment.

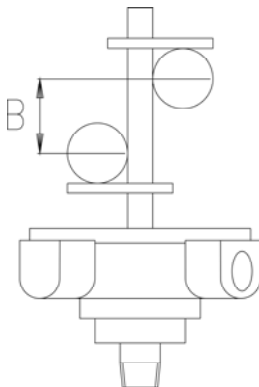

Enclosure Type		Switch Mechanism Type		
		D4, P4, X4	H4	D8, P8, X8, H8
Max. No. Switches	R7A	1	1	1
Sw. Adjustment 'B' mm	R7I	7	7	7
Max. Wet switching differential	R4N	Type 11F, 12F, 13F, 14F : 20mm Type 17D : See table above (D-C)		
Max. No. Switches	S7A	4	4	2
Sw. Adjustment 'B' mm	S7I	94	94	94
Min. Sw Crs 'B' mm	S7I	94	94	94
Max. Sw Crs 'B' mm	S4N	7	0	56
Max. Wet switching differential		Type 11F, 12F, 13F, 14F : 120mm		

Installation, operation & maintenance instructions

IP152, Rev AD

April 2012

Level

Operating Level Data

Models Type No. B★11F, B★12F, B★13F, B★14F, B★17D, X★11F, X★12F, X★13F, X★14F, X★17D

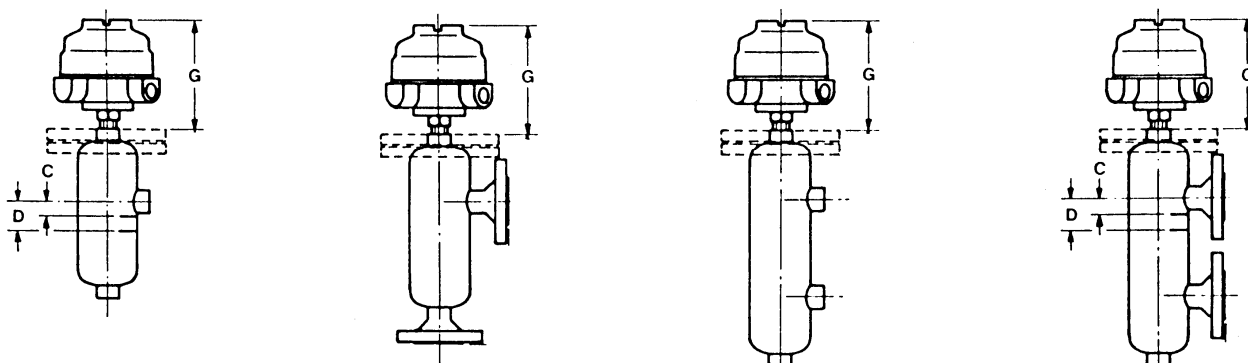

C = Highest Operating Liquid Level
D (Single Switch) = Reset Level

D (Multi-Switch) = Lowest Operating Liquid Level
D-C = Wet Switching Differential (Max)

Operating Levels : Single switch models				
Min Operating S.G.	11F : 0.80	12F : 0.75	13F : 0.65	14F : 0.54
Dimension C	50	50	50	50
Dimension D	70	70	70	70

Operating Levels : Multi-switch models				
Min Operating S.G.	11F : 0.80	12F : 0.75	13F : 0.65	14F : 0.54
Dimension C	50	50	50	50
Dimension D	170	170	170	170

Operating Levels : Type 17D float in any chamber : Single switch only									
Min Operating S.G.	0.4	0.5	0.6	0.7	0.8	0.9	1.0	1.1	1.2
Dimension C	65	73	82	91	100	109	118	127	136
Dimension D	118	122	127	132	137	141	147	152	156

Dimensional Data : Enclosures					
Type	Duty	Height G	Conduit Thread	Switch Adjustment	Weatherproof Rating
R7A, R71	Flameproof	190	1" NPT	10	IP66 to IEC 60529 (NEMA 4)
S7A, S71		300		94	
R4N	Weatherproof	170	1" NPT	10	IP66 to IEC 60529 (NEMA 4)
S4N		275		94	
L4N		375		194	

Enclosures for use with 8 contact switch mechanisms have both conduit entries threaded, whilst those for use with 4 contact switch mechanisms have only one entry. See Note 4, page 4.

Level

Series D Installation Instructions

Installation shall be carried out by suitably trained personnel in accordance with applicable codes of practice.

- Remove all sealing tapes, tie strings and protective packings from the control prior to installation. If float rod length needs adjusting to allow a higher operating level, refer to adjustment notes on page 8.
Note: Careful handling is required at all times to ensure float and float rod are not damaged or bent.
If a control is fitted with a longer than standard rod (i.e. dimension H is greater than that shown in the adjoining table) or the liquid is subject to excessive turbulence or agitation, then a stilling tube should be fitted.
- If control has been ordered without a mounting flange, the float unit must be removed from the control before the switch head can be mounted on the vessel via the 1"NPT threaded boss provided. This is achieved by locating the Stop Assembly at the base of the 1"NPT threaded boss and easing the spring clip, allowing the entire float assembly to be removed.
- Mount the switch head on the vessel using the flange (if provided) or the 1"NPT threaded boss ensuring that the centre line axis is vertical to the eye. If the threaded boss is used, ensure a pressure tight seal is formed between it and the vessel. Use only the hexagonal boss to tighten the 1"NPT thread into the mounting boss or flange. Torque flange bolts in accordance with torques shown on page 12.
- Ensure that magnet is free from swarf and debris before re-fitting to switch head. Locate the two ends of the spring clip in the two cross holes in the base of the pressure tube ensuring that float assembly is free to move vertically and is securely retained by the Stop Assembly.
- Remove switch head cover to reveal terminal block(s) to which electrical connections are to be made:-
Flameproof models: Locate and slacken off M5 socket head safety grub screw on side of cover adjacent to base joint. Place a bar across the top of the cover, locating in the castellations. The cover can now be unscrewed from the base using the bar as a lever.
Weatherproof models: The cover can be removed by unscrewing the single hexagon nut at the crown of the cover.
- Connect electrical wiring via the conduit entries using a suitable cable gland. Note that the base of the enclosure is rotatable on the pressure tube to allow the most convenient orientation of the conduit entry.
Refer to wiring notes on page 4.
On models with flameproof enclosures type ★7★ the switch mechanism may be raised on the pressure tube to ease access to the Terminal Block. Ensure that the switch mechanism is re-positioned to its lowest position (i.e. sitting on the limit tube around the pressure tube) after wiring.
- Switch point adjustment may now be made if necessary. See page 8.
- The lugs of the tab washer directly underneath the base must now be bent over to locate on the most appropriate flats of the hexagon union. This prevents further rotation of the switch head, and is particularly important as it will prevent rotation when the cover is removed or re-fitted.
- Check the cover seals are present and in good condition, and then replace the cover.
 - Before energizing** flameproof / Type ★7★ models, ensure the cover locking safety grub screw is replaced and tightened. Do not energize if the cover locking safety grub screw is missing.
 - Before energizing** weatherproof / Type ★4★ models, ensure the weatherproofing fibre sealing washer at the crown nut is in place.

Floats for 3" NB mounting : 11F

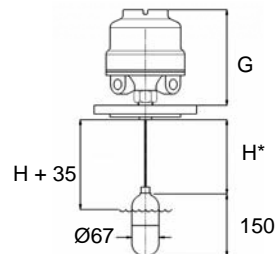

*Float rod may be shortened to suit

H dimension when used with :	11F		Switch adjustment	Wet switching differential
	Min H	Max H		
R4N R7A R71	155	315	none	20mm
S4N S7A S71	155	315	94mm	114mm max.
L4N				

Floats for 4" BB mounting : 12F, 13F, 14F

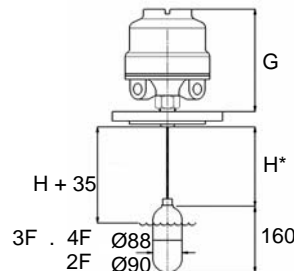

*Float rod may be shortened to suit

H dimension when used with :	12F, 13F, 14F		Switch adjustment	Wet switching differential
	Min H	Max H		
R4N R7A R71	155	415	none	20mm
S4N S7A S71	155	415	94mm	114mm max.
L4N	155	415	194mm	214mm max.

Operating Levels	
Lowest operating levels	H + 35
Highest operating levels : see adjustment notes	(H + 35) – (B + 20) where B is the max. switch adjustment from table on page 8.

Installation, operation & maintenance instructions

IP152, Rev AD

April 2012

Level

Switching Point Adjustment

Each switch mechanism is mounted on a bracket, which is secured on the pressure tube by a locking screw and lock nut. These can be loosened, allowing the bracket to be adjusted up or down as required. Always ensure that the small pressure plate between the locking screw and pressure tube is in place before re-tightening the locking screw nut.

Important note: Switches can not be adjusted outside of the range set by the stops on the pressure tube. Displacer operation controls are covered in Installation Instruction booklet IP153

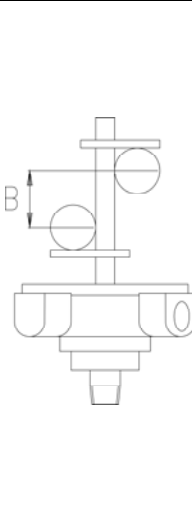

Enclosure type		Switch Mechanism Type		
		D4, P4, X4	H4	D8, P8, X8, H8
Max. No. Switches	R7A	1	1	7
Sw. Adjustment 'B'	R7I	7	7	7
Max. Wet switching differential	R4N	Type 11F, 12F, 13F, 14F : 20mm		
Max. No. Switches	S7A	4	4	2
Sw. Adjustment 'B'		94	94	94
Max. Sw Crs 'B'	S7I	94	94	94
Min. Sw Crs 'B'	S4N	7	0	56
Max. Wet switching differential		Type 11F, 12F, 13F, 14F : 114mm		
Max. No. Switches	L4N	6	6	3
Sw. Adjustment 'B'		194	194	194
Max. Sw Crs 'B'		194	194	194
Min. Sw Crs 'B'		7	0	56
Max. Wet Switching differential	Type 11F, 12F, 13F, 14F : 214mm			

Float Rod Length Adjustment

The highest operating level given by the float rod as supplied can be made higher (i.e. nearer the mounting point) by shortening the float rod on site, as follows:

Remove float unit from control by locating the Stop Assembly in the base of the 1" NPT threaded boss and easing the spring clip out of the two locating holes in the pressure tube. The rod and the magnet assembly can now be withdrawn from the pressure tube. Undo the hexagonal float adaptor to remove the float from the rod, and slide the adaptor up the rod. Hacksaw the stainless steel rod to the required length according to the diagram below, and then re-clench the rod end in a vice as shown. Re-fit the float, ensuring the spring washer is used between float and adaptor.

Re-fit the float unit to the switch head, ensuring that the magnet is free from swarf and debris. Locate the two ends of the spring clip in the two cross holes in the pressure tube; ensuring that the rod and magnet assembly are free to move vertically in the pressure tube and that it is securely retained by the Stop Assembly.

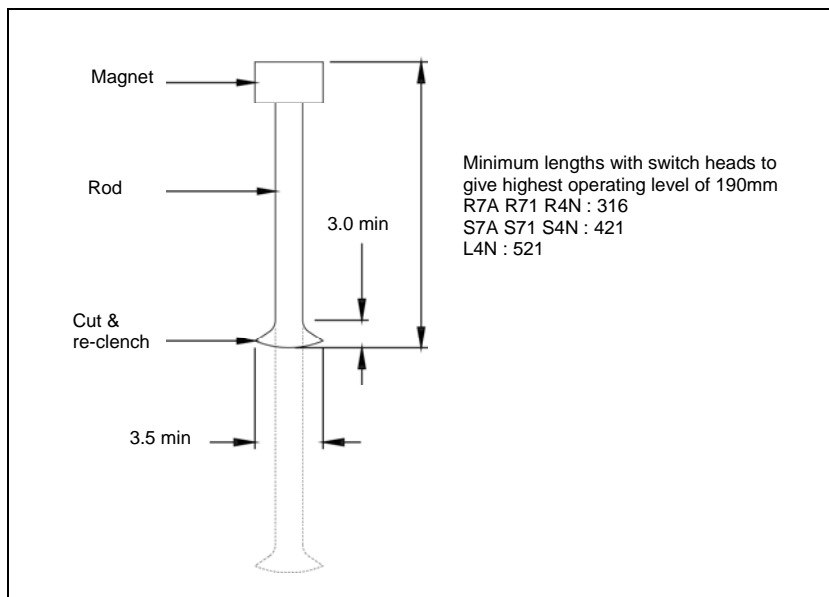

Level

Maintenance of the Mobrey vertical level controls

Inspection and maintenance shall be carried out by suitably trained personnel in accordance with applicable codes of practice.

Series B-Vertical Integral Type

This type of control is of the 'sealed chamber' type and the float or displacer mechanism cannot be removed.

However, the switch mechanisms and switch head should be visually checked periodically.

1. **Isolate electrical circuits to control and disconnect wiring as necessary.**
2. Remove the switch head cover and examine the switch mechanism body for any damage. Ensure that wiring is in good order and that all the screws are tight. **Dismantling of switch unit is not recommended and replacement of the complete switch unit will be found to offer the quickest and most economical solution in event of faulty operation.** See page 10.
3. Check sealing gasket / "O" ring and replace if necessary.
4. Check the cover seals are present and in good condition, and then replace the cover.
 - (i) **Before energizing** flameproof / Type ★7★ models, ensure the cover locking safety grub screw is replaced and tightened. Do not energize if the cover locking safety grub screw is missing.
 - (ii) **Before energizing** weatherproof / Type ★4★ models, ensure the weatherproofing fibre sealing washer at the crown nut is in place.

Series X - Vertical Flanged Type

This type of control is flanged between the switch head and chamber such that the float may be withdrawn and removed from the chamber for inspection.

1. **Isolate electrical circuits to control and disconnect wiring as necessary.**
2. Isolate the chamber from the pressure vessel by closing the isolation valves, and open the valve of the drain connection.
3. Remove nuts holding control to chamber, carefully withdraw switch head and float assembly, taking care not to bend the float rod.
4. Separate float assembly from switch head by removing stop clip.
5. Inspect the chamber and remove any deposits.
6. Check float, float rod and magnet for excessive wear, clean and replace as necessary.
7. Fit replacement joint and reassemble, taking care not to bend the float rod. Firmly tighten nuts on top flange, using bolt torque values given in tables on page 12.
8. Remove the switch head cover and examine the switch mechanism body for any damage. Ensure that wiring is in good order and that all the screws are tight. **Dismantling of switch units is not recommended and replacement of the complete switch unit will be found to offer the quickest and most economical solution in event of faulty operation.** See page 10.
9. Check sealing gaskets / "O" ring and replace if necessary.
10. Check the cover seals are present and in good condition, and then replace the cover.
 - (i) **Before energizing** flameproof / Type ★7★ models, ensure the cover locking safety grub screw is replaced and tightened. Do not energize if the cover locking safety grub screw is missing.
 - (ii) **Before energizing** weatherproof / Type ★4★ models, ensure the weatherproofing fibre sealing washer at the crown nut is in place.
11. Close drain valve connection, open isolating valves and check that the control is operating at the correct levels.

Series D - Direct Mounted Type

This type of control is mounted directly onto the process vessel, or may be mounted in a chamber.

1. **Isolate electrical circuits to control and disconnect wiring as necessary.**
2. Ensure the vessel is vented to atmosphere, or isolate any chamber from the vessel by closing the isolating valves, and open the valve of the drain connection.
3. Remove nuts holding control to chamber or vessel. Carefully withdraw switch head and float assembly, taking care not to bend the float rod.
4. Separate float assembly from switch head by removing stop clip.

Installation, operation & maintenance instructions

IP152, Rev AD

April 2012

Level

5. Inspect the chamber or stilling tube and remove any deposits.
6. Check float, float rod, and magnet for excessive wear, clean and replace as necessary.
7. Fit replacement joint and reassemble, taking care not to bend the float rod. Use bolt torque values given in tables on page 12.
8. Remove the switch head cover and examine the switch mechanism body for any damage. Ensure that the wiring is in good order and that all screws are tight. **Dismantling of switch units is not recommended and replacement of the complete switch unit will be found to offer the quickest and most economical solution in event of faulty operation.**
See page 10.
9. Check sealing gaskets / "O" ring and replace if necessary.
10. Check the cover seals are present and in good condition, and then replace the cover.
 - (i) **Before energizing** flameproof / Type ★7★ models, ensure the cover locking safety grub screw is replaced and tightened. Do not energize if the cover locking safety grub screw is missing.
 - (ii) **Before energizing** weatherproof / Type ★4★ models, ensure the weatherproofing fibre sealing washer at the crown nut is in place.
11. If the control is mounted into a chamber, close drain valve connection, open isolating valves and check that the control is operating at the correct levels.

Level

When fitting a spare or replacement switch mechanism

IMPORTANT NOTE

If a spare switch mechanism is fitted at any time, it is important that the magnet system is left in the correct mode.

After installation of a replacement switch mechanism, always check that the B-B contacts are made, assuming the chamber is empty of liquid. If the chamber is full of liquid, then A-A contacts should be checked to ensure they are made.

If it is found that a switch mechanism is not in the correct mode, then the liquid level in the chamber should be raised such that the primary float magnet passes through the switching point. Lowering the liquid level will then cause the float magnet to fall back through the switching point, thus leaving the switch mechanism in the correct operating mode (For a control operating as low level alarm, the liquid level should be first lowered then raised back to ensure the switch mechanism is in the correct operating mode).

Full fitting instructions are supplied with each spare or replacement switch mechanism.

1	Switch mechanism kit comprising Switch mechanism and fittings		Series B,X,D Weatherproof	Series B,X,D Weatherproof
	4 Contact 5 Amp	D4	SK178	SK178
	4 Contact plated	P4	SK179	SK179
	4 Contact 10 Amp	X4	SK180	SK180
	4 Contact sealed	H4	SK181	SK181
	8 Contact 5 Amp	D8	SK182	SK182
	8 Contact plated	P8	SK183	SK183
	8 Contact 10 Amp	X8	SK184	SK184
	8 Contact sealed	H8	SK185	SK185
	Sales Kit		SK190	SK191

		Series B	Series X	Series D
1	Float unit only	11F	N/A Sealed Chamber	SK192
		12F		SK193
		13F		SK194
		14F		SK195
		17D		SK196

		Series B	Series X	Series D
2	Complete float assembly, comprising float unit and rod and magnet assembly	11F	N/A Sealed Chamber	Contact factory with full model number and complete assembly can be supplied
		12F		
		13F		
		14F		
		17D		

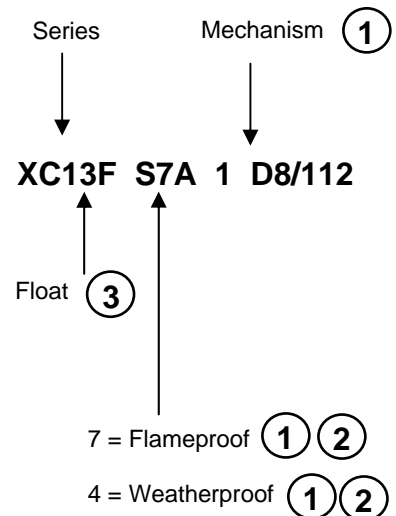
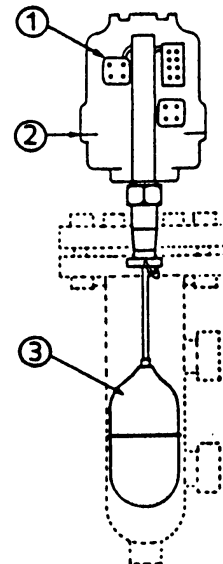

Installation, operation & maintenance instructions

IP152, Rev AD

April 2012

Level

Bolting Torques

Information in this section is to the best of our knowledge correct. Since conditions of use are beyond our control users must satisfy themselves that bolt/torques are suitable for the flange/process/conditions of the applications.

Bolting Torque details: High tensile steel bolts

IMPORTANT:-

For use with high tensile steel bolts only

Mobrey Measurement use high tensile bolts/studs as standard for pressure vessel flange applications which allows use to full switch rating. The following recommended torques assume the use of high tensile bolts. If ordinary carbon steel bolts are fitted see below for bolt tightening torques.

Min. Torques in Nm (lbf. Ft) Max. torque = Min + 10%

Flange	Class 150		Class 130	
3"	230	(169)	125	(169)
4"	190	(140)	220	(140)
6"	352	(260)		

Flange	PN16		PN40	
DN65	185	(136)	80	(59)
DN80	125	(92)	95	(70)
DN100	125	(92)	150	(111)
DN125	195	(144)	225	(166)
DN150	255	(188)	280	(206)

MOBREY A	34 (25)
MOBREY G	26 (20)

Bolting torque details: Carbon steel bolts only

Min. torques in Nm (lbf. Ft) Max. Torque – Min + 10%

Flange	Class 150		Class 300	
3"	54	(40)	95	(70)
4"	54	(40)	95	(70)
6"	95	(70)		

Flange	PN16		PN40	
DN65	58	(43)	58	(43)
DN80	58	(43)	58	(43)
DN100	58	(43)	113	(83)
DN125	58	(43)	194	(143)
DN150	113	(83)	194	(143)

MOBREY A	20 (15)
MOBREY G	20 (15)

Bolt torques for SPIRAL WOUND gaskets with a compression stop : high tensile steel bolts only.

Bolt Size	Nm	Lbf. ft
5/8"	122	90
3/4"	203	150
7/6"	325	240
1"	499	368
1 – 1/8"	722	533
1 – 1/4"	101	750

Gasket compression for joints without compression stops : high tensile steel bolts only.

Initial gasket thickness	Compressed thickness	Compression
1.6mm	1.3/1.4mm	0.2/0.3mm
2.5mm	1.9/2.0mm	0.5/0.6mm
3.2mm	2.3/2.5mm	0.7/0.9mm
4.4mm	3.2/2.5mm	1.0/1.2mm
6.4mm	4.6/5.1mm	1.3/1.8mm

IMPORTANT:-

For use with carbon steel bolts only

If ordinary carbon steel or similar lower quality bolts are used the torques recommended are as shown on the left.

The gasket sealing force created by the application of these torques is not sufficient to withstand full flange pressure rating. To achieve full rating, use high tensile steel bolts as above.

If in doubt about your bolt/sealing application consult your engineering department or gasket manufacturer.

Level

Bolts should be lubricated with suitable grease.

Correct bolt tightening sequence:-

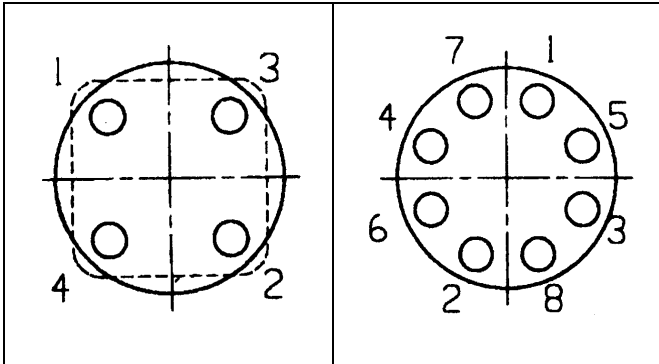

IMPORTANT NOTE: Sheet gasket materials

This product contains or is fitted with non asbestos gaskets in accordance with BS7531 Grade X, which specifies maximum operating temperatures as follows:

Gas/steam/vapor	250°C
Liquid	400°C

If your application is in excess of these limits, a suitable alternative gasket should be fitted.

Level



The Emerson logo is a trade mark and service mark of Emerson Electric Co.

Rosemount is a registered trademark of Rosemount Inc.

Mobrey is a registered trademark of Mobrey Ltd.

All other marks are the property of their respective owners

We reserve the right to modify or improve the designs or specifications of product and services at any time without notice.

© 2012 Mobrey Ltd. All rights reserved.

International:

**Emerson Process Management
Mobrey Measurement**

158 Edinburgh Avenue
Slough, Berks, SL1 4UE, UK
Tel: +44 (0) 1753 756600
Fax: +44 (0) 1753 823589
www.mobrey.com

Americas:

**Emerson Process Management
Rosemount Measurement**

8200 Market Boulevard
Chanhassen, MN US 55317
Tel: (USA) 1 800 999 9307
Tel: (International) +1 952 906 8888
Fax: +1 952 906 8889