

# Mobrey

## magnetic level switches

### Section 1: Storage & Handling M310-1

For instructions specific to ATEX Approved Flameproof models in Hazardous Area Installations, refer to accompanying leaflet M310/SI Exd or M310/SI-Sub. For Instructions specific to ATEX enclosed break (nC) models in Hazardous Area installations refer to accompanying leaflet M310/SI-Exn

- General purpose
- Hoseproof & submersible
- Chemical duty
- Flameproof  
Zone 1, gas group ATEX II 1/2G EExd IIC T6

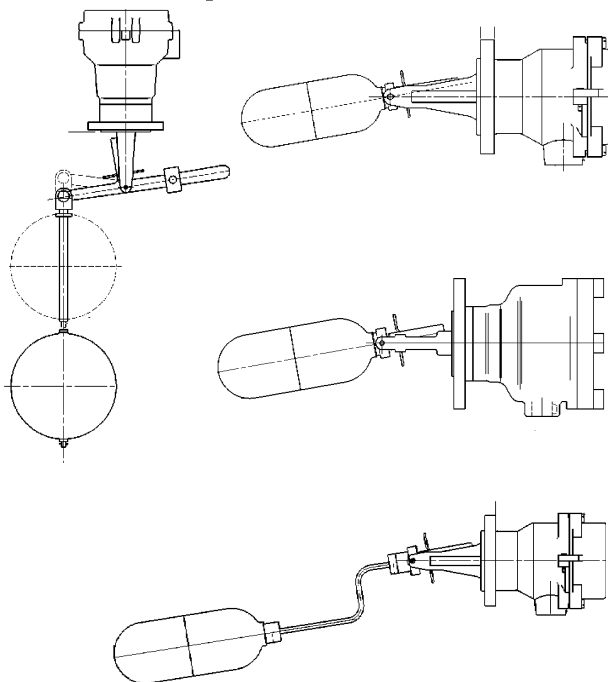

#### Storage & handling

Mobrey magnetic level switches should be handled with care and respect at all times. They are level detection **instruments** and, whilst being of robust construction, should not be dropped or subjected to any mechanical abuse that could cause damage.

The switches should be stored on suitable racking in clean and dry conditions, and the factory packing and/or boxes should not be removed until the switch is ready for installation. The storage area should not experience ambient temperatures below 1°C, or above 60°C, and/or 70% humidity (RH).

These switches contain strong permanent magnets, so they should not be stored in close proximity to sources of electro magnetism or other strong magnets. Switches in boxes may be stacked together without damage, but stacks must be such that the boxes are not crushed or damaged.

Mobrey switches have a shelf life in excess of 10 years provided the above precautions are followed.

When the switch is called for installation, it is essential that this manual is kept with the switch to guide the user in correct installation, resulting in a long and trouble free operation.

**This product contains no asbestos or other harmful material which require notification or controlled disposal.**

**KEEP DRY**



**FRAGILE**



**INSTRUMENT:  
WITH CARE**



**mobrey**

www.mobrey.com



**EMERSON**  
Process Management

The complete Mobrey Horizontal float switch range

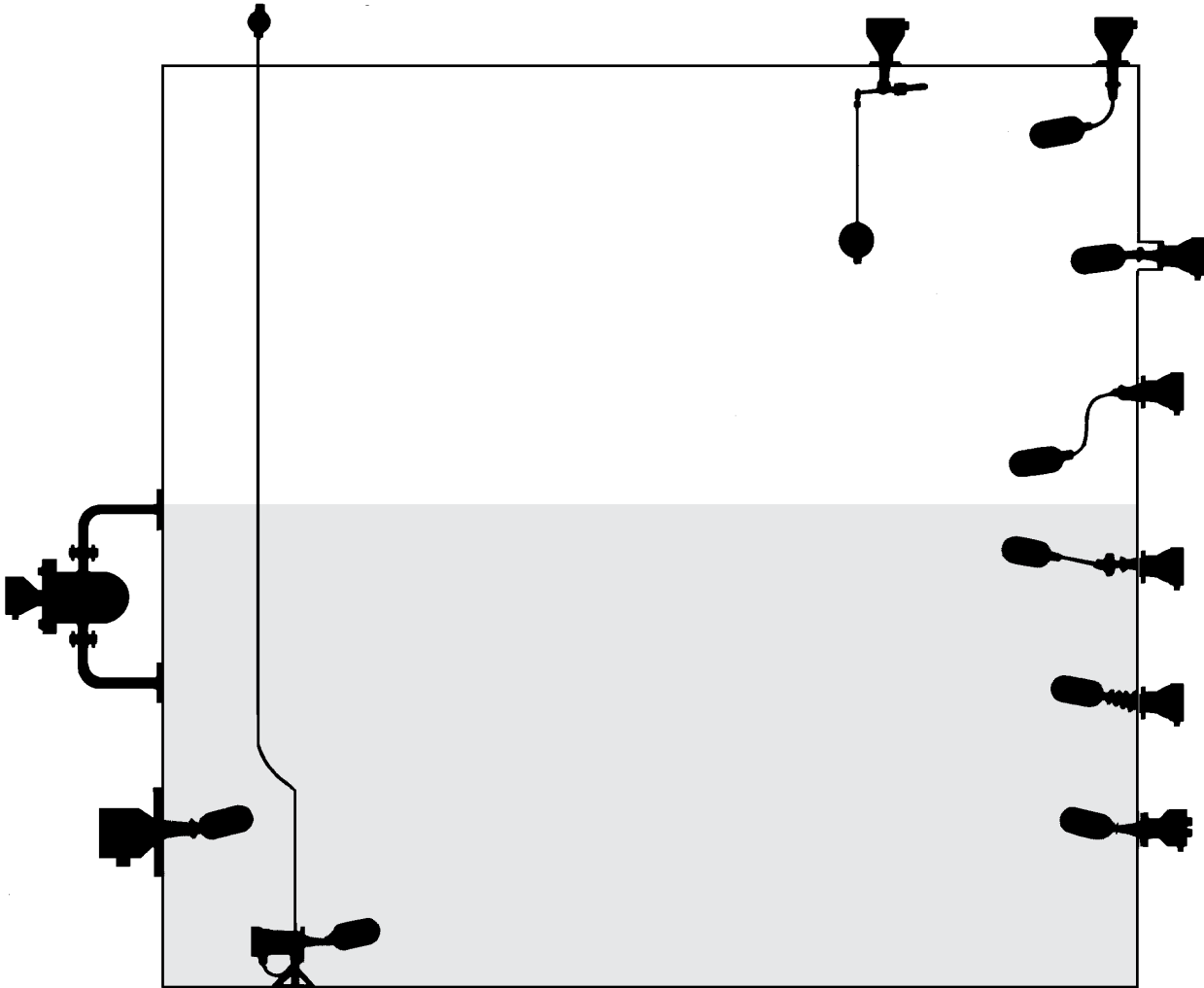

# Mobrey magnetic level switches

## Section 2: Installation M310-2

### Direct mounting level switches

(Direct into vessel).

Unpack the Mobrey magnetic level switch from its box and remove all packing pieces, tie strings and tape. The gasket supplied with this product is a non-asbestos composite and must be handled with care to avoid damage.

This switch contains strong permanent magnets: Ferrous debris or particles may become attached to the float magnet. Always check the float magnet is clean before final installation.

The level switch should be positioned so that the float may move freely over its full travel and not foul the sides, bottom or top of the tank etc., in which it is mounted.

Positions where turbulence may be caused by agitators or by inlet connections should be avoided.

The plant should be clear of any loose materials or metallic particles which might accumulate round the float magnet and interfere with the operation of the switch.

Where the liquid may contain sediment or solid particles, particular attention must be given to keeping these free of the float assembly.

When mounted the switch flange should be vertical within two degrees either way. A table of mounting flange details is given on Page 2-2.

When fitted to an open tank or sump, not under pressure, the switch may be mounted through a hole cut in the tank and secured with bolts or studs. Mobrey 'companion' flanges are available to facilitate mounting - details on page 2-2.

Mobrey magnetic level switches have the type number stamped on a nameplate fixed either to the end cap,

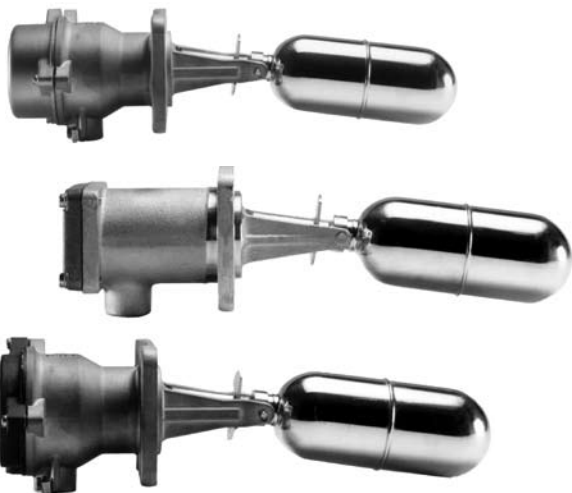

switch body or on the terminal box. For catalogue models the type number bears the prefix 'S' for the switch head and 'F' for the float unit. The float unit carries a permanent magnet which is opposed magnetically to a similar magnet in the switch assembly. The switch contacts are changed over with a snap action by magnetic repulsion between the magnets, acting across the wall of the switch body. No intermediate 'off' position can be obtained. Variations to catalogue models are identified by a 7\*\*\*\*/\*\*\* type number. The nearest standard production type number is also quoted on the equipment nameplate to allow identification of the relevant paragraphs in this manual.

### Level Switches for vertical mounting

A suitable mounting bracket is required for mounting the switch over open top tanks and sumps.

*Note: The diameter of a standard float on a vertical float rod is larger than the hole required for the switch head and the float must therefore be fitted from inside the vessel.*

The switch should be conveniently positioned at a point of access for both installation and maintenance.

Care should be taken to ensure that condensation cannot drain down the conduit into the switch head.

### Switches in pressurised vessels

A studded pad is necessary where the switch is required to operate in a pressure vessel.

See page 2-3 for flange and bolting data.

### Level switches in chambers

Mobrey magnetic level switches supplied in or with an external chamber (cage) are supplied loosely assembled only. It is the responsibility of the installer to check that all packaging, tie strings, tapes and filler materials are moved from around and inside the chamber and switch before the assembly is bolted down and in accordance with the torque settings given on page 2-3.

When installing, using or maintaining external chambers supplied compliant with the Pressure Equipment Directive, refer also to the Safety Information (Leaflet No. M310/SI) supplied with the product for further details.

Switches mounted in chambers external to the main vessel should be fitted with suitable valves so that the chamber may be blown down periodically or isolated for routine maintenance as required.

## Mounting flange details

Mobrey magnetic level switches have raised face flanges, and are supplied with non-asbestos gaskets. Details of mating flanges required for standard Mobrey flanges are shown below :-

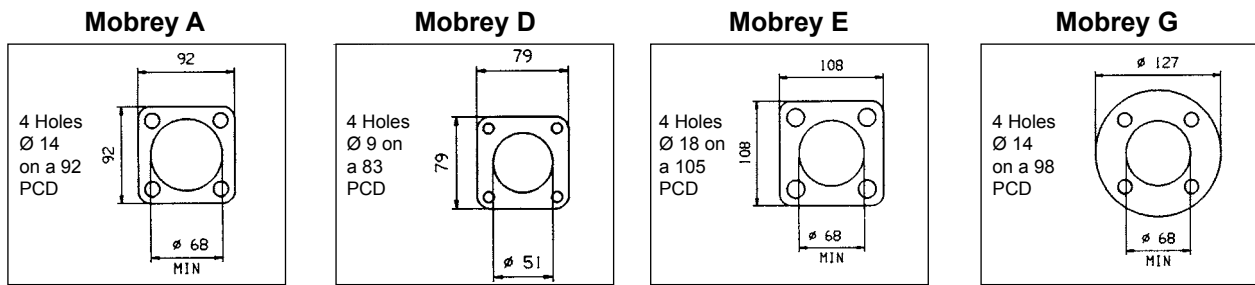

To facilitate mounting of Mobrey flange switches, the following mounting accessories are available :-

### For 'A' Flange

Weld on pad J184  
Weld on nozzle J786  
Backing flange for GRP tanks J863

### For 'G' Flange

Weld on pad J800  
Weld on nozzle J799

Studs	Flange			
	A	D	E	G
Size mm	12	8	16	12
Projection mm	30	16	35	35

(Refer to installation instructions supplied with backing flange kit)

Switches with international flanges are in accordance with international flange standards. The flange is of composite design, with a stainless steel fork flange which supports the float and also forms the raised face of the flange, and a loose ring back flange. These composite flanged switches have a back flange alignment pin to ensure correct orientation. **The pin must be located in recess in fork flange before tightening mounting bolts.**

Switch head	Flange	Conduit thread	Air connection option
S01	Mobrey A	M20	APV
S03	Mobrey A	M20	-
S36	Mobrey A	M20	APV
S163	Mobrey A	Pg16	-
S179	Mobrey A	M20	-
S181	Mobrey A	Pg16	-
S183	Mobrey A	M20	-
S187	Mobrey A	M20	-
S189	Mobrey A	M20	-
S190	Mobrey A	M20	-
S195	Mobrey A	M20	-
S250	Mobrey G	-	-
S251	3" 300lb ANSI	-	-
S253	DN 80 PN40	The gunmetal body has M25	-
S254	4" 300lb ANSI	-	-
S255	DN 100 PN40	-	-
S256	3" 150lb ANSI	-	-
S257	4" 150lb ANSI	-	-
S260	3" 600lb ANSI	The alluminium body has M20	-
S261	3" 900lb ANSI	-	-
S268	DN100 PN 64	-	-
S269	DN125 PN40	-	-
S270	DN125 PN64	-	-
S271	DN150 PN64	-	-
S272	DN80 PN64	-	-
S275	Mobrey G	-	-
S278	Mobrey G	-	-
S357	Mobrey A/E	Pg16	-
S417	DN65 PN 40	M20	APV
S418	DN80 PN 40	M20	APV
S419	DN100 PN 40	M20	APV
S424	3" 300lb ANSI	M20	APV
S425	4" 300lb ANSI	M20	APV
S428	DN65 PN16	M20	APV
S429	DN80 PN16	M20	APV
S430	DN100 PN16	M20	APV
S431	DN125 PN16	M20	APV
S432	DN150 PN16	M20	APV
S433	DN125 PN40	M20	APV
S434	DN150 PN40	M20	APV
S435	DN100 PN64	M20	APV
S436	DN125 PN64	M20	APV
S437	DN150 PN64	M20	APV
S440	3" 150lb ANSI	M20	APV
S441	4" 150lb ANSI	M20	APV
S488	DN80 PN64	M20	APV
S489	3" 600lb ANSI	M20	APV
S490	3" 900lb ANSI	M20	APV

Switch heads are available with air pilot valve switching where shown APV. In this case, air connections are brass compression couplings to suit 6.0mm Copper or nylon pipe. (Coupling thread: 1/4" BSP)

Information in this section is to the best of our knowledge correct. Since conditions of use are beyond our control users must satisfy themselves that bolt/torques are suitable for the flange/process/conditions of the applications.

### Bolting torque details : High tensile steel bolts

#### IMPORTANT :-

#### For use with high tensile steel bolts only

Mobrey uses high tensile bolts/studs as standard for pressure vessel flange applications which allows use to full switch rating. The following recommended torques assume the use of high tensile bolts. If ordinary carbon steel bolts are fitted see below for bolt tightening torques.

Min. torques in Nm (lbf. ft.). Max. torque = Min + 10%

Flange	#150	#300
3"	230 (169)	125 (92)
4"	190 (140)	220 (169)
6"	352 (260)	

Flange	PN16	PN40
DN65	185 (136)	80 (59)
DN80	125 (92)	95 (70)
DN100	125 (92)	150 (111)
DN125	195 (144)	225 (166)
DN150	255 (188)	280 (206)

MOBREY A	34 (25)
MOBREY G	26 (20)

#### Bolt torques for SPIRAL WOUND gaskets with a compression stop: high tensile steel bolts only.

Bolt size	Nm	lbf.ft
5/8"	122	90
3/4"	203	150
7/8"	325	240
1"	499	368
1 - 1/8"	722	533
1 - 1/4"	101	750

#### Gasket compression for joints without compression stops: high tensile steel bolts only.

Initial gasket thickness	Compressed thickness	Comp-ression
1.6mm	1.3/1.4mm	0.2/0.3mm
2.5mm	1.9/2.0mm	0.5/0.6mm
3.2mm	2.3/2.5mm	0.7/0.9mm
4.4mm	3.2/3.4mm	1.0/1.2mm
6.4mm	4.6/5.1mm	1.3/1.8mm

### Bolting torque details : Carbon steel bolts only

Min torques in Nm (lbf.ft) Max torque = min + 10%

Flange	#150	#300
3"	54 (40)	95 (70)
4"	54 (40)	95 (70)
6"	95 (70)	

Flange	PN16	PN40
DN65	58 (43)	58 (43)
DN80	58 (43)	58 (43)
DN100	58 (43)	113 (83)
DN125	58 (43)	194 (143)
DN150	113 (83)	194 (143)

MOBREY A	20 (15)
MOBREY G	20 (15)

#### IMPORTANT :-

#### For use with carbon steel bolts only

If ordinary carbon steel or similar lower quality bolts are used the torques recommended are as shown on the left.

The gasket sealing force created by the application of these torques is not sufficient to withstand full flange pressure rating. To achieve full rating, use high tensile steel bolts as above.

If in doubt about your bolt/sealing application consult your engineering department or gasket manufacturer.

Bolts should be lubricated with suitable grease.

Correct bolt tightening sequence :-

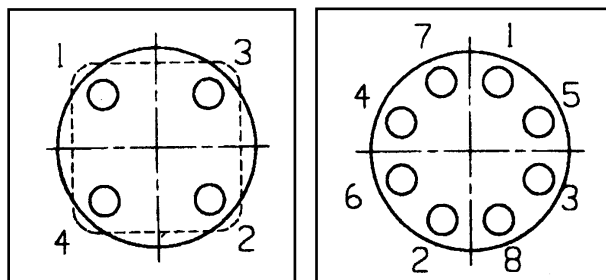

#### IMPORTANT NOTE: Sheet gasket materials

This product contains or is fitted with non asbestos gaskets in accordance with BS7531 Grade X, which specifies maximum operating temperatures as follows:

Gas/steam/vapour	:	250°C
Liquid	:	400°C

If your application is in excess of these limits, a suitable alternative gasket should be fitted.

**Adjustments : Switches for horizontal mounting - pump control duty.**

Switches fitted with F68 type float unit may be adjusted on site to meet pump control differential requirements. The F68/4 has pre-drilled holes along the rod to allow the user to achieve the /2 and /3 differentials in the table below.

Simply cut the rod to the required length as shown on the drawing below:-

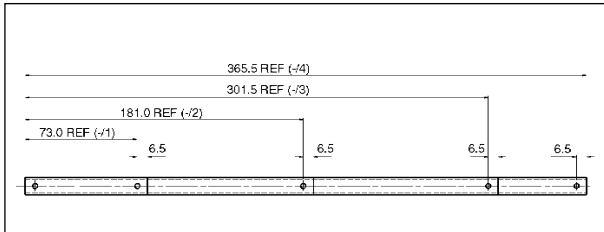

**Switches for horizontal mounting**

The operating levels and differentials may be varied by locating the stops in accordance with the details shown in the table below.

Positive dimensions give the switch change-over position above the centre line. Negative dimensions give the switch change-over position below the centre line. To alter stop positions: withdraw split pin, move stop to new location, re-insert split pin and open out to lock. These dimensions are approximate for cold water and will vary for liquids of different S.G.

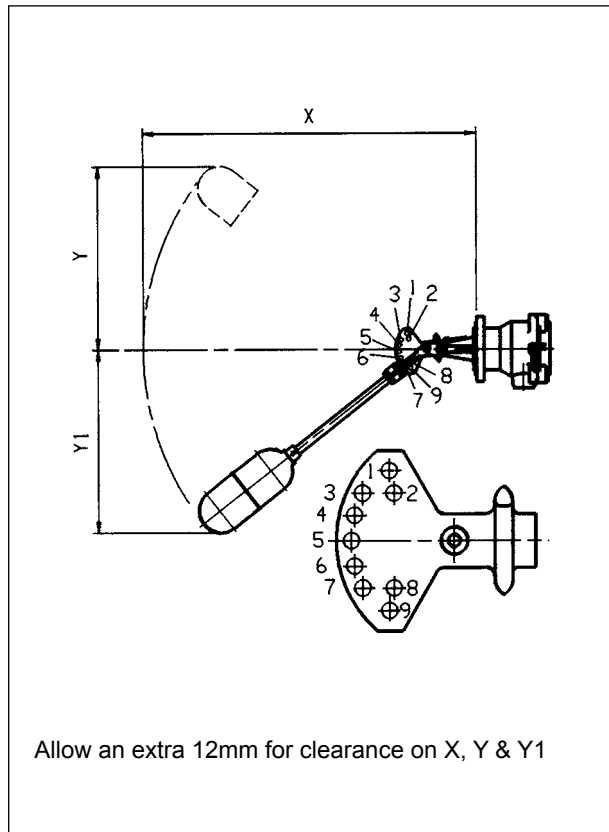

**Float rod lengths and differentials for F04 and F68 floats**

Stop position	F68/1 Overall length X = 360 Min. SG 0.72					F68/2 Overall length X = 470 Min. SG 0.80					F68/3 Overall length X = 590 Min. SG 0.82					F68/4 Overall length X = 643 Min. SG 0.85				
	Level about centre line			Min. tank dims.		Level about centre line			Min. tank dims.		Level about centre line			Min. tank dims.		Level about centre line			Min. tank dims.	
	High	Low	Diff	Y	Y1	High	Low	Diff	Y	Y1	High	Low	Diff	Y	Y1	High	Low	Diff	Y	Y1
1 - 4	+137	+ 113	24	216	63	+198	+ 165	33	292	63	+270	+224	46	368	63	+301	+247	54	406	63
1 - 5	+137	+ 59	79	216	63	+198	+ 86	112	292	63	+270	+114	156	368	63	+301	+127	174	406	63
1 - 6	+137	+ 5	132	216	102	+198	+ 8	190	292	114	+270	+ 10	260	368	140	+301	+ 6	295	406	154
1 - 7	+137	- 44	181	216	152	+198	- 67	265	292	190	+270	- 90	360	368	241	+301	- 101	402	406	266
1 - 8	+137	- 67	204	216	178	+198	- 100	298	292	229	+270	- 137	407	368	292	+301	- 155	456	406	323
1 - 9	+137	- 110	247	216	216	+198	- 162	360	292	292	+270	- 213	483	368	368	+301	- 254	555	406	406
2 - 5	+ 94	+ 59	35	178	63	+137	+ 86	51	229	63	+189	+114	75	292	63	+203	+127	76	323	63
2 - 6	+ 94	+ 5	89	178	102	+137	+ 8	129	229	114	+189	+ 10	179	292	140	+203	+ 6	197	323	154
2 - 7	+ 94	- 44	138	178	152	+137	- 67	204	229	190	+189	- 90	279	292	241	+203	-101	304	323	266
2 - 8	+ 94	- 67	161	178	178	+137	- 100	237	229	229	+189	- 137	326	292	292	+203	- 155	358	323	323
2 - 9	+ 94	- 110	204	178	216	+137	- 162	298	229	222	+189	- 213	402	292	368	+203	- 254	457	323	406
3 - 5	+ 70	+ 52	18	152	63	+102	+ 78	24	190	63	+140	+105	35	241	63	+158	+127	31	266	53
3 - 6	+ 68	+ 5	63	152	102	+ 98	+ 8	90	190	114	+137	+ 10	127	241	140	+158	+ 6	151	266	154
3 - 7	+ 68	- 44	112	152	152	+ 98	- 67	165	190	190	+137	- 90	227	241	241	+158	- 101	259	266	266
3 - 8	+ 68	- 67	135	152	178	+ 98	- 100	198	190	229	+137	- 137	274	241	292	+158	- 155	313	266	323
3 - 9	+ 68	- 110	178	152	216	+ 98	- 162	260	190	292	+137	- 213	350	241	368	+158	- 254	412	266	406
4 - 6	+ 17	+ 2	15	102	102	+ 27	+ 2	25	114	114	+44	+ 10	36	140	140	+ 38	+ 6	32	154	154
4 - 7	+ 17	- 44	61	102	152	+ 25	- 67	92	114	190	+44	- 90	134	140	241	+ 38	- 101	139	154	266
4 - 8	+ 17	- 67	84	102	178	+ 25	- 100	125	114	229	+44	- 137	181	140	292	+ 38	- 155	193	154	232
4 - 9	+ 17	- 110	127	102	216	+ 25	- 162	187	114	292	+44	- 213	257	140	368	+ 38	- 254	283	154	406
5 - 7	- 32	- 49	17	63	152	- 49	- 75	25	63	190	- 70	- 102	32	63	241	- 69	- 101	32	63	266
5 - 8	- 35	- 67	32	63	178	- 54	- 100	46	63	229	- 73	- 137	64	63	292	- 69	- 155	86	63	323
5 - 9	- 35	- 110	75	63	216	- 54	- 162	108	63	292	- 73	- 213	140	63	368	- 69	- 254	185	63	406
6 - 9	- 84	- 110	26	63	216	- 27	- 162	35	63	292	- 163	- 213	51	63	368	- 184	- 254	70	63	406

## Adjustments: Switches for vertical mounting; pump control or alarm duty

Switches with F21 type float unit must be set on site to perform either alarm or pump control duty. Stops on the float rod are moved up or down to set the levels at which the switch contacts change over.

### Level alarm

The switch can be used for either high or low level alarm, but one switch cannot perform both functions. To provide both high and low level alarm, two switches must be fitted. The float rod has two adjustable stops; the lower stop should be positioned on the float rod at about 75mm below the required switching point. The upper stop must be positioned at the top of the float rod (it is not used in alarm mode). Without the weight of the float bearing on the stop, the counter-balance weight is down, holding the float rod in the up position. For low level alarm the weight of the float bearing on the stop will cause the switch to change over.

For high level alarm the float lifting off the stop will allow the counter balance weight to raise the float rod, so causing the switch to change over. The switch will revert to the normal position as soon as the liquid level withdraws from the alarm point.

### Pump control

The counter balance weight balances out the weight of rod and stops, excluding the float. At low level, additional weight of float bearing on bottom stop operates switch. At high level, buoyancy of the float lifting against top stop operates the switch. The switch remains in its switched position until the liquid level alters to the opposite extreme.

Note: This arrangement must not be used for level alarm duties.

On no account should the float rod be cut shorter after the balance weight has been positioned, as the balance of the system will be upset.

The position of the balance weight should be adjusted as detailed in leaflet (L1832) supplied with the float assembly.

If the float rod needs to be shortened, this must be carried out before the balance weight is adjusted.

### LOW LEVEL ALARM Normal (left) and alarm position

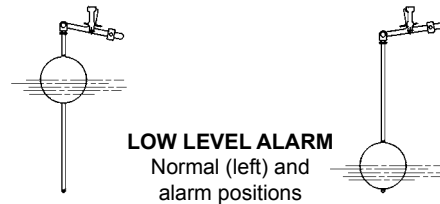

### HIGH LEVEL ALARM Normal (left) and alarm positions

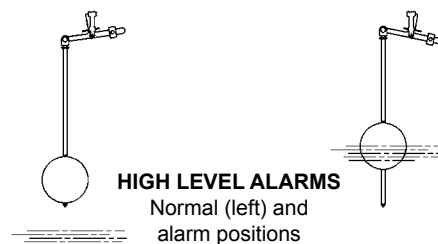

### PUMP CONTROLS Low level (left) and high level (right)

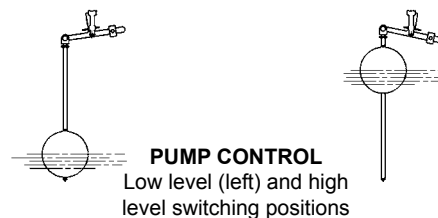

Electrical characteristics and wiring details

**Type D & D\* switches (eg S01DB, S36DA, or S179DB)**

RATING :	A.C.	D.C. Inductive	D.C. Resistive
Max. voltage V	440	240	240
Max. current A	8.0*	1.0	2.0
Max. power	2000 VA	35 Watts	70 Watts
	Power factor 0.4 Min	Time constant 40 ms max	

\* Note : Max. current above 210°C is 5.0A

Two independent single pole single throw contact sets.

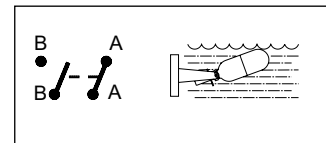

AA makes on rising level

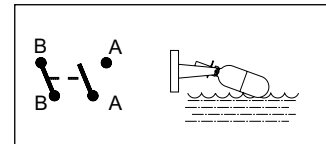

BB makes on falling level

**Type D6\*, H6\* & B6\* switches (eg. S36D6A or S424H6A)**

RATING :	A.C.	D.C. Inductive	D.C. Resistive
Max. voltage V	440	240	240
Max. current A	5.0	1.0	2.0
Max. power	2000 VA	35 Watts	70 Watts
	Power factor 0.4 Min	Time constant 40 ms Max	

Double pole change over :  
Two independent circuits.  
See Note V on page 2-7

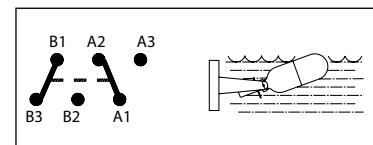

A<sub>1</sub>-A<sub>2</sub>  
B<sub>1</sub>-B<sub>3</sub> Make on rising level

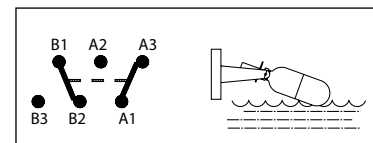

A<sub>1</sub>-A<sub>3</sub>  
B<sub>1</sub>-B<sub>2</sub> Make on falling level

The H6\* & B6\* switch may be used for switching low power (e.g. intrinsically safe) electrical circuits, provided the limits specified for the P\* or P6\* are not exceeded. (See note i) on page 2-7)

## Notes on electrical wiring and connections

i) Type, **P\*** OR **P6\*** switches  
(eg S01PB, S36PA or S424P6A)

These switches have the same electrical configuration as their respective D\* and D6\* versions. However, the ratings are greatly reduced in order to protect the plated contacts:

The plating may be permanently damaged if this insert is used to switch circuits above the following limits:

	Resistive		Inductive
300V:	12mA	24v:	2mH/200mA
24V:	250mA	24v:	750mH/10mA

ii) Connections:

Refer to page 2-2 for details of conduit/connection sizes.

iii) Direct starting of motors

Mobrey switches can be used for the direct starting of small motors (1/10HP) only. For larger motors, switches should be used in series with the operating coils of relays, contactors or solenoid valves and fused separately.

iv) High temperatures

Suitable heat-resisting cable should be used where switch heads are subject to temperatures in excess of ambient.

v) Type **D6**, **P6**, **D6B**, **P6B**, **H6** & **B6** switch mechanisms. Different voltages may be applied to A and B circuits respectively, but differing voltages must not be applied to circuits on the same side.

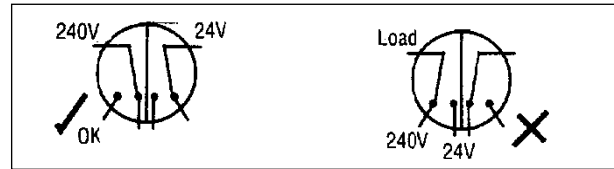

vi) Earthing

It is recommended that the earthing terminal(s) provided are used to earth the level switch, particularly when the switch is fitted to non-metallic or coated vessels or flanges.

### LVD - Low Voltage Directive

These switches comply with the provisions of the Low Voltage Directive 73/23/EEC.

Standards applied: EN60947 Parts 1 and 5.1

**NOTE: A cable gland is supplied in the box with the S01DB, S179, Mini-switch, and S36 range.**

It is a brass cable gland, nickel plated, with a fully insulated neoprene seal and with clamping range to suit 8mm to 13mm OD cable.

Protection type IP68. The cable gland has temperature resistance -20°C to +180°C although maximum 80-110°C as a permanent temperature on application.

## Air pilot valve characteristics

Type AP\* & AM\* Switches  
(eg. S01 APA or S36 AMA)

Type **AP**:

Maximum air pressure valve: 7 bar (100 psi)

Maximum air flow through valve: 66 litres/min at 7 bar.

Air must be clean and dry.

Type **AM**:

Maximum air pressure through valve 1.4 bar (20psi)

Air must be clean and dry.

Note that with Type AM inserts, the magnet is in attraction with the float magnet, not in repulsion as shown in the diagrams alongside which apply to Type AP inserts

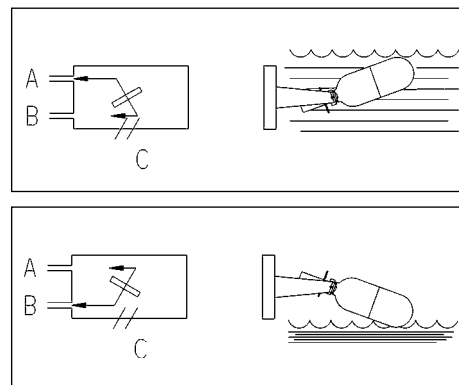

Connect air operated device to port C.

Connect air supply to either port A or B.

Unused port becomes the exhaust.

Although connections are identical, Type AP cannot be used as Type AM, or vice-versa.

## Operation

Once installed in accordance with section 2.0, the Mobrey magnetic level switch is ready for operation.

A test may be made by lifting the float by hand to check

that the float moves freely and the relevant alarm or pump control relays operate. On no account try to operate the float with a rigid rod which could cause damage to the float itself.

# Level

## P\*, P6\*, H\*, H6\*, AM\*, AP\* Switch Mechanisms - Simple Apparatus

These Switch Mechanisms do not have a potential source of ignition for an explosive atmosphere, during normal intended use, a malfunction or even a rare malfunction. They do not fulfil the definition of equipment in Article 1 (3) of Directive 94/9/EC (Equipment Explosive Atmospheres (ATEX)) and are therefore outside the scope this Directive and do not have a Declaration of Conformity or CE mark related to this Directive.

The P\*, P6\*, H\*, H6\* switch mechanisms in a standard switch housing are classified as "Simple Apparatus" only when used in Intrinsically Safe circuits. They comply with the requirements of EN50014:1997, General Requirements and EN50020:2002, clause 5.4 'Simple Apparatus' and are not considered as a potential source of ignition for an explosive atmosphere.

When used as "Simple Apparatus" within a hazardous atmosphere the following should be noted:

1. The product should be installed by suitably trained personnel, in accordance with the applicable code of practice.
2. As the product has no source of internal heating, the temperature classification is dependent on the ambient air temperature and the temperature of the process vessel to which it is attached.
3. Materials of construction: Refer to product catalogue or customer drawing for actual material of level switch concerned.

Housing and Cover: Stainless Steel 316 type, or Aluminium Alloy LM25 or LM 24, or Aluminium Bronze AB1, or Gunmetal LG2

Fork Flange: Stainless Steel types 316, 321 or 347, or Gunmetal LG2, or Aluminium Bronze AB1, or Halar coated Stainless steel, or Alloy 400, or Alloy C276 or Alloy 625, or Alloy 825

If the equipment is likely to come into contact with aggressive substances, it is the responsibility of the user to take suitable precautions that prevent it from being adversely affected, thus ensuring that the type of protection is not compromised.

Aggressive substances: e.g. acidic liquids or gases that may attack metals or solvents that may affect polymeric materials.

Suitable precautions: e.g. regular checks as part of routine inspections or establishing from the material's data sheet that it is resistant to specific chemicals.

Note: The metallic alloy used for the enclosure material may be at the accessible surface of this equipment; in the event of rare accidents, ignition sources due to impact and friction sparks could occur. This shall be considered when the switch is being installed in locations that specifically require group II, category 1G equipment.

4. It is the responsibility of the user to ensure:
  - a. The joint requirements between the switch housing and vessel are compatible with the process media.
  - b. The joint tightness is correct for the joint material used.
  - c. That suitable temperature rated cable is used.
 

**Note:** The cable entry temperature may exceed 70°C
  - d. The float is protected from impact or friction, or static electrical build-up from fast flowing non-conductive fluids, that could generate an ignition source.

The Emerson logo is a trade mark and service mark of Emerson Electric Co.  
 Rosemount is a registered trademark of Rosemount Inc.  
 Mobrey is a registered trademark of Mobrey Ltd.  
 All other marks are the property of their respective owners  
 We reserve the right to modify or improve the designs or specifications of product and services at any time without notice.

*International:*  
**Emerson Process Management**  
 Mobrey Measurement Division  
 158 Edinburgh Avenue, Slough,  
 Berks SL1 4UE, UK  
 T +44 (0)1753 756600  
 F +44 (0)1753 823589  
 www.mobrey.com

*Americas:*  
**Emerson Process Management**  
 8200 Market Boulevard  
 Chanhassen, MN USA 55317  
 T (US) (800) 999-9307  
 T (International) (952) 906-8888  
 F (International) (952) 949-7001



**EMERSON**<sup>TM</sup>  
 Process Management

# Mobrey

## magnetic level switches

### Section 3: Maintenance and spares M310-3

#### Maintenance

Mobrey magnetic level switches are designed for long and trouble free operation, provided regular routine maintenance is carried out in accordance with the recommendations below:-

- (1) Switch off electrical supply and isolate or drain down as necessary.
- (2) Remove level switch from tank or chamber.
- (3) Remove deposits of sludge, scale etc. Any tightness in the movement of the float assembly or the pivot pin should be investigated and corrected.
- (4) Remove any metallic particles adhering to the float magnet assembly by wiping with plasticine. Avoid contamination by swarf, etc, on benches and tools.
- (5) On switches with shrouded float units, the shroud and gaiter should be stripped and any solids which have collected on the inside removed.
- (6) The gasket should be replaced and the switch installed and bolted down in accordance with the installation instructions given in Section 2.

#### To examine or replace internal switch assembly

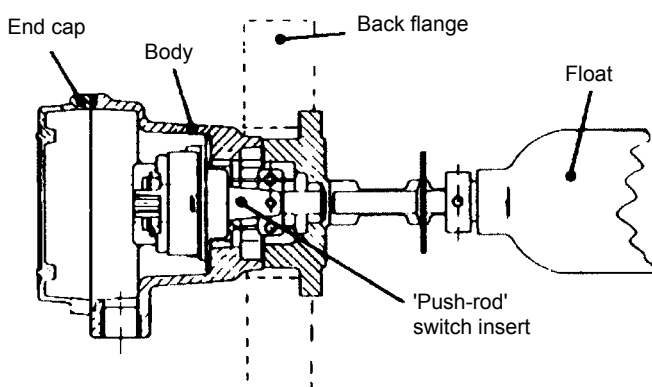

#### a) Type D\*, P\*, D6\*, P6\*, H6\* and B6\* Switches (eg S36DA, S424H6A, S179DB, S01DB)

- i) Unbolt end cover & open on hinge.
- ii) Disconnect wiring.
- iii) Unscrew two cheese head screws retaining switch mechanism (pan head in the case of the H6 and B6 type mechanism) and withdraw switch mechanism.
- iv) Ensure that interior of switch body is clean and dry.
- v) Manually operate magnet on switch insert from side to side - do not handle roughly - and check that magnet returns to its mid-position when released. (Does not apply to type H6 and B6 mechanism.)
- vi) Examine pivot points and check that they are free of dirt or contamination and do not hinder or restrict magnet movement. (Does not apply to H6 and B6 mechanism.)

#### If any parts require replacement, a complete internal switch mechanism must be fitted.

- vii) Replace switch aligning mechanism so that locating lug engages in slot in mounting plate. (Switches fitted with Type H6 and B6 mechanism do not have a mounting plate in switch body - the mechanism can only be fitted in one position, determined by the fixing screws.) It is essential to ensure that no swarf or debris has become attached to the magnet or entered the switch body.

# Level

---

Note that Type H6 and B6 mechanism seats on the diaphragm of the fork flange, and is held in position by a spring clamp plate. Ensure switch insert operates correctly when replaced by manually operating float.

viii) Re-connect electrical wiring

ix) Check that 'O' ring seal is in good order - replace if necessary then close end cover and secure with three fixing bolts.

## **b) Type AP\* & AM\* switches (eg S01APA or S36 AMA)**

i) Uncouple air connections from valve block.

ii) Unscrew three retaining bolts and withdraw valve block.

iii) Ensure that interior of switch body is clean and dry.

iv) Manually operate magnet on valve block - do not handle roughly - check that magnet pivots freely and ensure there is no dirt or contamination on pivots which could hinder magnet movement.

## **Replace valve block if found faulty.**

v) Replace valve block in switch body ensuring that no dirt or debris has become attached to the magnet. Check 'o' ring seal, replace if necessary, then replace three fixing bolts and reconnect air lines.

---

## **Spares**

Each Mobrey magnetic level switch has a set of recommended spare parts which are available from Mobrey Measurement at the address below, or from your local appointed agent.

These genuine Mobrey spare parts are supplied in kit form so that all the relevant components and assemblies are included, ensuring fast and reliable servicing of the product.

Please contact Mobrey Measurement in the event of any difficulty in the installation, operation or maintenance of the product. A member of our spares and repairs department will be happy to assist.

Thank you for buying a Mobrey magnetic level switch. We are confident it will give you years of reliable and trouble free operation.

The Emerson logo is a trade mark and service mark of Emerson Electric Co.

Rosemount is a registered trademark of Rosemount Inc.

Mobrey is a registered trademark of Mobrey Ltd.

All other marks are the property of their respective owners

We reserve the right to modify or improve the designs or specifications of product and services at any time without notice.

### *International:*

#### **Emerson Process Management**

Mobrey Measurement Division  
158 Edinburgh Avenue, Slough,  
Berks SL1 4UE, UK  
T +44 (0)1753 756600  
F +44 (0)1753 823589  
www.mobrey.com

### *Americas:*

#### **Emerson Process Management**

8200 Market Boulevard  
Chanhassen, MN USA 55317  
T (US) (800) 999-9307  
T (International) (952) 906-8888  
F (International) (952) 949-7001