

Mobrey Series 9700

Hydrostatic level transmitter



Features

- Loop powered
- 4 to 20mA output
- Intrinsically safe option
- +/- 0.1% accuracy
- 10:1 rangeability
- Spans from 0.2 to 200 m H₂O
- Integral or remote calibration
- Good long-term stability
- Ceramic capacitive sensor
- Wide range of process connections
- Direct process mounting
- Approved by the world's leading Marine Classification societies

Contents

Section	Page
1 Specification	2
2 Product overview	3
3 Installation	4
4 Wiring diagrams	5
5 Calibration	7
6 Fault finding	10
7 CSA Approval	10
8 CSA Control drawing	11
9 Integral cable length	11

The 9700 Hydrostatic Level Transmitter is a measuring instrument and should be handled with due care and attention at all times.

- Do not swing sensor by the cable
- Do not drop or impact the sensor



Section 1 : Specification

Functional

	9710, 9720, 9780 Suspended in tank	9790 External to tank
Output signal :	Two-wire, 4-20mA	Two-wire, 4-20mA
Power supply :	10-30V d.c.	10 - 30V d.c.
Load resistance :	R = 50 x (supply voltage -10V) Ω	R = 50 x (supply voltage -10V)Ω
Measuring ranges :	Up to 200m / 8" to 656ft H ₂ O	Up to 200m / 8" to 656ft H ₂ O
Overrange limit :	Max 600m / 1968ft H ₂ O	Max 600m / 1968ft H ₂ O
Span adjustments :	+10 to 100% URL*	+10 to 100% URL*
Process temp. limits :	-20 to + 60°C / -4 to +140°F	-20 to + 90°C (80°C Ex ia)
(non certified)		
Ambient temp. limits :	-20 to + 60°C	-20 to + 60°C
Humidity limits :	0 to 100% RH	0 to 100% RH
Hazardous area use :	ATEX II 1 G EEx ia IIB T4	ATEX II 1 G EEx ia IIB T4
Cable specification :	CSA (Canada & USA) Capacitance 500 pF/metre Refer to Section 4	CSA (Canada & USA) Capacitance 500p F/metre Refer to Section 4

Performance

	9710, 9720, 9780 Suspended in tank	9790 External to tank
Accuracy :	+/- 0.1% (BSL)** of calibrated span	+/- 0.1% (BSL)** of calibrated span
Stability :	+/- 0.1% URL* per 6 months	+/- 0.1% URL* per 6 months
Temperature effect :	+/- 0.015% URL per °C	+/- 0.015% URL per °C
Response time :	See Section 5.5	See Section 5.5

Physical

	9710, 9720, 9780 Suspended in tank	9790 External to tank
Process connection :	Submersible	Flange mounted
Wetted Parts :		
Sensor :	Ceramic	Ceramic
Sensor Housing :	316 St. Steel or Aluminium Bronze	316 St. Steel or Aluminium Bronze
Sensor 'O' Rings :	Fluorocarbon (FPM/FKM) Nitrile	Fluorocarbon (FPM/FKM) Nitrile
Body 'O' Rings	Fluorocarbon (FPM/FKM) or Nitrile	Fluorocarbon (FPM/FKM) or Nitrile
Cable Seals	Fluorocarbon (FPM/FKM) or Nitrile	Fluorocarbon (FPM/FKM) or Nitrile
Cable :	Polyurethane or FEP coated	Polyurethane or FEP coated
Pole :	316 Stainless steel pole supplied with 316 Stainless steel housing option. Copper Nickel pole supplied Aluminium Bronze Housing option	Not applicable
Ingress Protection :	IP68 / NEMA 6P (200m / 656ft H ₂ O)	IP68 / NEMA 6P (200m / 656ft H ₂ O)
Approximate weight :	0.7Kg / 1.54lbs (sensor only)	0.7Kg / 1.54lbs (sensor only)

* URL = Upper range limit

**BSL = Best straight line, includes effects of linearity, hysteresis & repeatability

Remote Enclosures

Remote enclosure :	Aluminium IP67 Grey (RAL 7001) 0.7 kg
Bellows enclosure :	Polyester IP67 Grey (RAL 7001) 1.2 kg

Section 2 : Product Overview

Simple installation, low maintenance

The 9700 is available in both submersible versions and externally mounted (floodable) versions. The housing contains the capacitive ceramic sensor and the electronics circuit board, all the components needed to produce an accurate and reliable measurement of the process. The glanding system used with the submersible versions ensures absolute integrity of the IP68 / NEMA 6P rating. IP68 / NEMA 6P units are generally factory fitted with the required length of vented cable fitted.

Protected from aggressive environments and processes

The transmitter is designed to withstand the harshest of environments. Its rugged, flush ceramic sensor is inherently capable of withstanding attack from most chemicals.

Mounting options

The 9700 is available in various mounting configurations, all are rated IP68.

- 9710 - Cable suspended
- 9720 - Clamped, cable suspended
- 9780 - Pole mounted
- 9790 - Flanged
- Threaded mounting is available upon request

Typical installation

In order to simplify installation, all 9700 series transmitters can be supplied with remote zero and span.

Remote zero and span allows zero and full scale output to be set without removing sensor from process, this option includes an IP67 junction box.

Bellows

For humid environments or sea water applications bellows must be selected. (Option 4 of zero and span)

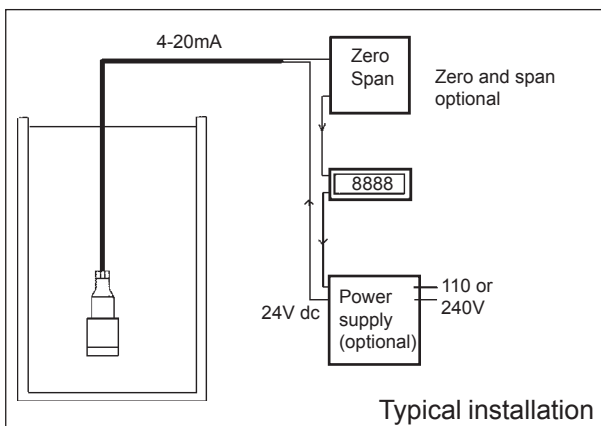
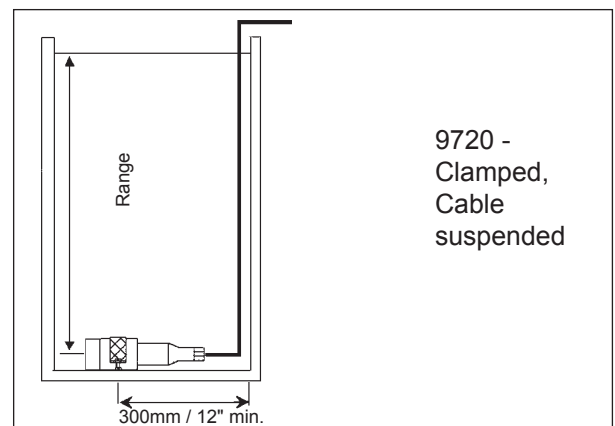
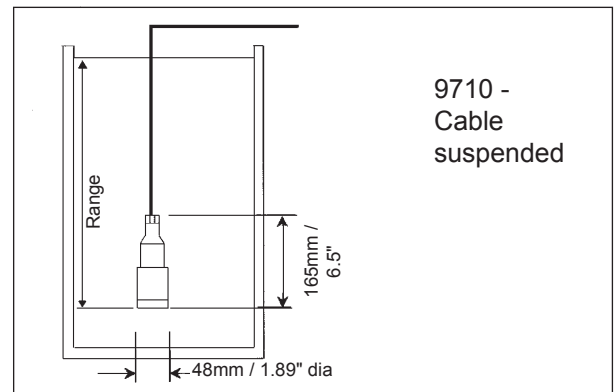
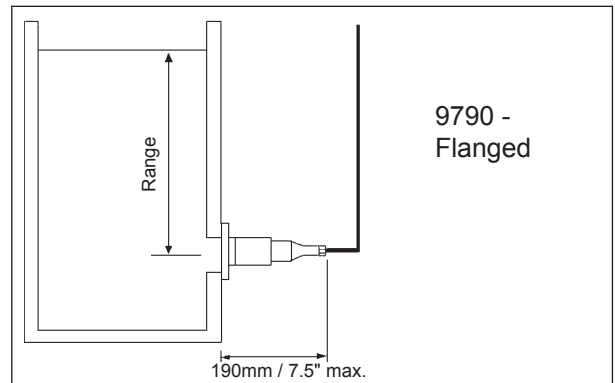
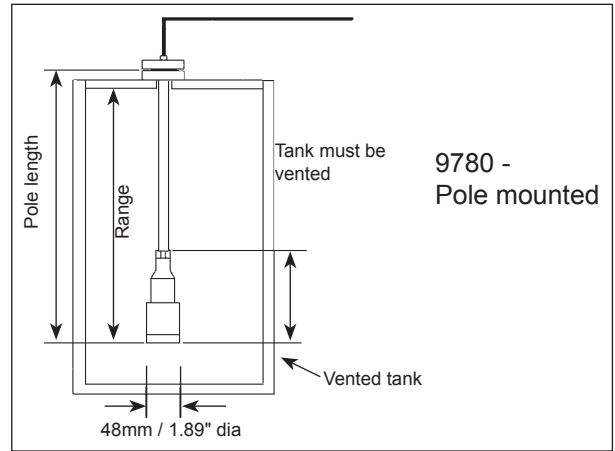

Section 3 : Installation



When installed in an explosive atmosphere refer to ATEX Safety Instructions IP341/SI and CSA control drawing 71907/1167 in Section 7.

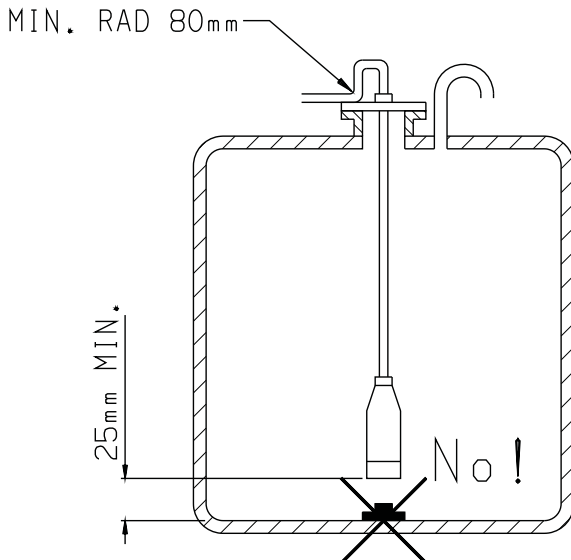

3.1 Installation considerations

The ceramic capacitive sensor is extremely rugged, however, care should be taken to avoid physical impact of solid objects onto the sensor face. Care should be taken, particularly in the case of series 9710, 9720 and 9780 submersible transmitters when lowering them into a tank, that solid objects resting on the bottom of the vessel are not in direct contact with sensor face, as this will cause large errors.

The use of Aluminium Bronze sensors is strongly recommended for application on any tanks that may contain seawater or brine to avoid the corrosive effects that may be caused by stray currents. Always check that the sensor being fitted is of the correct material for the application. All 9700 units should be installed well away from tank inlets, pumps and areas of turbulence or pressure surges, as these can cause errors or even damage the sensor.

9710 units may be suspended from the cable provided. However, in moving tanks, such as found in Marine applications, the sensor should be clamped or fixed such that damage from impacts or shock are avoided.

9790 flanged units: Ensure flange bolts are tightened evenly and that mA o/p is stable and correct prior to use.

3.2 Cable and termination

Submersible 9700 units are supplied fitted with a specified length of vented cable. In the case of units with integral electronics this should be terminated in a vented box. For units with remote electronics the vented cable is terminated in the remote electronics box.

For connection diagrams see Section 4. For applications where a long cable run is required when using integral transmitters, the use of a vented terminal box to be mounted in the nearest clean and dry area to the tank, and standard 2 core screened cable from the terminal box can often reduce cabling costs.

Terminate the cable screen to an appropriate earth point. This connection should be inspected periodically to ensure an effective contact.

In excessively humid environments and all shipboard applications, the cable must be terminated in the control room, or other clean and dry area, to minimise risk of moisture entering vent tube and ultimately the sensor. If the transmitter has been supplied with a remote electronics box, then this box must be mounted in a clean and dry area.

Alternatively the cable can be terminated into the bellows box option which provides a sealed venting system.

Ensure all cable glands are tight before use (see Section 5)

1. DO NOT drag the sensor over sharp edges.
2. DO NOT swing the sensor by the cable.
3. DO NOT bend the cable to a radius of less than 80mm radius.
4. DO check cable sheathing for signs of damage (cuts, weld spatter, burns etc.) particularly inside the tank area. Damage to the sheathing will allow process fluid to leak inside the transmitter.

3.3 Re-Ranging

All transmitters are factory calibrated over the range stated on the label on the transmitter. In most instances, if re-ranging is required, it is carried out elsewhere in the 4 - 20mA loop (e.g. the indicator, PLC or controller).

If the transmitter has been ordered with a factory fitted remote electronics option, then the transmitter may be re-ranged on site by removing the cover of the remote electronics box to give access to the adjustment potentiometers (See section 5 for full details).

All other models have factory fitted cables and are factory sealed - re-ranging of the transmitter is **not recommended** as it will require breaking of the factory seals.

Section 4 : Wiring Diagrams

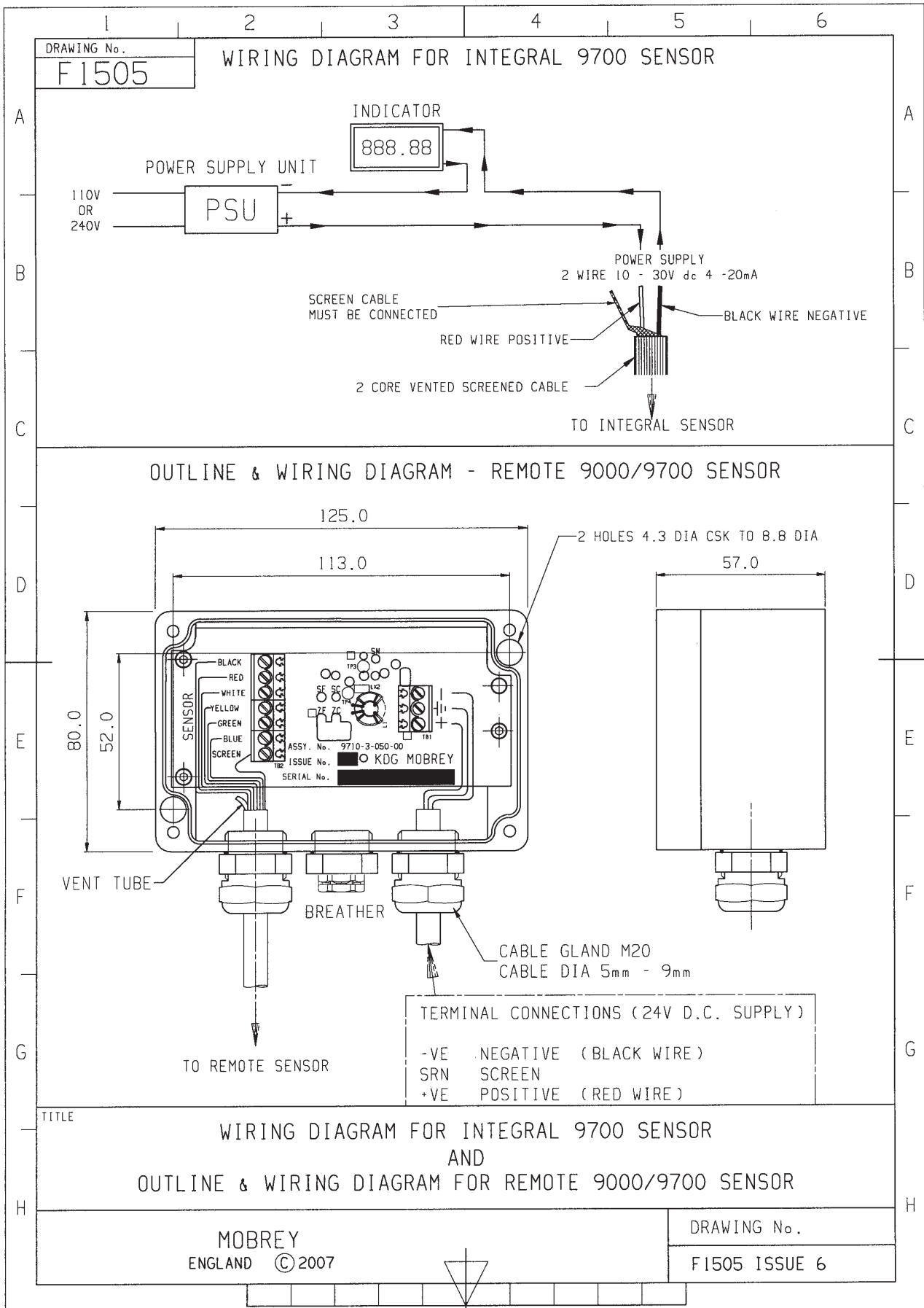

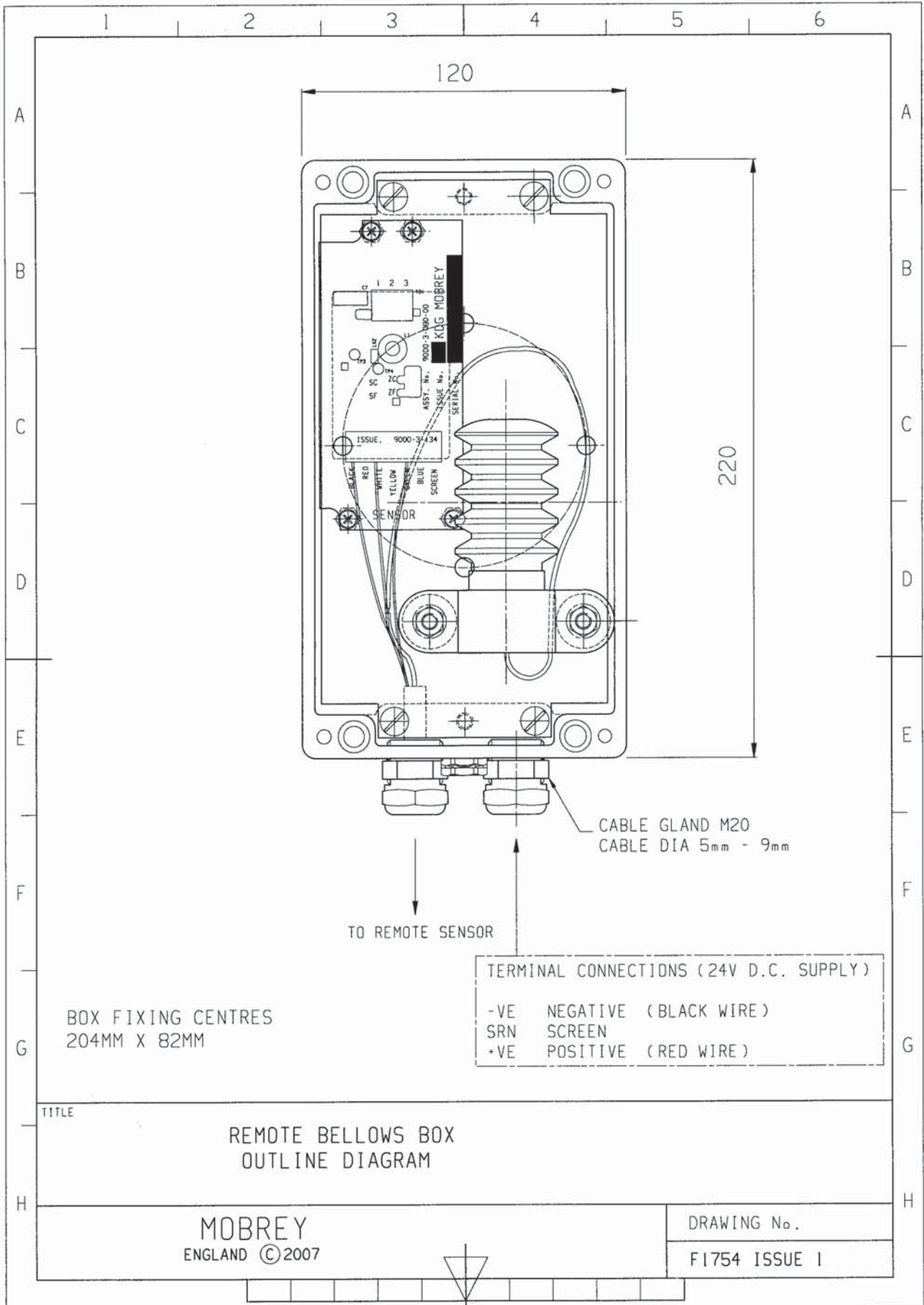

Section 5 : Series 9700 calibration

All transmitters are factory calibrated over the range stated on the label on the transmitter. In most instances, if re-ranging is required, it is carried out elsewhere in the 4 - 20mA loop (e.g. the indicator, PLC or controller).

For Series 9710, 9720, 9780, 9790 with remote electronics, simply undo the 4 screws on the front of the cover to gain access to the PCB.

For Series 9710, 9720, 9780, 9790 with integral electronics, re-calibration and re-ranging is not permitted by customer without invalidating warranty.

When calibrating series 9700 pressure and level transmitters with remote electronics, the following procedure should be followed:

NOTE : All 9700 Series Units are generally supplied pre-calibrated and ranged specifically for the application details supplied with the order.

Connect transmitter to the multimeter as shown below.

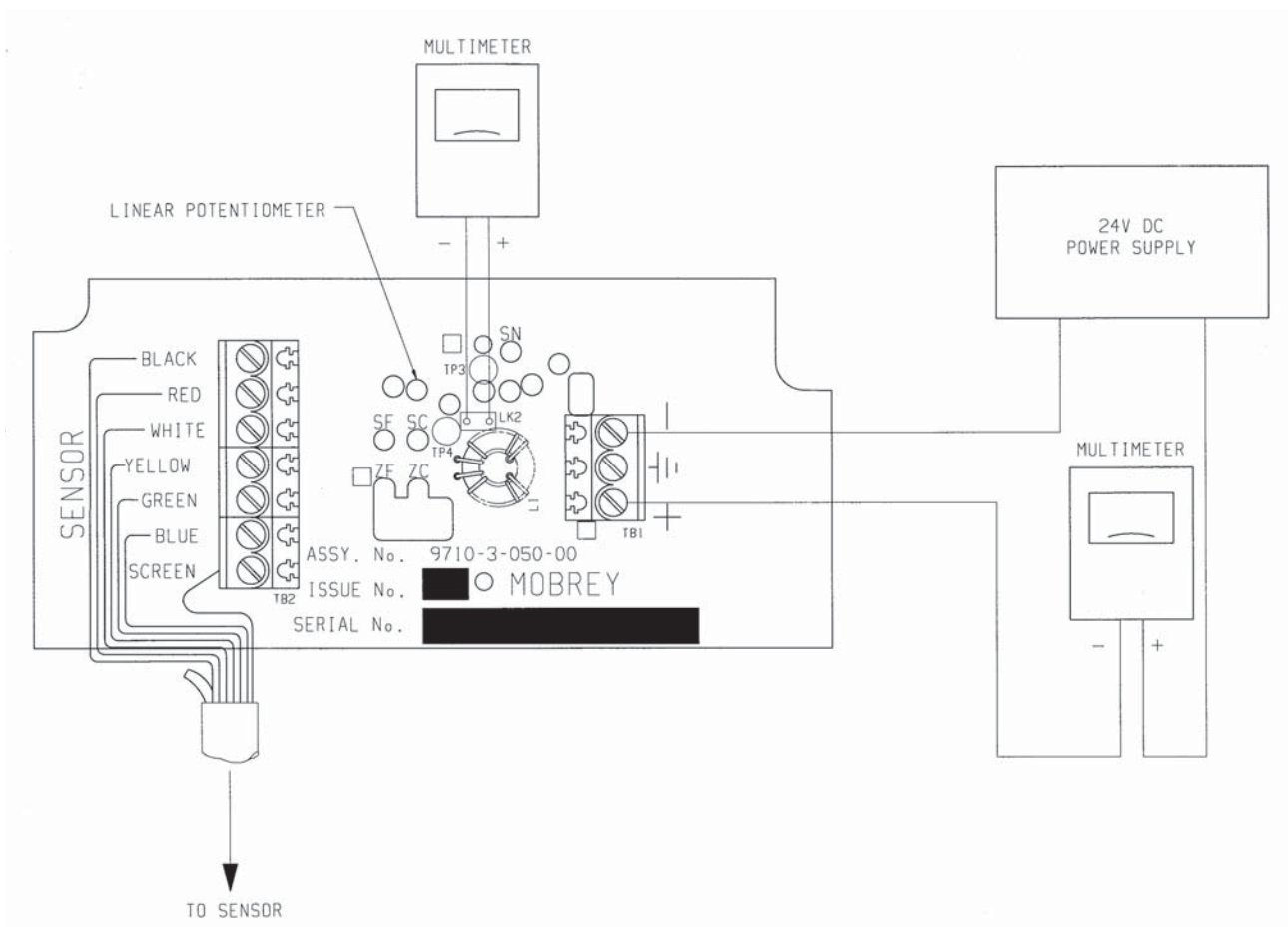

**Single loop may grounded
At any single point or left ungrounded**

Electronics housing top view (cover removed)

5.1 Re-ranging transmitter

- 5.1.1 Verify sensor range from range code shown on sensor body.
- 5.1.2 Connect 24v dc to transmitter. (12 to 30V for standard units and 10 to 30V for I.S. units)
- 5.1.3 Connect multimeter between power supply and transmitter or to link 2 as shown in diagram on Page 7.
- 5.1.4 Turn potentiometer “ZF” (fine zero adjustment) until multimeter reads 4.000mA +/- 0.005mA.
- 5.1.5 With 100% pressure / level applied, turn potentiometer “SC” (coarse span adjustment) until multimeter reads approximately 20mA.
- 5.1.6 Turn potentiometer “SF” (fine span adjustment) until multimeter reads 20.000mA +/-
- 5.1.7 Return pressure / level to 0%, multimeter should now read 4.000mA +/- 0.005mA.
- 5.1.8 Transmitter is now calibrated and ready for service.

5.2 Zero offset

- 5.2.1 For an offset zero (i.e.) lower range pressures between 20% of span below atmospheric pressure and 40% of span above atmospheric pressure it is recommended that the transmitter span is first set as in section 5.1.
- 5.2.2 The zero offset required can now be introduced by using ZF. This prevents zero / span interaction when the sensor is “off null”.

5.3 Sensor null (Normally factory set) : Replacement electronics only

NOTE: This is normally factory set and sensor null potentiometer will be sealed. ON NO ACCOUNT MUST THE SEAL BE BROKEN.

- 5.3.1 If the electronics have been changed, the sensor null (SN) will require adjustment. Connect multimeter between TP1 and TP2 using 1mm test pins.
- 5.3.2 Set multimeter to millivolt range.

5.3.3 Ensure transmitter is isolated from the process and at zero pressure.

5.3.4 Turn potentiometer “SN” until multimeter reads 0.00 millivolts, disconnect multimeter and seal the 'SN' potentiometer. Zero and span may now be set as detailed in section 5.2.

5.4 Linearisation procedure

- 5.4.1 This is normally factory set and the potentiometer sealed. ON NO ACCOUNT MUST THE SEAL BE BROKEN.
- 5.4.2 If the electronics have been changed linearisation may be required. Only on replacement electronics assemblies will the linearisation potentiometer not be sealed.

In this case having carried out the sensor nulling procedure first, the transmitter can then be linearised before being re-ranged.

- 5.4.3 Apply a pressure of 50% of nominal range. Observe percentage error and use graph to determine adjustment required on 'LIN' potentiometer, e.g. for an error of -0.1% turn LIN pot anti-clockwise by half a turn.
- 5.4.4 The linearisation potentiometer should now be sealed.
- 5.4.5 The transmitter can now be re-ranged as in Section 5.2.

Linearity Adjustment Chart

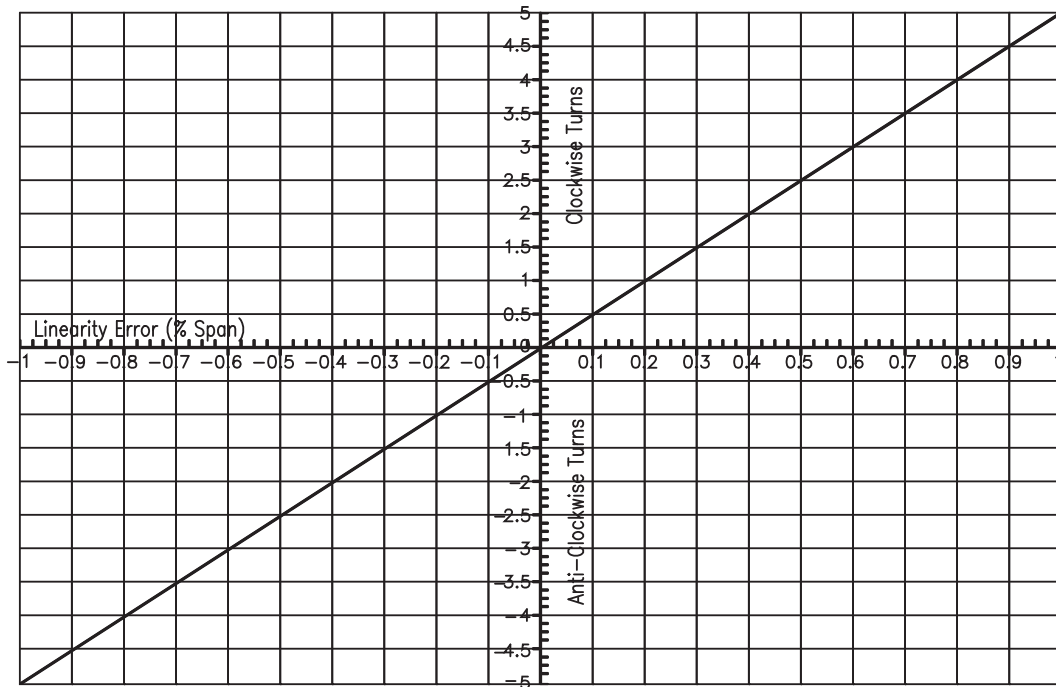

5.5 Sensor response time

5.5.1 The sensor damping can be adjusted via link 1 as shown below.

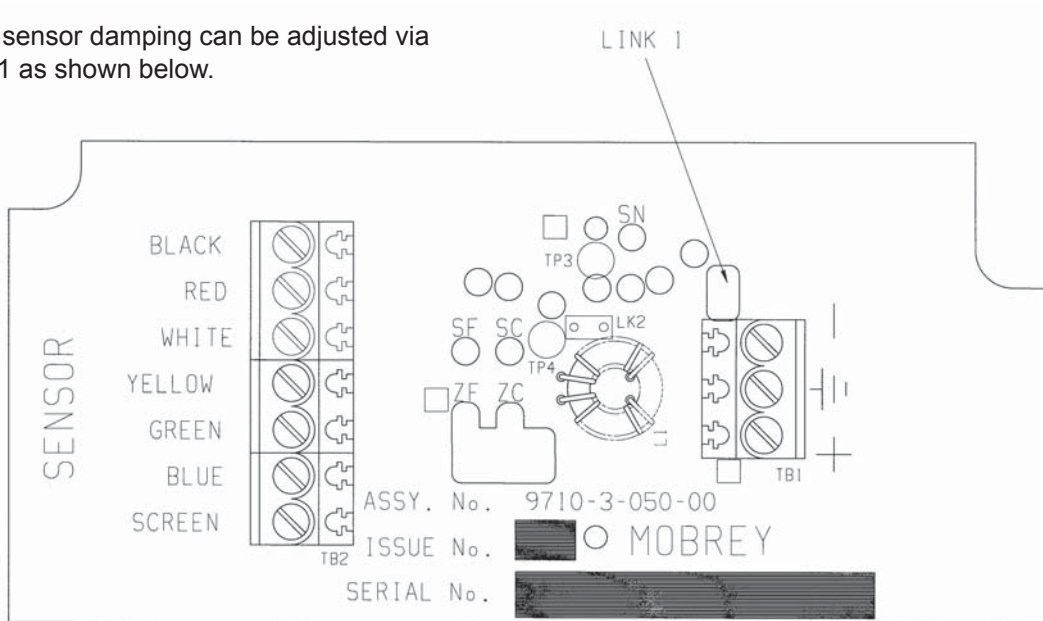

Electronics housing top view (cover removed)

5.5.2 With link 1 present the response time is approximately 60mS for a 63% response to pressure change and 150mS for a 90% response to pressure change.

5.5.3 With link 1 removed the response times become approximately 10mS for a 63% response to pressure change and 90mS for a 90% response to pressure change.

5.6 Re-assembly of the sensor

Refer to Section 5.0.

Units are supplied with link 1 fitted.

Section 6 : Fault Finding

6.1 The following is a guide to simple fault finding

6.1.1 Lightning

HIGH mA OUTPUT
NO CHANGE IN OUTPUT WITH
PRESSURE CHANGE.



REMEDY : Return to factory.
Fit new main circuit board and recalibrate
as in Section 5.

6.1.2 Moisture Condensation

FLUCTUATING OUTPUT,
CHANGING IN
STEADY SIGNAL OUTPUT
APPROX. 4 mA. NO CHANGE IN
OUTPUT WITH PRESSURE CHANGE.



REMEDY : Remove the transmitter to a
dry area and allow it to fully dry out.

6.1.3 Damaged Sensor

HIGH mA OUTPUT (VOLTAGE
OUTPUT SENSOR) APPROX.
>10mA.
NO CHANGE IN OUTPUT WITH
PRESSURE CHANGE.



REMEDY : Return to factory. Replace
sensor

6.2 Replacing main circuit board assembly

For Series 9710, 9720, 9780, 9790 it
is recommended that the main circuit
board assembly is only changed by a
qualified service engineer.

6.3 Remote transmitters

By connecting a Multimeter between
terminal 4 (the OV white) and the following
terminal in the remote transmitter, the
given voltages should be observed.
(See drawing no. F1524 in Section 4 for
terminal details).

1. Blue +1.235V (nominal) reference from
middle PCB
May be between +1.21V and
+1.26V.
2. Green +8.5V semi-stabilised from middle
PCB.
May be between +8 and +9 volts.
3. Yellow +5V supply from middle PCB to
ceramic sensor. Varies with span,
temperature compensation and
linearity correction but will
nominally be around +5.0V or
+4.85V at 25°C.
4. White OV common
5. Red Ceramic pressure sensor output.
Nominally +1 volt at zero pressure
and +4 volts at full
pressure (equal to nominal range
of the sensor).
6. Black Temperature output from bottom
PCB. Nominally +1.235V at 25°C
but will vary between +1.1 volts
and +1.5 volts over the
compensated temperature range
of -20°C to +90°C.

Section 7 : Approvals

Hazardous Area Certification :

ATEX II 1 G
ATEX II 1 GD (available upon request)
EEx ia IIB T4 Intrinsically Safe
CSA (Canada & USA)
CLI, DIV1, GPS C & D
CL II DIV1, GPS E, F & G, CL III
Ex ia IIB T4
AEx ia IIB T4

Marine Approvals :

Lloyds Register
Bureau Veritas
American Bureau of Shipping
Korean Register
Germanischer Lloyd
DNV

Section 8 : CSA Control drawing

INTRINSICALLY SAFE APPARATUS

HAZARDOUS LOCATION,
CLASS I, DIVISION 1,2 GROUPS C,D, CLASS II DIVISION 1,2 GROUPS E,F & G
CLASS III DIVISION 1,2
CLASS I, ZONES 0,1,2 Ex ia IIB T4 GROUPS IIA, IIB, T4 (T_a = -30°C TO +80°C)

ASSOCIATED CERTIFIED APPARATUS
UNCLASSIFIED LOCATION

TABLE 1

DESCRIPTION	UNIT ENTITY CONCEPT PARAMETERS		
	9000 SERIES	97*****1*	97*****2* 97*****4*
MAXIMUM INPUT VOLTAGE (U _i) (V _{max})	28V	28V	28V
MAXIMUM INPUT CURRENT (I _i) (V _{max})	333mA	333mA	120mA
MAXIMUM INPUT POWER (P _i)	0.7W	0.7W	0.7W
INTERNAL CAPACITANCE (C _i)	378nF	378nF	378nF
INTERNAL INDUCTANCE (L _i)	1.272mH	1.272mH	4.41mH

LOOP POWERED TRANSMITTER
TYPE: PRESSURE/LEVEL
TRANSMITTER
9000*****MK2
97*****
SEE TABLE 1 FOR ENTITY
CONCEPT PARAMETERS.

NOTES:

- INSTALLATION OF EQUIPMENT INCLUDING ANY GROUNDING ARRANGEMENT TO BE IN ACCORDANCE WITH CANADIAN ELECTRICAL CODE RECOMMENDED PRACTICE FOR INSTALLATION OF INTRINSICALLY SAFE CIRCUITS, OR THE INTRINSICALLY SAFE EQUIPMENT INSTALLATION PRACTICE IN THE COUNTRY OF USE.
- UNCLASSIFIED LOCATION: UNSPECIFIED EXCEPT THAT IT MUST NOT BE SUPPLIED FROM NDR CONTAIN UNDER NORMAL OR ABNORMAL CONDITIONS A SOURCE OF POTENTIAL WITH RESPECT TO GROUND IN EXCESS OF 250V RMS OR 250V DC.
- EITHER:
 - ANY APPROVED DUAL OR TWO SINGLE CHANNEL POLARISED BARRIER(S) OF THE SAME POLARITY WHOSE ENTITY CONCEPT PARAMETERS MEET THE REQUIREMENTS IN TABLE 1.
 - ANY APPROVED SINGLE CHANNEL ISOLATOR OR ONE CHANNEL OF A MULTI-CHANNEL ISOLATOR WHOSE ENTITY CONCEPT PARAMETERS MEET THE REQUIREMENTS IN TABLE 1.
 - ANY ASSOCIATED CERTIFIED EQUIPMENT WITH AN INTRINSICALLY SAFE OUTPUT WHOSE ENTITY CONCEPT PARAMETERS MEET THE REQUIREMENTS IN TABLE 1.
- THE ELECTRICAL CIRCUIT IN THE HAZARDOUS LOCATION MUST BE CAPABLE OF WITHSTANDING AN AC TEST VOLTAGE OF 500V RMS TO GROUND OR THE FRAME OF THE APPARATUS FOR 1 MINUTE.
- THE ENTITY CONCEPT ALLOWS INTERCONNECTION OF INTRINSICALLY SAFE APPARATUS, NOT SPECIFICALLY EXAMINED IN COMBINATION AS A SYSTEM, WHEN THE APPROVED VALUES OF U₀ (V₀₀) AND I₀ (I₀₀) OF THE ASSOCIATED CERTIFIED APPARATUS ARE LESS THAN OR EQUAL TO U_i (V_{max}) AND I_i (I_{max}) OF THE INTRINSICALLY SAFE APPARATUS AND THE APPROVED VALUES OF C₀ (C₀₀) AND L₀ (L₀₀) OF THE ASSOCIATED CERTIFIED APPARATUS ARE GREATER THAN THE TOTAL VALUES C_i AND L_i OF ALL THE INTRINSICALLY SAFE APPARATUS INCLUDING ALL THE CABLE.
- CABLE CAPACITANCE AND INDUCTANCE PLUS THE I.S. APPARATUS UNPROTECTED CAPACITANCE (C_i) AND INDUCTANCE (L_i) MUST NOT EXCEED THE ALLOWED CAPACITANCE (C₀ OR C₀₀) AND INDUCTANCE (L₀ OR L₀₀) INDICATED ON THE ASSOCIATED CERTIFIED APPARATUS FOR THE HAZARDOUS LOCATION.
- AN I.S. SAFETY EARTH IS NOT REQUIRED WHEN A GALVANIC ISOLATOR IS USED. IN THIS CASE THE SCREEN IF FITTED MAY BE EARTHED AT ONE POINT ONLY.
- SUBSTITUTION OF COMPONENTS MAY IMPAIR INTRINSIC SAFETY.

APPROVAL DRAWING: **MOBREY**
DIMENSIONS IN MILLIMETRES
UNLESS OTHERWISE STATED
A3 DRAWING ON CAD

2	02/02/07	ST5290	DJS
ISS	DATE	CHANGE NOTE	NAME

PRINT MAY NOT BE TO SCALE STATED. IF IN DOUBT ABOUT DIMENSIONS THEN ASK.

TITLE: INTRINSICALLY SAFE CONTROL DRAWING

DRAWN	DATE	CHECKED	DRG. NO.
AST	11/08/05	DRH	71097/1167

Section 9 : Integral cable length for intrinsically safe systems

In calculating the permissible capacitance for an intrinsically safe system, the cable supplied with the equipment must be taken into consideration.

Integral electronics:

The value of C_i (378nF) must be increased by 0.25nF for each metre of integral cable fitted above 120m

Remote electronics:

The value of C_i (378nF) must be increased by 1.2nF for each metre of cable above 25m between the the sensor head and the remote electronics.

Integral units

For L ≤ 120m, C = 378nF

For L > 120m, C = 378 + 0.25(L - 120) nF

(L = length of integral cable in metres)

Remote units

For L ≤ 25m, C = 378nF

For L > 25m, C = 378 + 1.2(L - 25) nF

(L = length of integral cable in metres)

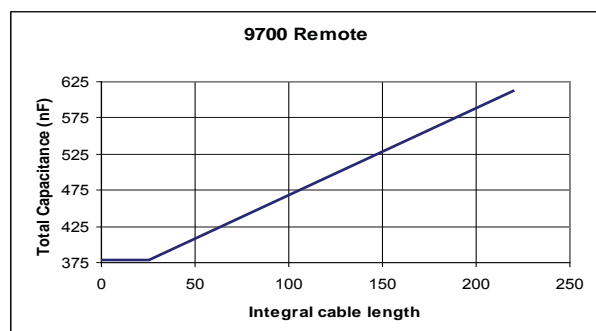
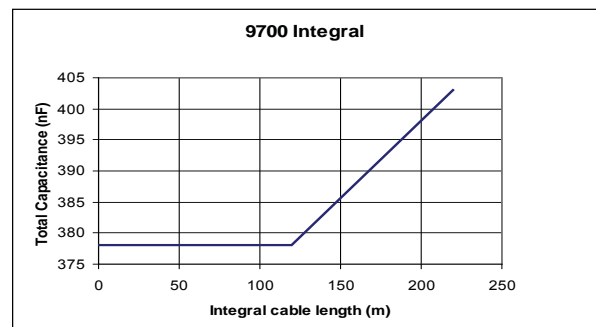

The Emerson logo is a trade mark and service mark of Emerson Electric Co.
Mobrey is a registered trademark of Mobrey Ltd.
All other marks are the property of their respective owners
We reserve the right to modify or improve the designs or specifications of product and services at any time without notice.

© 2011 Mobrey Ltd. All rights reserved.

International:

Emerson Process Management

Mobrey Measurement Division

158 Edinburgh Avenue,
Slough, Berks, SL1 4UE, UK

T +44 1753 756600

F +44 1753 823589

www.mobrey.com