

Mobrey Squing 2 Vibrating Fork Liquid Level Switch

- *Function virtually unaffected by flow, bubbles, turbulence, foam, vibration, solids content, coating, properties of the liquid, and product variations*
- *No need for calibration and requires minimum installation procedures*
- *Easy terminal access, polarity insensitive and short circuit protection*
- *No moving parts or crevices means virtually no maintenance*
- *Electronic, self-checking, and condition monitoring - Heartbeat LED gives status and health information*
- *Adjustable Switching Delay for turbulent/splashing applications*
- *Magnetic test point makes functional test easy*
- *Small in size and weight*
- *“Fast Drip” Fork Design gives quicker response time especially with viscous liquids*
- *Explosion-proof/Flameproof and Intrinsically Safe options*
- *SIL 2 of IEC 61508*



Contents

Reliable Performance...In Challenging Applications	page 2
Mobrey Squing 2 Vibrating Fork Liquid Level Switch	page 4
Specifications	page 7
Product Certifications	page 9
Dimensional Drawings.	page 11

Reliable Performance...In Challenging Applications



Threaded Process Connection



Flanged Process Connection



Adjustable Switching Delay



'Fast Drip' Forks

MEASUREMENT PRINCIPLE

The Mobrey Squing 2 is designed using the principle of a tuning fork. A piezo-electric crystal oscillates the forks at their natural frequency. Changes to this frequency are continuously monitored. The frequency of the vibrating fork sensor changes depending on the medium in which it is immersed. The denser the liquid, the lower the frequency.

When used as a **low level alarm**, the liquid in the tank or pipe drains down past the fork, causing a change of natural frequency that is detected by the electronics and switches the output state.

When the Squing 2 is used as a **high level alarm**, the liquid rises in the tank or pipe, making contact with the fork which then causes the output state to switch.

KEY FEATURES AND BENEFITS

- Virtually unaffected by turbulence, foam, vibration, solids content, coating, or liquid properties
- The Squing 2 is designed for operation in temperatures from -40 to 302 °F (-40 to 150 °C)
- Electronic self-checking and condition monitoring. The 'heartbeat' LED gives status and health information on the Squing 2
- Adjustable switching delay prevents false switching in turbulent or splashing applications
- 'Fast Drip' fork design gives quicker response time, especially with viscous liquids
- Rapid wet-to-dry time for highly responsive switching
- Fork shape is optimized for hand polishing to meet hygienic requirements
- No moving parts or crevices for virtually no maintenance

Product Data Sheet

00813-0100-4030, Rev FA
September 2011

Mobrey Squing 2

Fit and Forget

- Once installed, the Squing 2 is ready to go. It needs no calibration and requires minimum installation
- The 'heartbeat' LED gives an instant visual indication that the unit is operational
- Functional testing of the instrument and system is easy with a magnetic test point
- You can install, and forget it

Superior Performance

- The Squing 2 is a popular choice for high and low level alarm and pump control duties for its simplicity, ease of use, and reliability
- Functionality is virtually unaffected by flow, turbulence, bubbles, foam, or vibration
- The 'Fast Drip' design allows the liquid to be quickly drawn away from the fork tip, making the Squing 2 quicker and more responsive in high density or viscous liquid applications
- With a user-selectable time delay feature, the risk of false switching is minimized in turbulent or splashing applications

APPLICATIONS

- Overfill protection
- High and low level alarms
- Pump control or limit detection
- Run dry or pump protection
- Hygienic applications

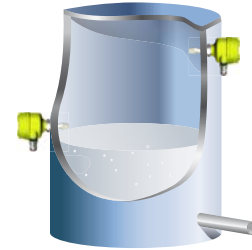

High And Low Level Alarm

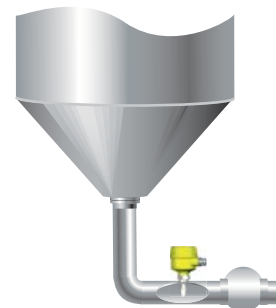

Pipe Installation
(Pump Protection)

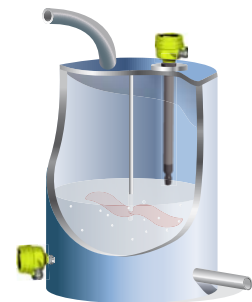

Pump Control / Limit Detection

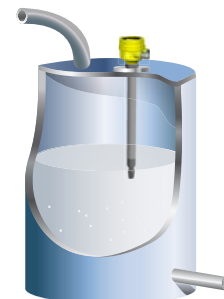

Hygienic Applications

Mobrey Squing 2

Mobrey Squing 2 Vibrating Fork Liquid Level Switch



Mobrey Squing 2
Level Switches

Mobrey Squing 2 capabilities include:

- Ideal for almost all liquid applications
- Wide choice of materials, process connections, and switching mechanisms configurable for your application
- Electronic, self-checking, and condition monitoring
- User-adjustable mode selection and time delay switch
- SIL2 suitable

Additional Information

Spares and Accessories: page 6
Specifications: page 7

Certifications: page 9
Dimensions: page 11

TABLE 1. Squing 2 Ordering Information

Model	Product Description
T	Sqing 2 Vibrating Fork Liquid Level Switch / -40...302 °F (-40...150 °C)
Materials of Construction (Process Connection and Fork)	
C ⁽¹⁾	Alloy C (UNS N10002), Alloy C-276 (UNS N10276), Solid
D	316L Stainless Steel (1.4404)
E	316L Stainless Steel 3.1 Certs (1.4404)
F ⁽²⁾	ECTFE/PFA copolymer, coated 316L Stainless Steel (1.4404)
G	ECTFE/PFA copolymer, coated 316L Stainless Steel 3.1 Certs (1.4404)
Process Connection Size	
1	1 in.
2	2 in. / DN50 / 51 mm
3	3 in. / DN80
4	4 in. / DN100
5	3/4 in.
6	1 1/2 / DN40 / 38 mm
7	DN65
8	A Flange
9	G Flange
Process Connection Fitting	
A	BSPT (R)
B	BSPP (G)
D	NPT
G	ASME B16.5 Class 150 Raised Face (RF) flange
H	ASME B16.5 Class 300 Raised Face (RF) flange
J	ASME B16.5 Class 600 Raised Face (RF) Flange
K	EN1092 PN 10/16 flange
L	EN1092 PN 25/40 flange
M	EN1092 PN 63 flange
N	EN1092 PN 100 flange
P	BSPP Hygienic fitting
Q	Mobrey A or G flange
R	Tri-Clover clamp
S	SMS hygienic fitting
T	Tuchenhagen
V	DIN 11851

Product Data Sheet

00813-0100-4030, Rev FA
September 2011

Mobrey Squing 2

TABLE 1. Squing 2 Ordering Information

Electronic Type	
S	Direct load switching (2-wire) 20 to 264 Vac 50/60Hz, 20 to 60 Vdc
B	PNP/PLC low voltage (3-wire) 20 to 60 Vdc
R	Relay (SPCO)
C ⁽³⁾	IS NAMUR (Ex ia)
Surface Finish	
1	Standard surface finish
2 ⁽⁴⁾	Hand polished (Ra < 0.4 µm)
Product Certifications	
NA	Standard (no approvals), M20 conduits, glass-filled nylon
ND	Standard (no approvals), 1/2-in. NPT conduits, glass-filled nylon
GY	FM and CSA (Unclassified, safe area), 3/4-in. conduits, aluminium
GT	FM and CSA (Unclassified, safe area), 3/4-in. conduits, 316 stainless steel
AA ⁽⁵⁾	ATEX and FM (IS), M20 conduits, glass-filled nylon
AD ⁽⁵⁾	ATEX and FM (IS), 1/2-in. NPT conduits, glass-filled nylon
CA ⁽⁵⁾	CSA (IS) and Non Incendive, M20 conduits, glass-filled nylon
CD ⁽⁵⁾	CSA (IS) and Non Incendive, 1/2-in. NPT conduits, glass-filled nylon
HA ⁽⁵⁾	IECEX (IS), M20 conduits, glass-filled nylon
HD ⁽⁵⁾	IECEX (IS), 1/2-in. NPT conduits, glass-filled nylon
EX ⁽⁶⁾	ATEX (Exd), M20 conduits, aluminium
ES ⁽⁶⁾	ATEX (Exd), M20 conduits, 316 stainless steel
FY ⁽⁶⁾	FM (Exd), 3/4-in. conduits, aluminium
FT ⁽⁶⁾	FM (Exd), 3/4-in. conduits, 316 stainless steel
DY ⁽⁶⁾	CSA (Exd), 3/4-in. conduits, aluminium
DT ⁽⁶⁾	CSA (Exd), 3/4-in. conduits, 316 stainless steel
JX ⁽⁶⁾	IECEX (Exd), M20 conduits, aluminium
JS ⁽⁶⁾	IECEX (Exd), M20 conduits, 316 stainless steel
Fork Length	
A ⁽⁷⁾	Standard length 1.7-in. (44 mm)
H	Standard length flange 4.0-in. (102 mm)
B ⁽⁸⁾	Ext 5.9-in. (150 mm)
C ⁽⁸⁾	Ext 11.8-in. (300 mm)
D ⁽⁸⁾	Ext 19.7-in. (500 mm)
L ⁽⁹⁾	Semi-ext 3.9-in. (98 mm)
E ⁽¹⁰⁾	Extended, customer specified length in millimeters
OPTIONS	
Specific Extended Fork Length	
XXXX	Specific customer specified length in millimeters (only if fork length E is selected)
Typical Model Number: T D 1 A R 1 NA A	

(1) Only in conjunction with approval and housing AA, AD, CA, CD, HA, and HD.

(2) Only in conjunction with Process Connection Fittings A and D.

(3) Conforms to SIL 2 of IEC 61508 as a Type B safety related subsystem when ordered as T***C*A**, T***C*C**, T***C*H** and configured as a high level alarm in conjunction with a Namur barrier.

(4) Only in conjunction with Process Connection Fittings P, R, S, V, or T.

(5) Only in conjunction with Electronic Type C.

(6) Not in conjunction with Electronic Type C. Not available with Fork Length L.

(7) Not available with flanged models. For flanged models, use Fork Length H.

(8) Not available with Process Connection Fitting R. Extended lengths for this must be ordered as T**R****E****.

(9) Only available with Materials of Construction codes D and E and Process Connection Size and Fittings 1A, 1B and 1D.

(10) ECTFE/PFA coating is available up to 1000 mm maximum. ECTFE/PFA coating is not available on threaded process connection options.

Mobrey Squing 2

Spare Parts and Accessories

TABLE 2. Spare Parts and Accessories

★The Standard offering represents the most common options. The starred options (★) should be selected for best delivery.
The Expanded offering is subject to additional delivery lead time.

Spares and Accessories	
SK331	Seal for 1-in. BSPP (G1A). Material: Non-asbestos BS7531 grade X carbon fiber with rubber binder
SK267	Hygienic adaptor boss 1-in. BSPP. Material: 316 Stainless fitting. FPM/FKM O-ring
SK266	2-in. (51 mm) Tri-clamp kit (vessel fitting, clamp ring, and seal). Material: 316 SST, NBR Nitrile
MSP-MMS	Telescopic test magnet
SK304 ⁽¹⁾	1 ¹ / ₂ -in. BSPP adjustable clamp gland for 1-in. extended lengths. Material: 316 Stainless steel, (Si) Silicone rubber seal
SK462 ⁽¹⁾	1 ¹ / ₂ -in. NPT adjustable clamp gland for 1-in. extended lengths. Material: 316 Stainless steel, (Si) Silicone rubber seal
SK439 ⁽²⁾	Replacement Cassette: Direct load switching (2 Wire) (Red)
SK440 ⁽²⁾	Replacement Cassette: PNP/PLC cassette (Yellow)
SK441 ⁽²⁾⁽³⁾	Replacement Cassette: Intrinsically Safe cassette (Blue)
SK442 ⁽²⁾	Replacement Cassette: Relay output cassette (Green)
SK443 ⁽⁴⁾	Replacement Cassette: FM Direct load switching (2 Wire) (Red)
SK444 ⁽⁴⁾	Replacement Cassette: FM PNP/PLC cassette (Yellow)
SK445 ⁽⁴⁾	Replacement Cassette: FM Relay output cassette (Green)

(1) The adjustable clamp gland is not explosion-proof.

(2) Available for Housing codes A and D.

(3) I.S. cassettes can only be replaced with I.S. cassettes. Non-I.S. cassette types can be interchanged with other non-I.S. cassettes, but the new label must be fitted and the original part number transferred to the new label.

(4) Available for Housing codes X, Y, S, and T.

Specifications

Physical

Product

Mobrey Squing 2 Vibrating Fork Liquid Level Switch

Measuring principle

Vibrating Fork

Applications

Most liquids including coating liquids, aerated liquids, and slurries

Mechanical

Housing and Enclosure

Housing Code	A	D	X	Y	S	T
Housing Material	Nylon PA66 30%GF		Al alloy ASTM B85 A360.0		316C12 Stainless Steel	
Housing Paint	Not Applicable		Polyurethane Powder Coat		Not Applicable	
LED Window	PMMA		None		None	
Conduit Entry	M20	1/2-in. NPT	M20	3/4-in. NPT	M20	3/4-in. NPT
Ingress Protection	IP66/67 to EN60529		IP66/67 to EN60529, Type 4X		IP66/67 to EN60529, Type 4X	

Connections

See Process Connection Size on page 4

Extended Lengths

The maximum extended length is 118.1 in. (3000 mm) except for a hand-polished Squing 2 that is limited to 39.4 in. (1000 mm)

Process Material

316L Stainless Steel (1.4404),
Alloy C (UNS N10002) and Alloy C-276 (UNS N10276), or
ECTFE/PFA co-polymer coated 316L Stainless Steel (1.4404)

Hand polished to better than 0.4 µm option available for hygienic connections

Gasket material for 3/4-in. and 1-in. BSPP (G) is Non-asbestos BS7531 Grade X carbon fiber with rubber binder

Dimensional Drawings

See Dimensional Drawings on page 11

Performance

Hysteresis (water)

±0.039-in. (±1 mm) nominal

Switching Point (water)

0.5 in. (13 mm) from tip (vertical) / from edge (horizontal) of fork
(this will vary with different liquid densities)

Functional

Maximum Operating Pressure

The final rating depends on the selected process connection.

Threaded Connection

See Figure 1 for operating pressures.

NOTE:

Clamp glands SK304 and SK462 (page 6) limit the maximum pressure to 18.85 psig (1,3 bar g)

Hygienic Connection

435 psig (30 bar g)

Flanged Connection

See Figure 1 or Table 3 (whichever one is the lowest)

FIGURE 1. Process Pressure

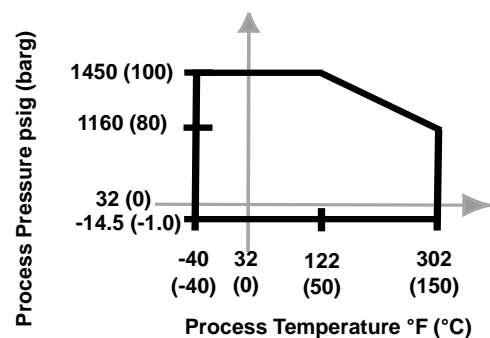

TABLE 3. Maximum Flange Pressure Rating

Standard	Class/Rating	SST Flanges
ASME B16.5	Class 150	275 psig ⁽¹⁾
ASME B16.5	Class 300	720 psig ⁽¹⁾
ASME B16.5	Class 600	1440 psig ⁽¹⁾
EN1092-1	PN 10/16	10/16 barg ⁽²⁾
EN1092-1	PN 25/40	25/40 barg ⁽²⁾
EN1092-1	PN 63	63 barg ⁽²⁾
EN1092-1	PN 100	100 barg ⁽²⁾

(1) At 100 °F (38 °C), the rating decreases with an increasing process temperature.

(2) At 122 °F (50 °C), the rating decreases with an increasing process temperature.

Minimum and Maximum Operating Temperature

See Figure 2 for operating temperatures.

NOTE:

Clamp glands SK304 and SK462 (page 6) limit the maximum temperature to 257 °F (125 °C).

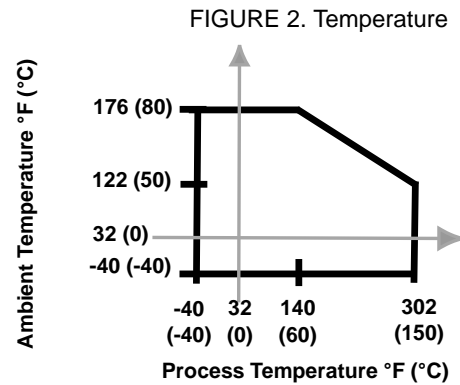

Liquid Density Range

Minimum 37.5 lb/ft³ (600 kg/m³)

Liquid Viscosity Range

0.2 to 10000 cP (centiPose)

Solids Content and Coating

Maximum recommended diameter of solid particles in the liquid is 0.2 in. (5 mm)

For coating product, avoid bridging of forks

Switching Delay

User selectable 0.3, 1, 3, 10, 30 seconds delay for dry-to-wet and wet-to-dry switching

CIP (Clean In Place) Cleaning

Withstands steam cleaning routines up to 302 °F (150 °C)

Electrical

Switching Mode

User selectable switching mode (Dry=on or Wet=on)

Protection

Polarity insensitive. Over-current, short-circuit and load-missing protection. Surge protection to IEC61326.

Terminal Connection (wire diameter)

Max. 0.1 in² (2,5 mm²). Note national regulations.

Conduit Plugs/Cable Gland

- Metal Ex d Housing: Conduit entries for explosion-proof areas are shipped with two brass conduit plugs
- Plastic housing with direct load, PNP/PLC and IS electronics are shipped with one PA66⁽¹⁾ cable gland and one blanking plug
- Plastic housing with relay electronics are shipped with two PA66⁽¹⁾ cable glands

(1) Cable diameter 0.2 to 0.3 in. (5 to 8 mm)

Grounding

The Squing 2 should always be grounded either through the terminals or using the external ground connection provided.

Electrical Connections

- Direct load switching (two-wire)

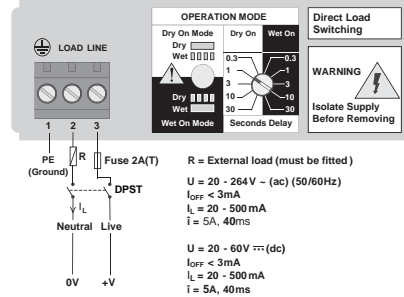

- Solid state PNP output for direct interface to PLC's (three wire)

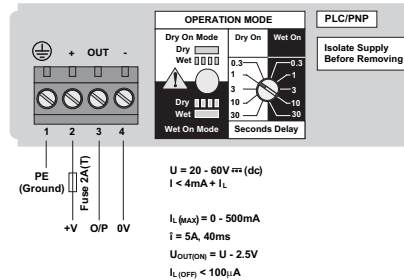

- SPCO single relay for voltage free contacts

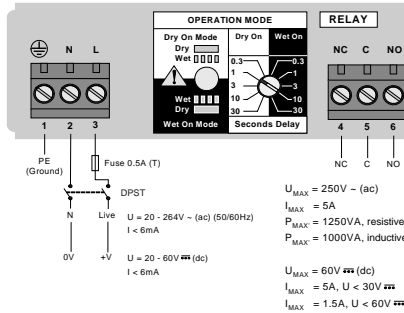

- Intrinsically Safe (IS) NAMUR to EN50227, IEC 60947-5-6

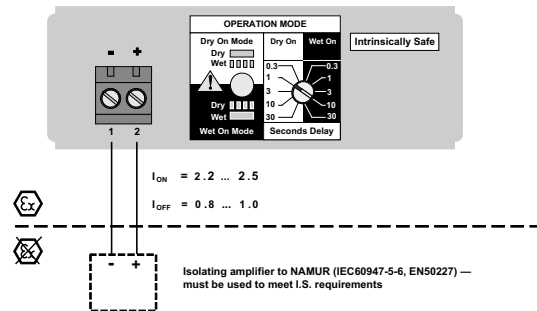

Product Certifications

ORDINARY LOCATION CERTIFICATION FOR FM

GT, GY The switch has been examined and tested to determine that the design meets basic electrical, mechanical, and fire protection requirements by FM, a nationally recognized testing laboratory (NRTL) as accredited by the Federal Occupational Safety and Health Administration (OSHA).

ORDINARY LOCATION CERTIFICATION FOR CSA

GT, GY The switch has been examined and tested to determine that the design meets basic electrical, mechanical, and fire protection requirements by CSA, a nationally recognized testing laboratory as accredited by the Standards Council of Canada (SCC).

EUROPEAN DIRECTIVE INFORMATION

A hard copy may be obtained by contacting your local sales office.

ATEX Directive (94/9/EC)

Complies with the ATEX Directive.

Pressure Equipment Directive (PED) (97/23/EC)

The Mobrey Squing 2 is outside the scope of PED Directive.

L.V. Directive

EN61010-1 Pollution degree 2, Category II (264V max), Pollution degree 2, Category III (150V max)

Electro Magnetic Compatibility (EMC) Directive

EN61326 Emissions to Class B.

Immunity to industrial location requirements.

Vibration Resistance

EN60721 level 3M6/4M6

CE-mark

Complies with applicable directives (EMC, ATEX, and LVD)

SIL Declaration of Conformity

The Squing 2 IS Namur Vibrating Fork Level Sensor (T***C*A**, T***C*C**, or T***C*H**) has demonstrated proven reliability. It is manufactured and supported in a manner suitable for applications up to SIL 2 of IEC 61508 as a Type B Safety Related Subsystem when configured⁽¹⁾ as a high level alarm in conjunction with a Namur Barrier.

HAZARDOUS LOCATIONS CERTIFICATIONS

North American Approvals

Factory Mutual (FM) Explosion-proof Approval

FY, FT Explosion-proof for Class I, Div. 1, Groups A, B, C, and D
Temperature Class:
T6 (T_{amb} -40 to 75 °C)
Enclosure: Type 4X

Factory Mutual (FM) Intrinsically Safe Approval

AA, AD Intrinsically Safe for Class I, Div. 1, Groups A, B, C, and D
Class I, Zone 0, AEx ia IIC
Temperature Code:
T5 (T_{amb} -40 to 80 °C, T_{proc} < 80 °C)
Control Drawing: 71097/1013
Ui=15 V, Ii=32 mA, Pi=0.1 W, Ci=211 nF, Li=0.06 mH

NOTE

A NAMUR isolating amplifier must be used for intrinsic safety.

Canadian Approvals

Canadian Standards Association (CSA) Explosion-proof Approvals

DY, DT Explosion-proof for Class I, Div. 1, Groups A, B, C, and D
Temperature Class:
T6 (T_{amb} -40 to 75 °C)
Enclosure: Type 4X

Canadian Standards Association (CSA) Intrinsically Safe Approval

CA, CD Intrinsically Safe for Class I, Div. 1, Groups A, B, C, and D
Class 1, Zone 0, Ex ia IIC
Temperature Code:
T5 (T_{amb} -40 to 80 °C, T_{proc} < 80 °C)
Control Drawing: 71097/1177
Ui=15 V, Ii=32 mA, Pi=0.1 W, Ci=211 nF, Li=0.06 mH

Canadian Standards Association (CSA) Non-Incendive Approval

CA, CD Non-Incendive for Class I, Div. 2, Groups A, B, C, and D
Temperature Code:
T5 (T_{amb} -40 to 80 °C, T_{proc} < 80 °C)
Control Drawing: 71097/1177
Ui=15 V, Ii=32 mA, Pi=0.1 W, Ci=211 nF, Li=0.06 mH

NOTE

A NAMUR isolating amplifier must be used for intrinsic safety.

(1) Refer to manual for IEC 61508 configuration details.

Mobrey Squing 2

Canadian Registration Number (CRN)

CRN 0F04227.2C

NOTE

The requirements of CRN are met when a Squing 2 CSA-approved vibrating fork level switch model is configured with 316L stainless steel (1.4404) wetted parts and either NPT threaded or 2-in. to 8-in. ASME B16.5 flanged process connections.

European Approvals

ATEX Flameproof Approval

EX, ES Certificate: Sira 01ATEX1263X
Flameproof and Dust:
ATEX Marking  II 1/2 G D
Ex d IIC T6 to T2
Ex tD A21 (T85°C to 265°C) IP6X

ATEX Intrinsically Safe Approval

AA, AD Certificate: Sira 01ATEX2121X
Intrinsic Safety and Dust:
ATEX Marking  II 1 G D
Ex ia IIC T5 to T2
Ex iaD 20 (T85 °C to 265 °C) IP6X
Ui=15 V, li=32 mA, Pi=0.1 W, Ci=12 nF, Li=0.06 mH

NOTE

A NAMUR isolating amplifier must be used for intrinsic safety.

International Approvals

International Electrotechnical Commission (IEC)

Flameproof Approval

JX, JS Certificate: IECEx SIR 06.0050X
Flameproof and Dust:
Zone 0/1
Ex d IIC T6 to T2
Ex tD A21 (T85 °C to 265 °C) IP6X

NOTE

A NAMUR isolating amplifier must be used for intrinsic safety.

International Electrotechnical Commission (IEC)

Intrinsically Safe Approval

HA, HD Certificate: IECEx SIR 06.0065X
Intrinsically Safe and Dust:
Ex ia IIC T5 to T2
Ex iaD 20 (T85 °C to 265 °C) IP6X
Ui=15 V, li=32 mA, Pi=0.1 W, Ci=12 nF, Li=0.06 mH

NOTE

A NAMUR isolating amplifier must be used for intrinsic safety.

Dimensional Drawings

Threaded Mounting

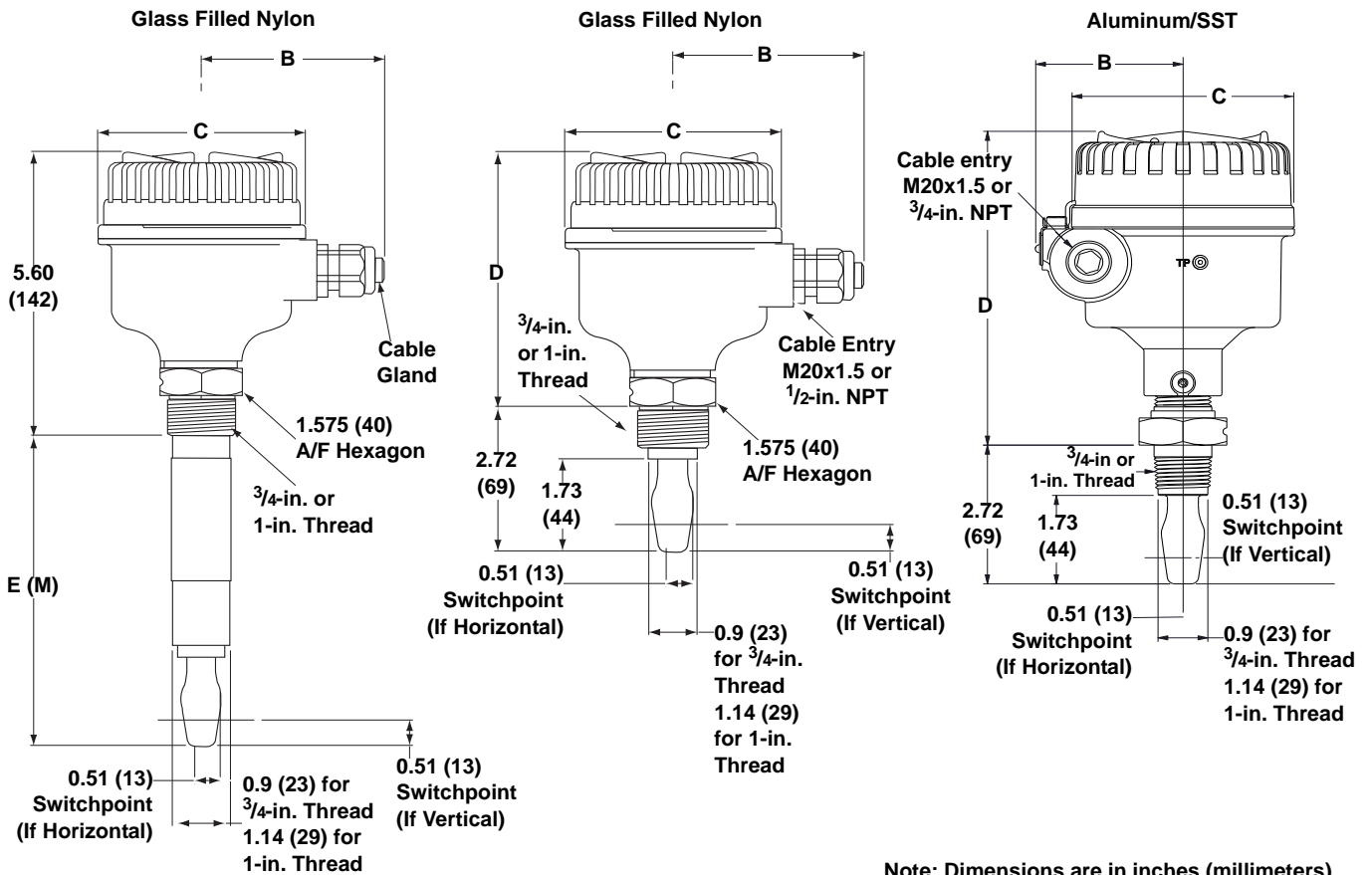

Thread	Standard Length Model Code A	Minimum Length Model Code E (M)	Maximum Length Model Code E (M)
3/4 in.	1.73 (44)	3.74 (95)	118.11 (3000)
1 in.	1.73 (44)	3.70 (94)	118.11 (3000)

Material	B	C	D
Glass Nylon	3.52 (90)	4.02 (102)	4.72 (120)
Aluminum	2.68 (68)	4.02 (102)	6.14 (156)
Stainless Steel	2.76 (70)	4.13 (105)	6.30 (160)

Mobrey Squing 2

Flange Mounting

(Glass filled nylon housing shown)

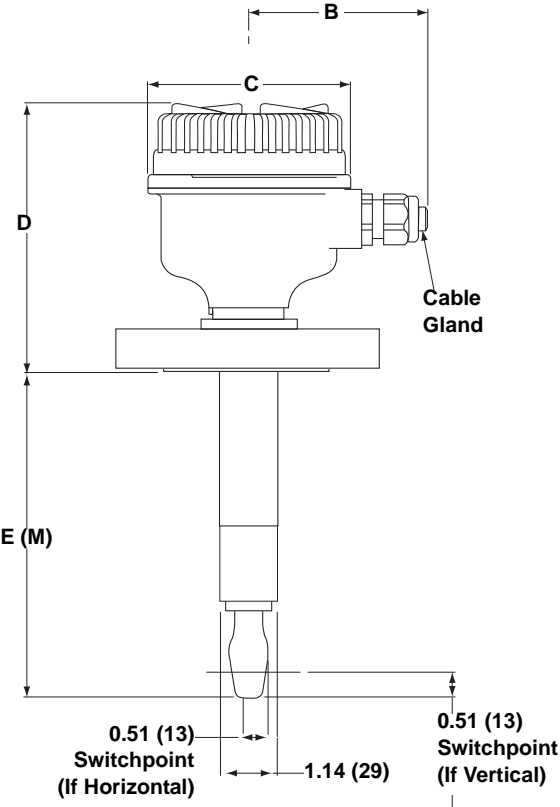

Note: Dimensions are in inches (millimeters)

Material	Standard Length Model Code H	Minimum Length Model Code E (M)	Maximum Length Model Code E (M)
Stainless Steel	4 (102)	3.50 (89)	118.11 (3000)
ECTFE/PFA co-polymer coated	4 (102)	3.50 (89)	39.37 (1000)

Material	B	C	D ⁽¹⁾
Glass Nylon	3.52 (90)	4.02 (102)	6.30 (160)
Aluminum	2.68 (68)	4.02 (102)	6.14 (156)
Stainless Steel	2.76 (70)	4.13 (105)	7.87 (200)

(1) Varies with flange rating and thickness. "D" is the nominal maximum thickness and allows a flange up to 1.77 in. (45 mm) thick. This equates to a 4-in. ASME B16.5 Class 600 Raised Face flange.

Hygienic Fitting

(Glass filled nylon housing shown)

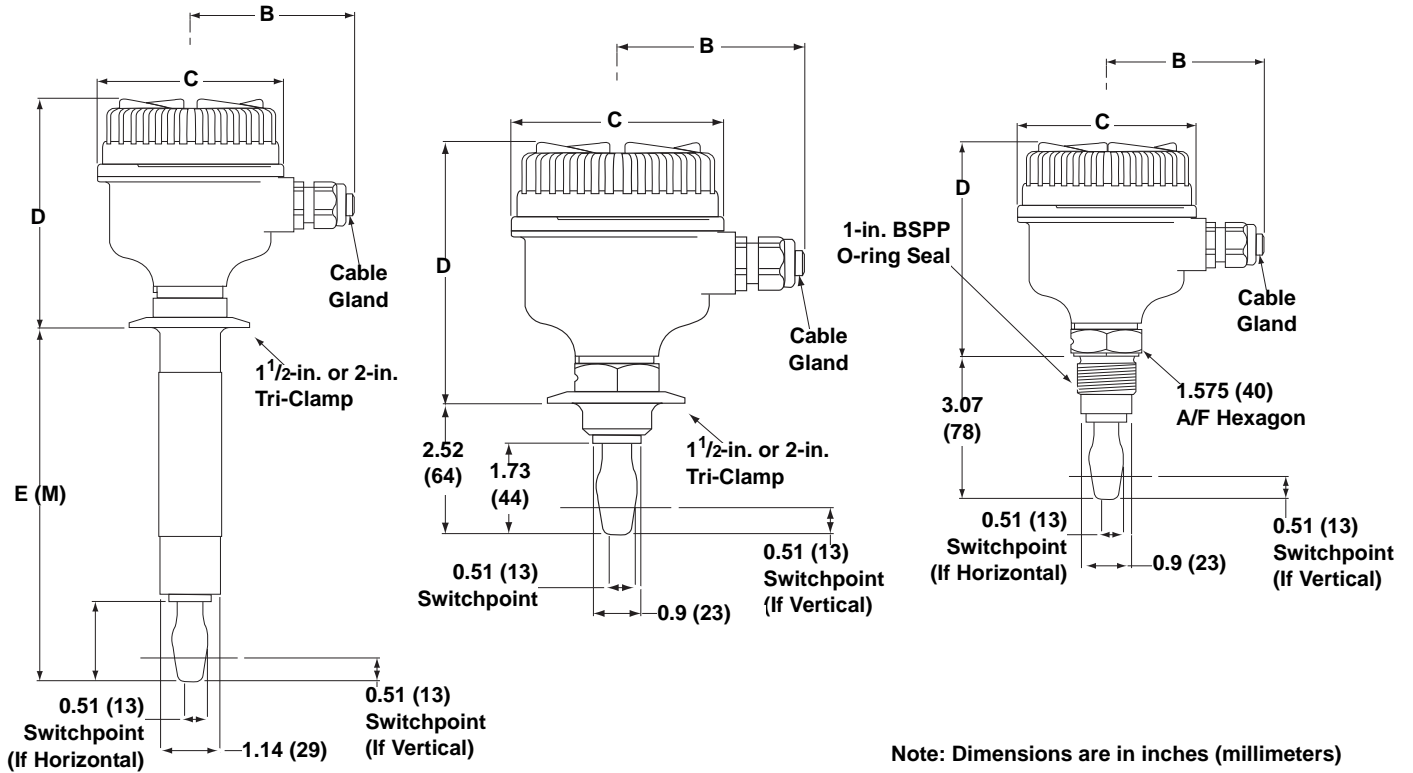

Connection	Standard Length Model Code A	Minimum Length Model Code E (M)	Maximum Length Model Code E (M)
Tri-Clamp	1.7 (44)	4.13 (105)	118.11 (3000)
O-ring Seal (1-in. BSPP)	1.7 (44)	Not Applicable	Not Applicable

Material	B	C	D
Glass Nylon	3.52 (90)	4.02 (102)	4.96 (126)
Aluminum	2.68 (68)	4.02 (102)	6.14 (156)
Stainless Steel	2.76 (70)	4.13 (105)	6.54 (166)

Mobrey Squing 2

Mobrey Squing 2

Mobrey Level Solutions

Emerson provides a wide range of Mobrey products for level measurement applications.

POINT LEVEL DETECTION

Vibrating Fork Liquid Level Switches

For high and low alarms, overflow protection, pump control, including wide pressure and temperature requirements, and hygienic applications. Flexible mounting. Immune to changing process conditions and suitable for most liquids.

- Mobrey Mini-Squing (Compact)
- Mobrey Squing 2 (Full-featured)

Ultrasonic Gap Sensor Liquid Level Switches

For use in non-hazardous industrial processes to detect high or low liquid levels and liquid interface. Immune to changing density, and wide dielectric and pH variations. Suitable for use in most clean and non-aerated liquids, with options for sludges and slurries.

Float and Displacer Liquid Level Switches

Mobrey electromechanical float and displacer level switches are ideal for alarm and pump control duties, especially in critical applications or hazardous areas.

- Mobrey Horizontal Level Switches
- Mobrey Vertical Level Switches

Chambers are available for external mounting of these level switches on process vessels.

Dry Products Level Switches

For high and low level alarms. Including threaded mounting connections, extended lengths, high temperature capability, and multiple detection techniques. Suitable for a wide variety of powders, granules, and free flowing solids with wide variations in bulk densities.

- Mobrey VLS Series – Vibrating Rod Level Switch
- Mobrey PLS Series – Paddle Level Switch
- Mobrey CLS Series – Capacitance Level Switch

CONTINUOUS MEASUREMENT

Ultrasonic Continuous Level Transmitters and Controllers

Top mounted, non-contacting for simple tank and open-air process level measurements. Unaffected by fluid properties such as density, viscosity, dirty coating, and corrosiveness. Intrinsically Safe versions are available for operating in hazardous areas.

- Mobrey MSP Series Ultrasonic Level and Flow Transmitters
- Mobrey MCU900 Series Universal Controllers

Ultrasonic Sludge Density Blanket Monitoring and Control

Ultrasonic in-line pipe or tank mounted sensors for sludge density measurement and control, and top mounted ultrasonic sensors for continuous measurement of sludge blanket level in Industrial and Municipal effluent treatment processes.

- Mobrey MSM400 – Sludge Density Monitor
- Mobrey MSL600 – Sludge Blanket Level Monitor

Displacer Continuous Level Measurement

Top mounted in a vessel or externally mounted in a vertical chamber. For use in hazardous areas.

- Mobrey MLT100 – Displacer Level Transmitter

Hydrostatic Continuous Level Transmitter

For level measurements in non-pressurized tanks where in-tank problems such as foaming, vapor layers, and temperature gradients prohibit the use of other instrumentation.

- Mobrey 9700 Series hydrostatic electronic level transmitters

SPECIALIZED CONDUCTIVITY

Conductivity Water and Steam Interface Monitoring

Steam/water interface level gauges using specialized, high performance conductivity probes in external columns and manifolds, ideal for steam plants where reliable and redundant indication of boiler water level and turbine protection is critical.

- Hydratect 2462 – Water/Steam detection Systems
- Hydrastep 2468 – Water/Steam Monitoring Systems

The Emerson logo is a trademark and service mark of Emerson Electric Co.

Rosemount is a registered trademark of Rosemount Inc.

Mobrey is a registered trademark of Mobrey Ltd.

All other marks are the property of their respective owners.

Standard Terms and Conditions of Sale can be found at www.rosemount.com/terms_of_sale

© 2011 Mobrey Ltd. All rights reserved.

**Emerson Process Management
Mobrey Measurement**
158 Edinburgh Avenue
Slough, Berks, SL1 4UE, UK
Tel +44 (0)1753 756600
Fax +44 (0)1753 823589
www.mobrey.com

**Emerson Process Management
Rosemount Measurement**
8200 Market Boulevard
Chanhassen MN 55317 USA
Tel (USA) 1 800 999 9307
Tel (International) +1 952 906 8888
Fax +1 952 906 8889