

Micro Motion® R-Series Coriolis Flow Sensors



Safety and approval information

This Micro Motion product complies with all applicable European directives when properly installed in accordance with the instructions in this manual. Refer to the EC declaration of conformity for directives that apply to this product. The EC declaration of conformity, with all applicable European directives, and the complete ATEX Installation Drawings and Instructions are available on the internet at www.micromotion.com/atex or through your local Micro Motion support center.

Information affixed to equipment that complies with the Pressure Equipment Directive can be found on the internet at www.micromotion.com/documentation.

For hazardous installations in Europe, refer to standard EN 60079-14 if national standards do not apply.

Other information

Full product specifications can be found in the product data sheet. Troubleshooting information can be found in the transmitter configuration manual. Product data sheets and manuals are available from the Micro Motion web site at www.micromotion.com/documentation.

Return policy

Micro Motion procedures must be followed when returning equipment. These procedures ensure legal compliance with government transportation agencies and help provide a safe working environment for Micro Motion employees. Failure to follow Micro Motion procedures will result in your equipment being refused delivery.

Information on return procedures and forms is available on our web support system at www.micromotion.com, or by phoning the Micro Motion Customer Service department.

Micro Motion customer service

Location		Telephone number
U.S.A.		800-522-MASS (800-522-6277) (toll free)
Canada and Latin America		+1 303-527-5200 (U.S.A.)
Asia	Japan	3 5769-6803
	All other locations	+65 6777-8211 (Singapore)
Europe	U.K.	0870 240 1978 (toll-free)
	All other locations	+31 (0) 318 495 555 (The Netherlands)
Customers outside the U.S.A. can also send an email to flow.support@emerson.com .		

Contents

- Chapter 1 Planning1**
 - 1.1 Installation checklist1
 - 1.2 Best practices2
 - 1.3 Environmental limits2
- Chapter 2 Mounting4**
 - 2.1 Mount the sensor4
- Chapter 3 Wiring5**
 - 3.1 Options for wiring5
 - 3.2 Connect 4-wire cable5
- Chapter 4 Grounding9**

1 Planning

Topics covered in this chapter:

- [Installation checklist](#)
- [Best practices](#)
- [Environmental limits](#)

1.1 Installation checklist

- Make sure that the hazardous area specified on the sensor approval tag is suitable for the environment in which the sensor is installed.
- Verify that the local ambient and process temperatures are within the limits of the sensor. See [Environmental limits](#).
- If your sensor has an integral transmitter, no wiring is required between the sensor and transmitter. Follow the wiring instructions in the transmitter installation manual for signal and power wiring.
- If your transmitter has remote-mounted electronics, follow the instructions in this manual for wiring between the sensor and the transmitter, and then follow the instructions in the transmitter installation manual for power and signal wiring.
- For the wiring between the sensor and the transmitter, consider maximum cable lengths (see [Table 1-1](#) and [Table 1-2](#)). The maximum distance between the sensor and transmitter depends on the cable type. For all types of wiring, Micro Motion recommends using Micro Motion cable.

Table 1-1: Maximum lengths for Micro Motion cable

Cable type	To transmitter	Maximum length
Micro Motion 4-wire	All 4-wire MVD transmitters	1000 ft (300 m)

Table 1-2: Maximum lengths for user-supplied 4-wire cable

Wire function	Wire size	Maximum length
Power (VDC)	22 AWG (0,35 mm ²)	300 ft (90 m)
	20 AWG (0,5 mm ²)	500 ft (150 m)
	18 AWG (0,8 mm ²)	1000 ft (300 m)
Signal (RS-485)	22 AWG (0,35 mm ²) or larger	1000 ft (300 m)

- For best performance, follow Micro Motion recommendations for sensor orientation (see [Table 1-3](#)). The sensor will work in any orientation as long as the flow tubes remain full of process fluid.

Table 1-3: Recommended sensor orientation

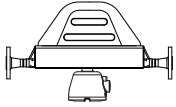
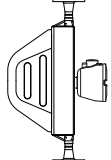
Liquids	
Gases	
Slurries	

- Install the sensor so that the flow direction arrow on the sensor matches the actual forward flow of the process.

1.2 Best practices

The following information can help you get the most from your sensor.

- There are no pipe run requirements for Micro Motion sensors. Straight runs of pipe upstream or downstream are unnecessary.
- If the sensor is installed in a vertical pipeline, liquids and slurries should flow upward through the sensor. Gases may flow upward or downward.
- Keep the sensor tubes full of process fluid.
- For halting flow through the sensor with a single valve, install the valve downstream from the sensor.
- Minimize bending and torsional stress on the meter. Do not use the meter to align misaligned piping.
- The sensor does not require external supports. The flanges will support the sensor in any orientation.

1.3 Environmental limits

See [Figure 1-1](#) for the ambient and process temperature limits of the sensor.

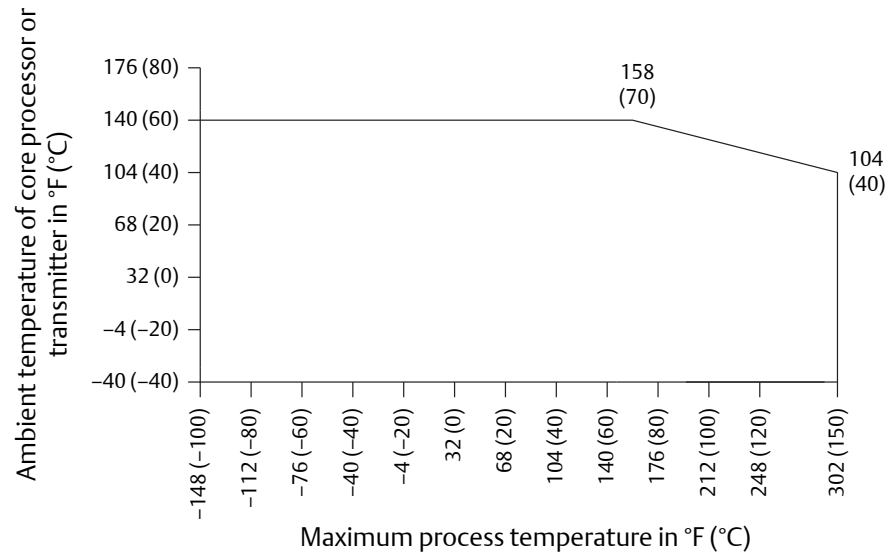
Figure 1-1: Environmental limits for R-Series sensors**Notes**

- When ambient temperature is below -40°F (-40°C), a core processor or transmitter must be heated to bring its local ambient temperature to between -40°F (-40°C) and $+140^{\circ}\text{F}$ ($+60^{\circ}\text{C}$). Long-term storage of electronics at ambient temperatures below -40°F (-40°C) is not recommended.
- Temperature limits may be further restricted by hazardous area approvals. Refer to the hazardous area approvals documentation shipped with the sensor or available from the Micro Motion web site (www.micromotion.com).
- The extended-electronics option allows the sensor case to be insulated without covering the transmitter or core processor, but does not affect temperature ratings.

2 Mounting

2.1 Mount the sensor

Use your common practices to minimize torque and bending load on process connections.

Tip

To reduce the risk of condensation or excessive moisture, the conduit opening should not point upward (if possible). The conduit opening of the core processor can be rotated freely to facilitate wiring.

Procedure

Mount the sensor in the pipeline (see [Figure 2-1](#)).

Figure 2-1: Mounting the sensor

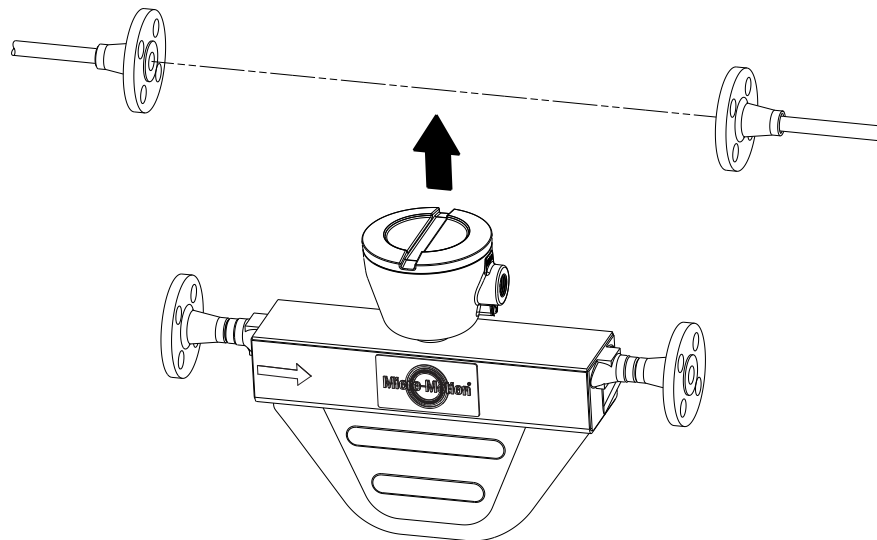
**Notes**

- Do not use the sensor to support the piping.
 - The sensor does not require external supports. The flanges will support the sensor in any orientation.
-

⚠ CAUTION!

Do not lift the sensor by the electronics. Lifting the sensor by the electronics can damage the device.

3 Wiring

Topics covered in this chapter:

- [Options for wiring](#)
- [Connect 4-wire cable](#)

3.1 Options for wiring

The wiring procedure you follow depends on which electronics option you have.

See [Table 3-1](#) for the wiring options for each sensor electronics option.

Table 3-1: Wiring procedures by electronics option

Electronics option	Wiring procedure
Integral transmitter	No wiring required between sensor and transmitter. See the transmitter installation manual for wiring the power and signal cable to the transmitter.
MVD™ Direct Connect™	No transmitter to wire. See the MVD Direct Connect manual for wiring the power and signal cable between the sensor and the direct host.
Core processor	See Connect 4-wire cable .

CAUTION!

Make sure the hazardous area specified on the sensor approval tag is suitable for the environment in which the sensor will be installed. Failure to comply with the requirements for intrinsic safety in a hazardous area could result in an explosion.

CAUTION!

Fully close and tighten all housing covers and conduit openings. Improperly sealed housings can expose electronics to moisture, which can cause measurement error or flowmeter failure. Inspect and grease all gaskets and O-rings.

3.2 Connect 4-wire cable

Step 1: Cable preparation

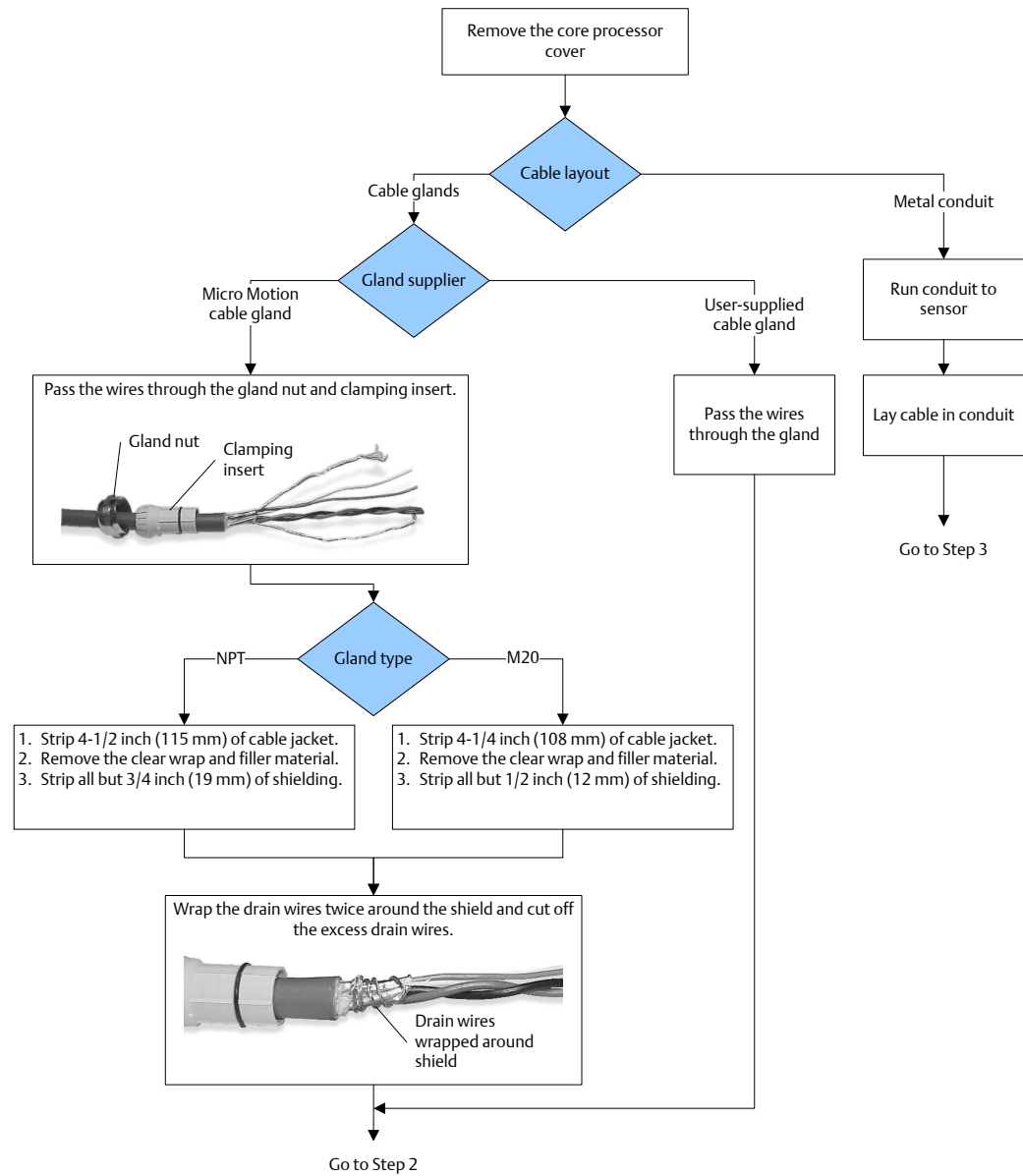

Step 2: Shield termination

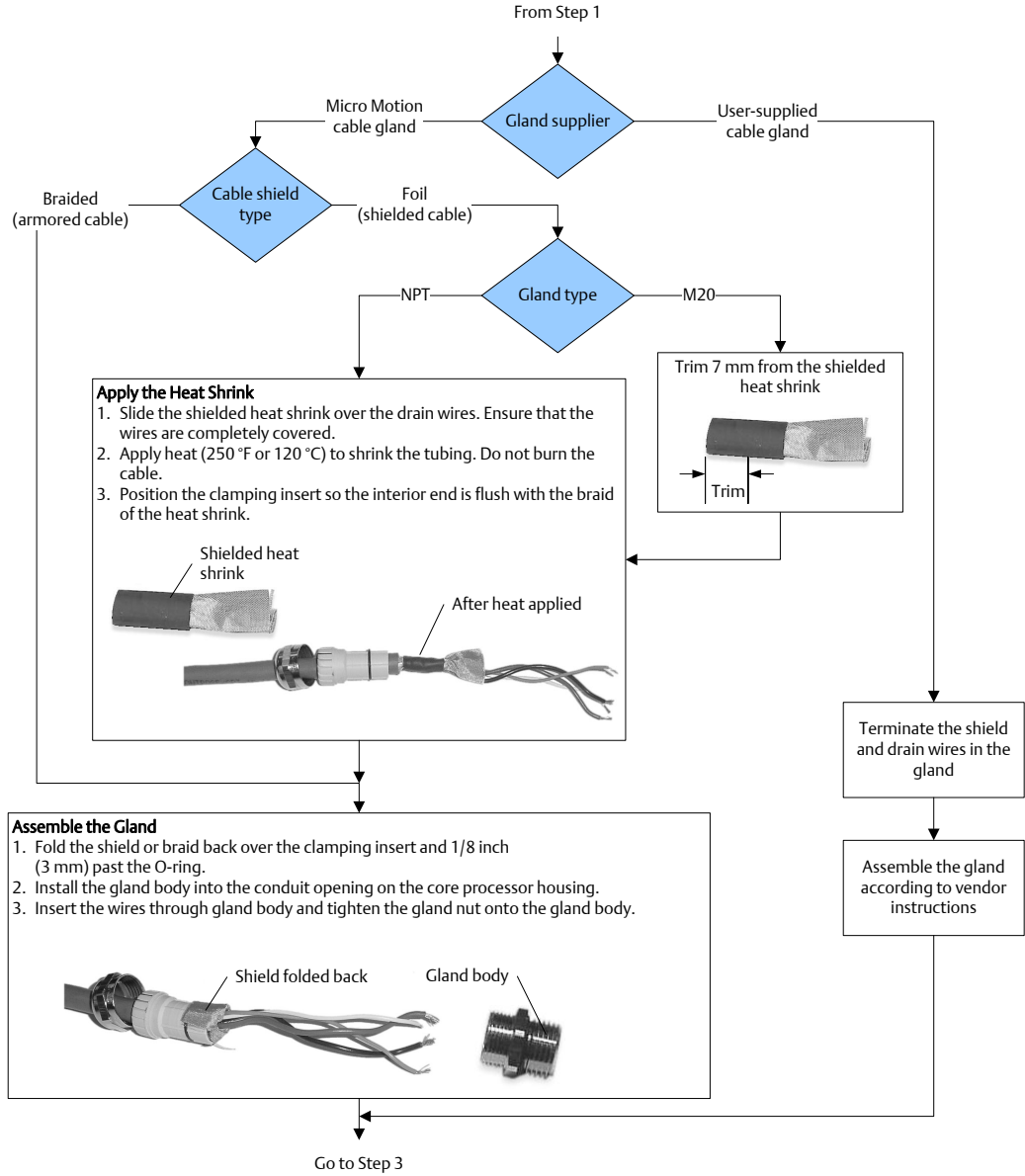

Step 3: Terminal connections

From Step 1 or 2

Connect the wires to the core processor terminals:
Red wire > Terminal 1 (Power supply +)
Black wire > Terminal 2 (Power supply -)
White wire > Terminal 3 (RS-485/A)
Green wire > Terminal 4 (RS-485/B)

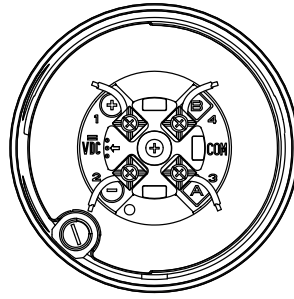

Reinstall and tighten the core processor cover

Connect the wires to the transmitter terminals
(see the transmitter manual)

4 Grounding

The sensor must be grounded according to the standards that are applicable at the site. The customer is responsible for knowing and complying with all applicable standards.

Prerequisites

Micro Motion suggests the following guides for grounding practices:

- In Europe, IEC 79-14 is applicable to most installations, in particular Sections 12.2.2.3 and 12.2.2.4.
- In the U.S.A. and Canada, ISA 12.06.01 Part 1 provides examples with associated applications and requirements.

If no external standards are applicable, follow these guidelines to ground the sensor:

- Use copper wire, 14 AWG (2,0 mm²) or larger wire size.
- Keep all ground leads as short as possible, less than 1 Ω impedance.
- Connect ground leads directly to earth, or follow plant standards.

CAUTION!

Ground the flowmeter to earth, or follow ground network requirements for the facility. Improper grounding can cause measurement error.

Procedure

Check the joints in the pipeline.

- If the joints in the pipeline are ground-bonded, the sensor is automatically grounded and no further action is necessary (unless required by local code).
- If the joints in the pipeline are not grounded, connect a ground wire to the grounding screw located on the sensor electronics.

Tip

The sensor electronics may be a transmitter, core processor, or junction box. The grounding screw may be internal or external.



20002514

Rev BA

2010

Micro Motion Inc. USA

Worldwide Headquarters
7070 Winchester Circle
Boulder, Colorado 80301
T +1 303-527-5200
T +1 800-522-6277
F +1 303-530-8459
www.micromotion.com

Micro Motion Europe

Emerson Process Management
Neonstraat 1
6718 WX Ede
The Netherlands
T +31 (0) 318 495 555
F +31 (0) 318 495 556
www.micromotion.nl

Micro Motion Asia

Emerson Process Management
1 Pandan Crescent
Singapore 128461
Republic of Singapore
T +65 6777-8211
F +65 6770-8003

Micro Motion United Kingdom

Emerson Process Management Limited
Horsfield Way
Bredbury Industrial Estate
Stockport SK6 2SU U.K.
T +44 0870 240 1978
F +44 0800 966 181

Micro Motion Japan

Emerson Process Management
1-2-5, Higashi Shinagawa
Shinagawa-ku
Tokyo 140-0002 Japan
T +81 3 5769-6803
F +81 3 5769-6844

©2010 Micro Motion, Inc. All rights reserved.

The Emerson logo is a trademark and service mark of Emerson Electric Co. Micro Motion, ELITE, ProLink, MVD and MVD Direct Connect marks are marks of one of the Emerson Process Management family of companies. All other marks are property of their respective owners.

