

Damcos Accumulator Rack

Stand Alone System

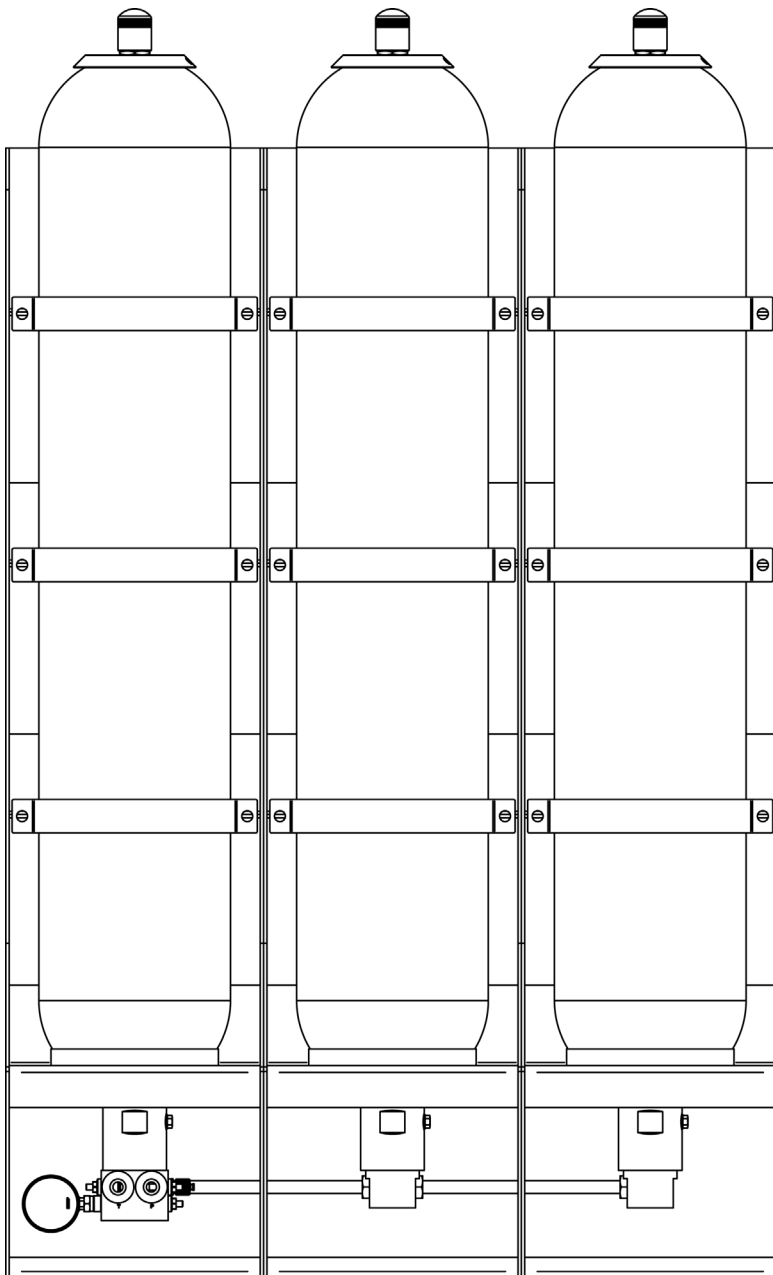

Description

Stand alone accumulator with stainless steel rack. The stand-alone accumulator rack contains one or more bladder accumulators, a connection block and a stainless steel rack. The accumulator is used to store energy by pressure and can therefore be used together with DAMCOS hydraulic valve remote control system. The stand alone accumulatorbank can be used for more purposes, the most common used are as following:

System-Service

System-service means that the accumulator is in function while the system is running. The system-service is used as a support to the power unit. It compensates for leakage in solenoid valves meaning less start/stop for the power unit. In cases where many valves and/or huge valves are operated at the same time, the accumulator can/will be used to compensate for pressure drop, by supplying oil into the system.

Installation

The accumulator-rack can be installed in more ways. It can be bolted either to the deck through the mounting holes in the bottom or to the wall trough the holes in the back. It can be assembled in groups, side by side, and/or back to back. All holes for fastening and assembly are with a diameter of 13 mm.

ESD

ESD (emergency shut down) means that, if the power unit for some reasons are not able to deliver oil pressure, the accumulator can be used to maintain enough system pressure to operate some important valves. Please note that this ESD function has a limited oil amount, which means that it is only possible to operate a certain amount of valves without recharging the oil pressure in the accumulator.

When more accumulators are used at the same system, they must be connected intermediately by tubing. All the tubing connection, at the accumulator-block, are made with ½" BSP female thread.

Hydraulic Diagrams

System Service

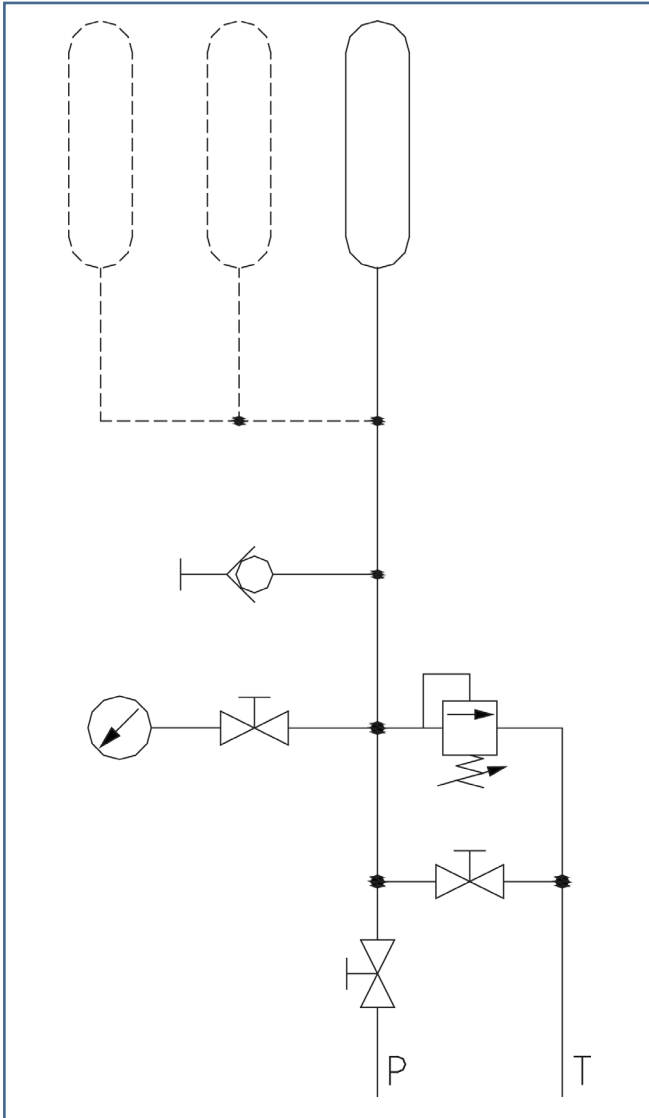

When accumulators are used for system-service the system contains 1 block. This block contains a bypass valve, a pressure relief valve, a manometer and a quick connection for external use. Systems with more accumulators only need one of these blocks. Extra accumulators are connected by tubing to the common block. The extra accumulators need accumulator nut (for the tube connection) instead of a block.

ESD (Emergency Shut Down)

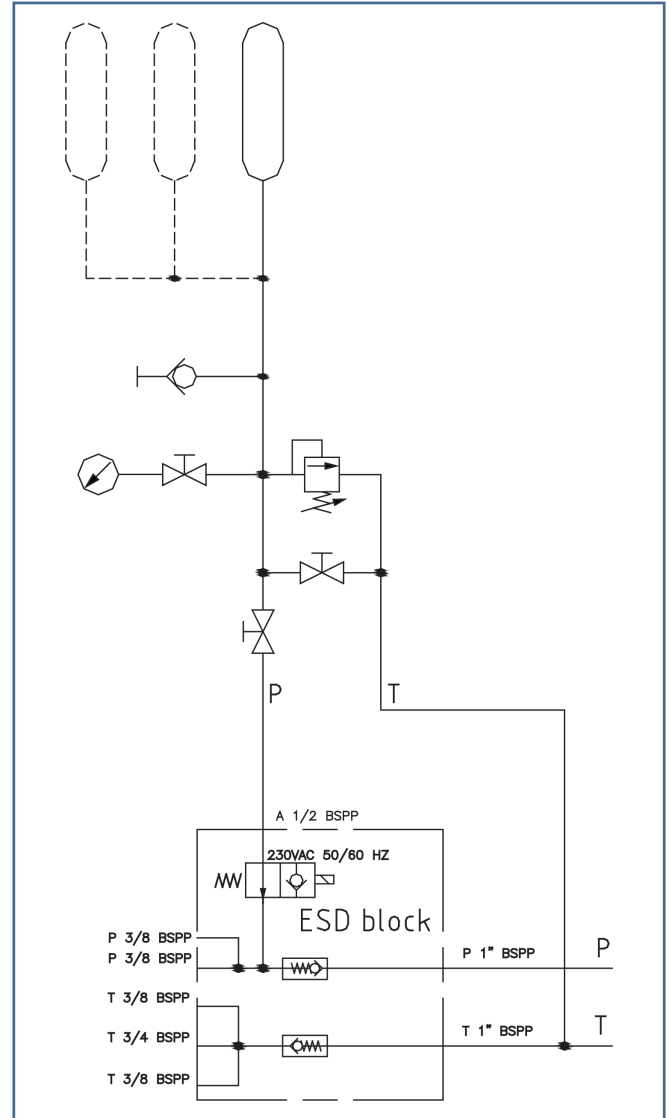

When accumulators are used for ESD, the system contains 2 blocks. One similar to the one used for system-service and one which is placed in the solenoid valve cabinet called ESD-block. The ESD-block contains 2 non-return valves and a solenoid valve. This solenoid valve controls when the stored pressure energy is to be used, for example in case of a power loss.

Technical Data

Working pressure	same as system (usually 135 bar)
Accumulator maximum pressure	330 bar
Connection block maximum pressure	250 bar
Weight (dry) 20l	80 kg
Weight (dry) 32l	125 kg
Nirtrogen charge pressure	Approx. 125 bar (0.9 x working pressure)

Materials

Accumulator	Carbon steel
Bladder	NBR
Rack	Stainless steel AISI 316
Rack edge-protection	NBR
Connection block	Brass
Fitting	Stainless steel AISI 316
Manometer	Stainless steel

ID-Number

Stainless steel rack	20L rack 165F3297 32L rack 165F3298	Main rack including edge protection and lifting eye for safe moving.
Accumulator block	165F2551	Backup block
ESD-block	165F2161	Cabinet block
Adapter kit		Adapter kit depending on configuration and requirements - contact Damcos for further information.
Accumulators	-	Depends on classification societies contact Damcos for further information.

Dimension

Reference	with 20L acc. (mm)	with 32L acc. (mm)
A	1032	1536
B	300	300
C	500	600
D	N/A	900
E	900	1300
F	N/A	800
G	800	1200

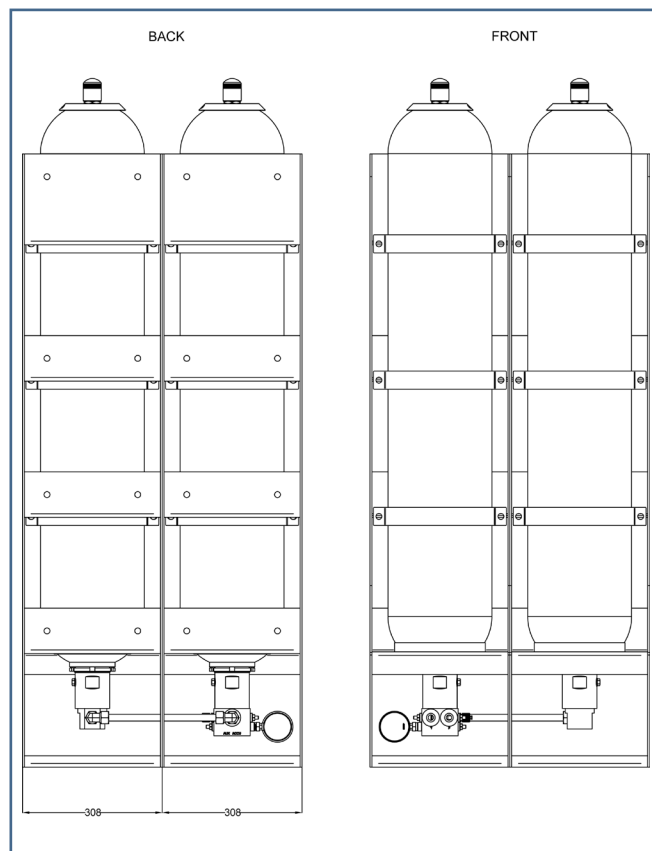
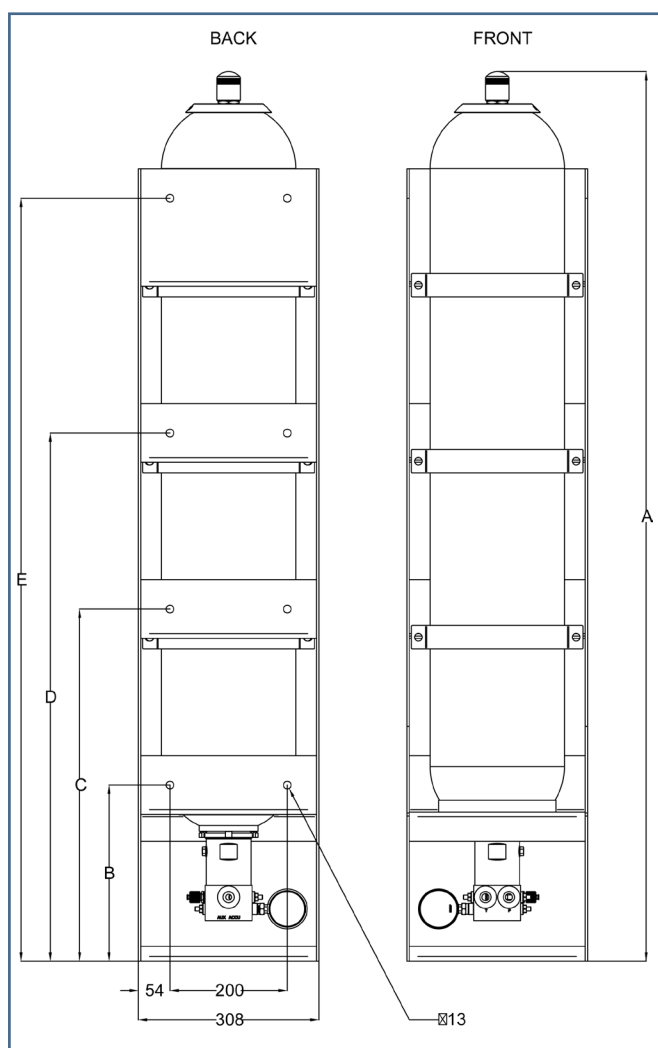

Note! The accumulator shown in this picture is of a 32L type.

Dimension

Back to back

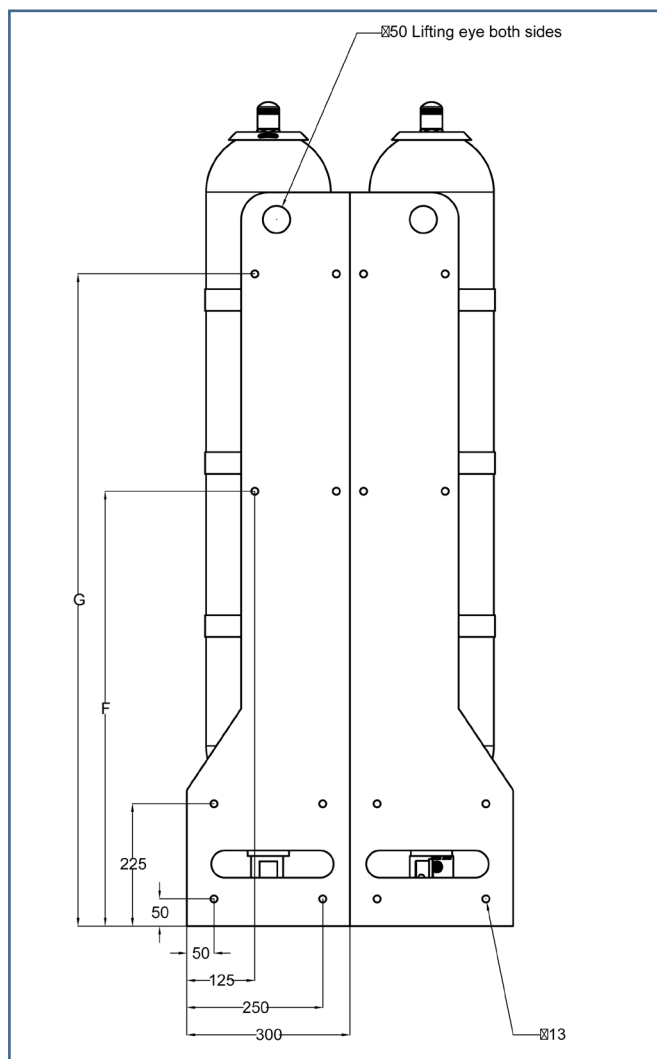

Bottom

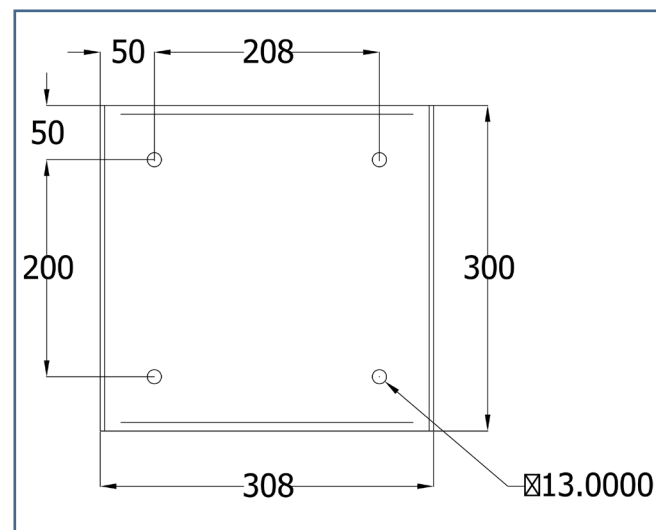

©2014 Emerson Process Management. All rights reserved.

The Emerson logo is a trademark and service mark of Emerson Electric Co. Rosemount and the Rosemount logotype are registered trademarks of Rosemount Inc. Damcos and the Damcos logotype are trademarks of Damcos A/S. Damcos A/S is a member of the Emerson Process Management family of companies. All other marks are the property of their respective owners.

Emerson Process Management

Damcos A/S
Aaderupvej 41
DK-4700 Naestved
T +45 5578 7200
F +45 5578 7272

www.EmersonProcess.com/mtm

The contents of this publication are presented for information purposes only, and while effort has been made to ensure their accuracy, they are not to be construed as warranties or guarantees, express or implied, regarding the products or services described herein or their use or applicability. All sales are governed by our terms and conditions, which are available on request. We reserve the right to modify or improve the designs or specifications of our products at any time without notice.

Damcos A/S accepts no responsibility for any errors that may appear in this publication.