

DeltaV™ SD Plus Controller

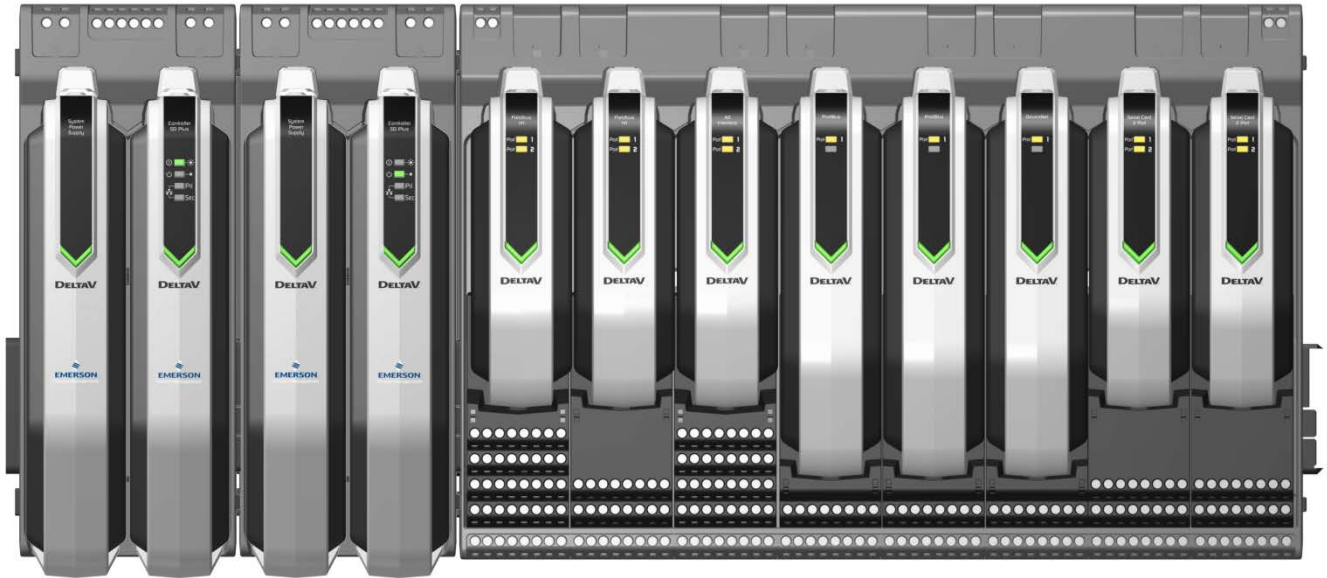

The DeltaV™ SD Plus Controller and the DeltaV I/O subsystem make rapid installation easy

- Scalable controllers
- Quick Assembly
- Easy to use
- Field Proven architecture
- Designed for Digital Marshalling
- Advanced Controls

Introduction

The DeltaV™ S-Series controllers provide communication and control functions and integrate field devices and the other nodes on the control network. The SX and SD Plus controllers provide a choice to match the controller capacity to the requirements of the process. They also provide new ease of use features that eliminate mounting screws and accelerate cabinet assembly.

Control strategies and system configurations created on earlier DeltaV systems can be used with this controller. The SD Plus Controller provides all the features and functions of the M-Series controllers with the added support for CHARM based Digital Marshalling.

The control languages executed in the controllers are described in the Control Software product data sheet.

Benefits

Scalable controllers. The SD Plus controller complements the SX controller by providing a smaller controller platform at a reduced price for those small to moderate applications:

- **Speed.** The SD Plus controller supports all the features you've come to expect from the DeltaV system: self-addressing, automatic I/O detection. All these features are designed to make your projects execute faster—*just plug and play!*
- **Redundant architecture.** The SD Plus controller supports 1:1 redundancy for increased availability. Redundant SD Plus controllers can be upgraded to SX controllers online—*robust!*
- **Late Changes.** You can easily upgrade an SD Plus controller to an SX to handle project scope changes late in the project. Simply replace the SD Plus with the SX and all existing configuration, documentation and hardware design remain the same —*forgiving.*

Quick Assembly. The S-Series hardware has been redesigned for speed of project execution. Carriers snap to standard DIN rails and controllers and S-series IO snap into position without the use of retaining screws.

Easy to use. Controllers are also easy to configure. Simply connect the SD Plus to the DeltaV network and Auto-Sense it from DeltaV Explorer. Add the controller and all its IO interfaces to the system database and all components are automatically addressed and communicating. There are no dip switches or jumpers to set.

- Control strategies are developed using IEC-61131 programming techniques: Function Blocks, Sequential Function Charts and Structured Text.
- Automatic diagnostic and event reporting with time stamps applied in the controller
- Set control execution to match process dynamics and controller scheduling adjusts automatically.
- Reference any parameter by its module name, regardless of its location in the system.
- Synchronized system clock for consistent time based event driven actions across the system.
- Online expandable IO carriers allow new cards to be added online, with autosense capability, for modular system growth

- Hardware redundancy is automatically detected with zero configuration effort.

Field Proven Architecture. The S-Series controllers are an evolution of DeltaV M-Series hardware. The new design delivers installation and robustness enhancement while still using the same processor and OS that has proven itself in the field. All S-series I/O cards run the latest software enhancements of corresponding M-Series I/O cards and deliver the same field proven, reliable operation.



The SD Plus Controller

Designed for Digital Marshalling. The S-Series controllers have highly distributable I/O capabilities with CHARMs based Electronic Marshalling. Electronic Marshalling I/O can be mounted anywhere, facilitating system design and expansion while reducing overall system footprint over traditional marshalled I/O Subsystems.

Advanced Controls. The SD Plus controller supports all the advanced control features that are expected in a world class Digital Control System:

- Batch Software
- Model Predictive Control
- Neural Networks

Product Description

The SD Plus controller executes control logic based on the process signals derived from the I/O subsystem and provides communication to the rest of the DeltaV control system for operator interaction and data collection.

Each controller node can be installed as a simplex or redundant node. Redundancy is provided by adding a second controller and power supply mounted adjacent to the primary controller. The controllers are connected to the I/O carriers, which are mounted to the right of the controller carriers. Up to 8 carriers with 8 cards each can be connected to the local bus I/O, for a total of 64 traditional I/O cards. In addition to the 8 local I/O carriers, each controller can communicate with an additional 16 Remote I/O units hosting traditional card based I/O.

In addition to traditional I/O cards, the local bus supports fieldbus technologies, including FOUNDATION fieldbus, Profibus DP, DeviceNet and AS-I protocols. The I/O subsystem also supports Serial interface cards as well as the Ethernet I/O interface. These various I/O products provide a wide range of interfaces to meet the needs of your control application.

The SD Plus also supports CHARMs and WirelessHART I/O cards. The CHARM I/O Card (CIOC) connects via the redundant Ethernet ports of the controller and provides a highly distributed and flexible I/O solution called Electronic Marshalling. Up to 16 CIOC's can communicate with one controller, each providing up to 96 individually configurable signal types. Note: To ensure the overall Performance of the SD Plus Controller, the free Time and free

Memory min. levels have to be maintained when CIOC's are involved in the communication. Based on the latest V11.3.1 Software, a maximum of 6 CIOC's communicating to one Controller should be considered. The latest DeltaV Software version will be available starting Nov. 2011. Please use the Load Estimator Tool on the DeltaV DVD#2 to ensure proper Load of the Controller.

The WirelessHART I/O card (WIOC) provides redundant communication for up to 100 WirelessHART devices, providing high availability and reliability of wireless data. Up to 16 Wireless HART I/O cards can communicate to a single controller.

Control modules are automatically scheduled by the controller, based on their assigned scan rates. This allows each control function to be optimized based on the process dynamics. Modules scan times can be set as fast as 100 ms, and as slow as 60 seconds. The number of control modules that can be assigned to a controller depends on the complexity and scan rate of each module, and the available CPU and memory. The SD Plus controller should be used for small to medium applications with a maximum of 750 individual I/O signals.

The SD Plus controller is designed for harsh environments and is rated for G3 corrosive environments, with an operating temperature range from -40 to 70 °C. It is ideally suited for remote installation, close to the process equipment. For more traditional installations with central marshalling cabinets, CHARM I/O Cards can be mounted in standard I/O cabinets providing Electronic Marshalling. CHARM I/O Cards can also be used for highly distributed I/O applications.

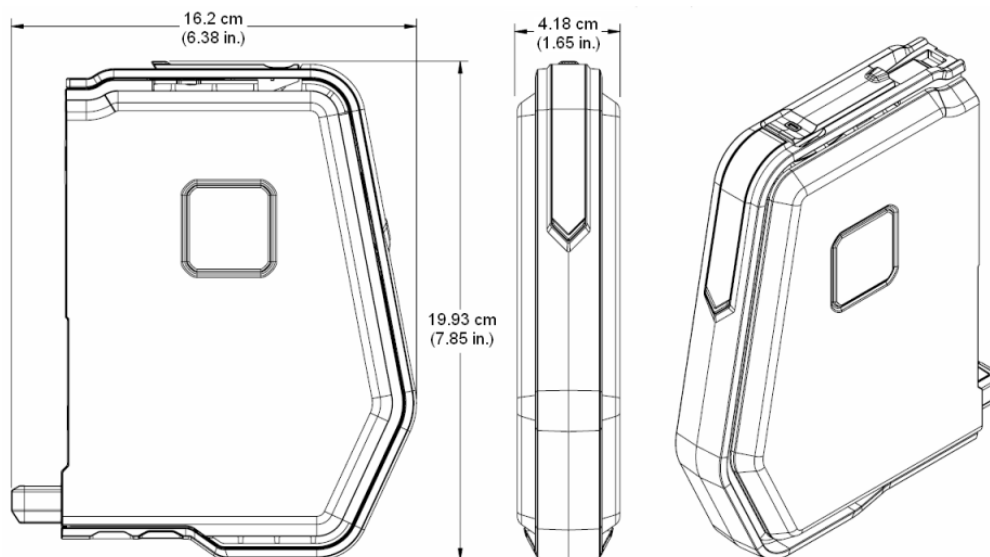

S-series controller hardware dimensions

Hardware Specifications

Specifications for the SD Plus Controller	
DST Limit	750
SCADA tags	3200
Max data values sent	2000/second
Max data values received	250/second
Max unsolicited client nodes	64
Module Execution rates	100ms, 200ms, 500ms, 1s, 2s, 5s, 10s, 30s, 60s
User Memory	48 MB
Fuse protection (internal)	3.0 A, non-replaceable fuses
Power dissipation	5.0 W typical, 7.0 W maximum
Environmental specifications:	
Operating temperature	-40° to 70° C (-40° to 158° F)
Storage temperature	-40° to 85° C (-40° to 185° F)
Relative humidity	5 to 95%, non-condensing
Protection rating	IP 20, NEMA 12
Airborne contaminants	ISA-S71.04-1985 Airborne Contaminants Class G3 Conformal coating
Shock (normal operating conditions)	10 g ½-sine wave for 11 ms
Vibration (operative limit)	1 mm peak-to-peak from 5 Hz to 13.2 Hz, 0.7 g from 13.2 Hz to 150 Hz
LED Indicators:	
Green – Power	Indicates DC power is applied.
Red – Error	Indicates an error condition.
Green – Active	Indicates that the controller is operating as the primary controller.
Green – Standby	Indicates that the controller is operating as a backup controller
Yellow flashing – Pri. CN	Indicates valid primary control network communication.
Yellow, flashing – Sec. CN	Indicates valid secondary control network communication.
External connections:	
Primary Control Network	8-pin RJ-45 connector
Secondary Control Network	8-pin RJ-45 connector

Certifications

The following certifications are available on the SD Plus controller.

■ CE:

- EMC- EN 61326-1:2006
- LVD- EN 61010-1:2001

■ CSA:

- CLASS 2252 05 - PROCESS CONTROL EQUIPMENT:

CAN/CSA-C22.2 No. 0-M91 General Requirements-
Canadian Electrical Code, Part II

CAN/CSA-C22.2 No. 61010-1-04 Safety
Requirements for Electrical Equipment for
Measurement, Control, and Laboratory Use,
Part 1: General Requirements

Complies with NAMUR NE21 per DeltaV Digital
Automation System NAMUR NE21 Installation Instructions
12P2822.

The following certifications have been submitted for
Hazardous Locations and for Marine applications. Please
verify with the appropriate certifying agency for a specific
list of approved components

■ CENELEC Zone 2 ATEX/IEC EX

EN 60079-15:2005

Certifying agency: Nemko

Certificate Number: TBD

Refer to document TBD

*"DeltaV™ Scalable Process System Zone 2
Installation Instructions"*

■ FM Approval

Class 1 Division 2 Hazardous Locations

Certifying agency: FM Approvals

Certificate Number: TBD

Refer to document TBD

*"DeltaV™ Scalable Process System Class 1
Division 2 installation Instructions"*

■ Marine Certifications:

IACS E10:2006 Rev.5 Control, protection &
Safety

- ABS Certificate of Design Assessment
- Bureau Veritas Certificate
- DNV Marine Certificate
- Lloyds Register

■ GOST Hazardous Area certification Zone 2 (Russian)

Other country specific certifications may also be available.
Verify with your local Emerson sales office to confirm any
certification requirements not listed here.

Ordering Information

Description	Model Number
SD Plus Controller	SE3006

Prerequisites

- For each controller you will need a Power/Controller carrier. Please refer to the S-series I/O Carrier product data sheet for details.
- Each controller requires a dedicated system power supply. Please refer to the S-series Power Supplies product data sheet for details.

To locate a sales office near you, visit our website at:

www.EmersonProcess.com/DeltaV

Or call us at:

Asia Pacific: 65.777.8211

Europe, Middle East: 41.41.768.6111

North America, Latin America: +1 800.833.8314 or +1 512.832.3774

For large power, water, and wastewater applications

contact Power and Water Solutions at:

www.EmersonProcess-powerwater.com

Or call us at:

Asia Pacific: 65.777.8211

Europe, Middle East, Africa: 48.22.630.2443

North America, Latin America: +1 412.963.4000

© Emerson Process Management 2011. All rights reserved. For Emerson Process Management trademarks and service marks, go to: <http://www.emersonprocess.com/home/news/resources/marks.pdf>.

The contents of this publication are presented for informational purposes only, and while every effort has been made to ensure their accuracy, they are not to be construed as warranties or guarantees, express or implied, regarding the products or services described herein or their use or applicability. All sales are governed by our terms and conditions, which are available on request. We reserve the right to modify or improve the design or specification of such products at any time without notice.

