

# DeltaV™ S-Series Traditional I/O

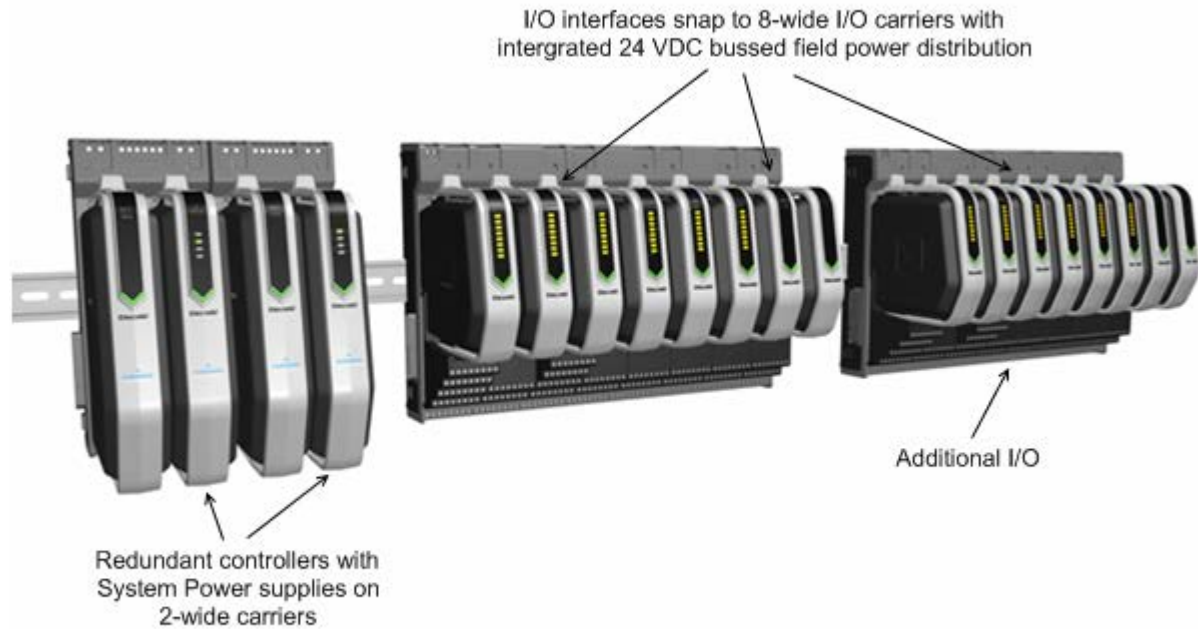

*The DeltaV™ I/O interfaces are easy to install and maintain.*

- Modular and Flexible construction
- Reduced installation time and expense
- Easy Online expansion
- Field mounted capable hardware
- 1:1 Redundancy for Traditional I/O
- Plug and Play IO

## Introduction

S-series Traditional I/O interfaces provide improved ease of installation with the same proven features of M-series I/O interfaces. This modular I/O subsystem offers flexibility during installation and is designed for extreme environmental conditions of field installations. S-series Traditional I/O is equipped with a snap in retention system for quick installation. The I/O interfaces can be installed in any of the possible 64 slots. All wiring is through the carriers and terminal blocks so that modules can easily be removed without disconnecting any wires. Modularity, fast installation, online expansion and environmentally robust hardware make DeltaV™ S-series Traditional I/O a smart choice for your process control system.



### Benefits

**Modular and Flexible construction.** The S-series Traditional I/O subsystem is designed with your investment in mind. Each controller supports up to 8 I/O carriers that form a robust, passive bus for up to 64 I/O interfaces. Each interface has a matching I/O terminal block and can be installed in any I/O slot on the bus. Carriers and interfaces can be added online, without interruption to the existing I/O communication. This modular design enables you to purchase the exact amount of I/O cards, 8-wide carriers, power/controllers, and 2-wide carriers you need and add more DeltaV I/O as your system grows.

**Reduced installation time and expense.** The DeltaV system's S-series I/O interfaces are designed for quick assembly and error proof maintenance. All carriers snap onto T-DIN rails and interfaces snap into the I/O slots without the use of any tools.

Each I/O interface has a separate wiring terminal block which connects field wiring to the interface. The I/O card can easily be removed without touching the I/O wiring on the terminal block. Some I/O cards can also use the fused terminal block, which is equipped with in-line fuses that can be pulled to isolate power to the field circuit.

Traditional I/O interfaces have I/O function keys that allow the Terminal block to be set to receive a specific I/O card. These keys ensure that the correct I/O card is always plugged into the corresponding terminal block. The keys provide a safety measure by preventing the wrong I/O card's being installed. It's incredibly easy to use and gives you time to do more.

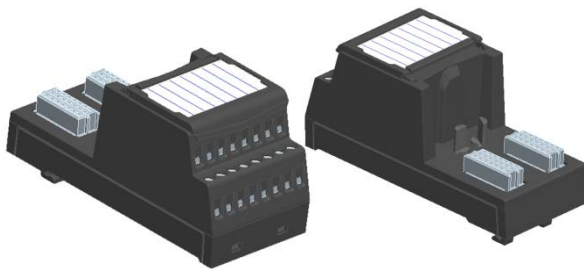

*S-series terminal blocks.*

The I/O carriers provide integrated bussed field power distribution to the I/O interfaces. The integrated bus is divided into primary and secondary power for odd and even numbered slots. Each slot is individually fused to protect power to other cards. This significantly reduces the external power distribution circuits while still providing each card with fused 24 vdc bussed field power.

**Easy Online expansion.** The S-series I/O carriers and interfaces can easily be added online, without disruption of existing I/O communication. I/O carriers can be extended online, either by directly connecting them to the right side of the existing carrier, or using extender cables to mount the new carrier on a different DIN rail. The controller automatically detects new carriers and interfaces and allows these to be auto-sensed into the configuration database.

**Field mounted capable hardware.** All S-Series Traditional I/O interfaces are rated for extreme operating temperature ranges of -40 to 70 °C (-40 to 158 °F). The interfaces can be installed in field mounted enclosures so you significantly reduce the footprint of your equipment and increase valuable control room space for other uses. This also allows you to save on wiring expenses by eliminating the need for long runs of multi-cores. The integrated design of the I/O subsystem can eliminate the need for marshaling panels. This saves you even more in your total capital costs.

### 1:1 Redundancy for Traditional I/O cards.

Increased system availability is easy with S-series Traditional I/O cards. Four Traditional I/O card types are available with redundant terminal blocks for critical field circuits. Simply install a pair of cards on the prescribed redundant terminal block and DeltaV will automatically recognize them as a redundant pair. There is no configuration other than to autosense the redundant pair. All configuration options on the channels are consistent with the simplex version of the card.

**Plug-and-play I/O.** All S-series Traditional I/O components plug into the I/O interface carrier and are auto sensed by the controller. There are no addressing switches or jumpers. Cards can be installed in any order simplifying the I/O subsystem design. New I/O interfaces are detected by the system and added to the engineering database automatically. Additional features can be enabled as needed and downloaded without disruption to existing I/O communication, allowing you to install the I/O you need today with the ability to expand tomorrow.

**Product Description**

**The S-series Traditional I/O subsystem includes:**

- I/O interface carrier ( DIN rail surface mounted) on which all I/O related components are installed.
- Bulk AC to 24 VDC power supply for field devices.
- A variety of analog and discrete I/O interfaces, consisting each of an I/O card enclosed in a common form factor and an associated I/O terminal block, which easily plug into the I/O interface carrier.
- Cable Extenders that provide flexibility in carrier mounting.



*S-series traditional I/O Interface*

The I/O cards are connected to the field with a terminal block, which allows removal of I/O cards without disconnecting any field wiring.

**I/O Cards**

A variety of analog and discrete I/O interfaces are available to meet your specific requirements. The following cards support simplex or redundant installation:

- AI 4-20 mA HART 8 channels
- AO-4-20 mA HART 8 channels
- DI NAMUR, 8-channels
- DO 24 VDC High Side, 8-channels

The following I/O cards are supported in simplex format to meet your field wiring needs.

- AI 4-20 mA HART 16 channels
- AI Isolated, 4 channels
- RTD, 8-channels
- Thermocouple, 8- channels
- Millivolt, 8-channels
- DI, High Density, 32-channels
- DI 24 VDC Isolated, 8-channels
- Pulse Count Input, 4 channels (Isolated DI)
- Sequence of Event, 16 channels (DI 24 VDC)
- DI 120 VAC Low Side Detection, 8-channels
- DI 120 VAC Isolated , 8-channels
- DO, High Density, 32-channels
- DO 24 VDC Isolated, 8-channels
- DO 120/230 VAC High Side, 8 channels
- DO 120/230 Isolated, 8 channels

All I/O cards are enclosed in a common form factor that plugs into the I/O interface carrier. The housing is clearly labeled with the enclosed I/O card type. All cards have power and internal error indicators. Eight channel cards have clearly visible channel status LEDs.

All cards meet ISA G3 corrosion specifications by the careful selection of superior electronic components and the use of conformal coating.

Pulse Counters are available on most DI cards. The supported maximum frequency varies from 0.1 Hz on AC signals to 75 or 120 Hz on 24 VDC inputs, and up to 50 KHz on the High Speed Pulse input card.

DeltaV provides control module level time stamping for log events and alarms. For greater event resolution the 16 channel Sequence of Event DI card can provide signal driven events to a resolution of +/- 0.25 ms per card, or within 1 ms per controller. Please refer to the Sequence of Events PDS for more information on Sequence of Event data collection and system options for this feature.

### I/O Card Redundancy

Redundant I/O cards are available for critical applications. The same card can be used in simplex or redundant applications. When installed on a two-wide redundant terminal block, the cards are recognized as a redundant pair by the controller. The controller scans each card and determines which card is acting as the active interface. When a fault is detected, the system automatically switches to the standby I/O card.

DeltaV Control modules reference simplex and redundant I/O channels identically and there is no special configuration required to take advantage of redundancy.

Switchover of a redundant I/O card is completed within two scans of the I/O bus. Make-before-break contacts ensure digital field instruments remain powered and the process is undisturbed. Analog output signals are briefly driven by both cards for < 5 ms during switchover of the card.

Hardware Alerts automatically report hardware integrity errors for both the primary and secondary cards. Any event that causes a switchover is also reported

automatically through the system hardware alerts and is logged in the Event Chronicle. Events that can cause a switchover include.

- Hardware failure within the active card.
- Communications failure between the active card and the controller.
- Removal of the active card from the carrier.
- Detection of a fault in the field wiring

A switchover may also be initiated from the diagnostics explorer, and the health and status of both cards and their channels are available in the diagnostics explorer.

The system automatically commissions a new standby card. In safe areas, failed cards can be replaced under power. In hazardous areas, appropriate installation procedures must be followed.

Hardware Specifications

Common Environmental Specifications for all I/O Interfaces	
Operating temperature	-40 to 70 °C (-40 to 158 °F)
Storage temperature	-40 to 85 °C (-40 to 185 °F)
Relative humidity	5 to 95% , non-condensing
Protection rating	IP 20, NEMA 12
Airborne contaminants	ISA-S71.04-1985 Airborne Contaminants Class G3 Conformal coating
Shock	10 g ½-sine wave for 11 ms
Vibration	1 mm peak-to-peak from 5 to 13.2 Hz; 0.7 g from 13.2 to 150 Hz

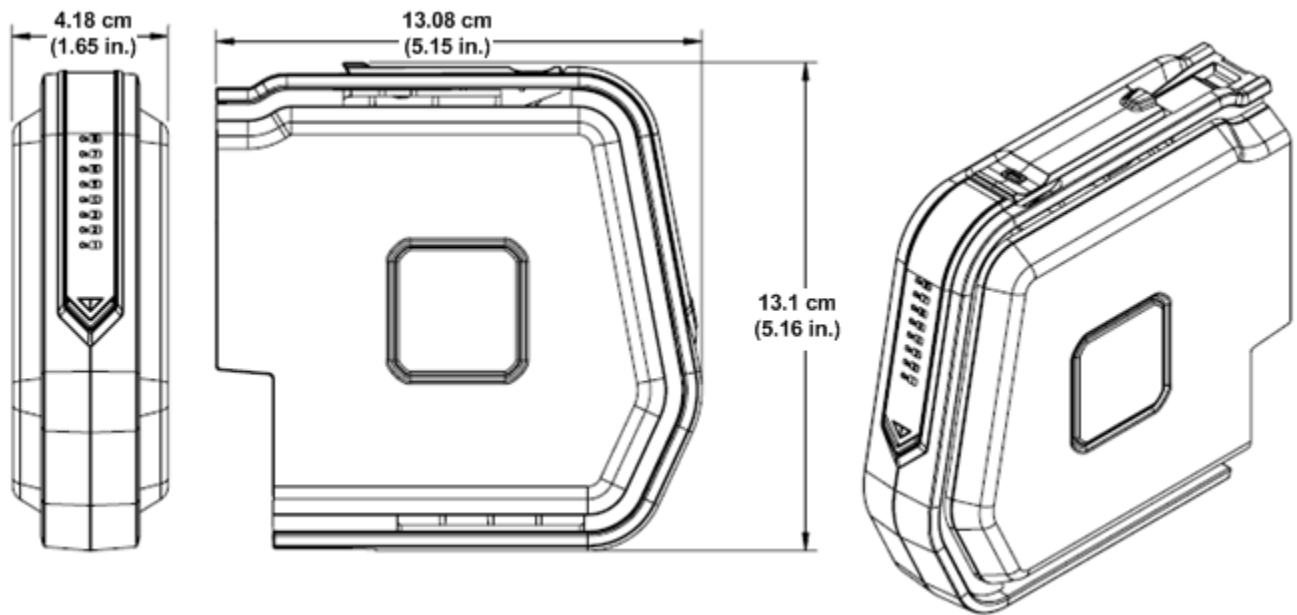

S-series Traditional I/O interface enclosure

Analog Input signals

Specifications for AI-Card, 8 channel, 4 to 20 mA, HART	
Number of channels	8
Input Sensor Types	4 to 20 mA (span), 2-wire and 4-wire
Full signal range	1 to 23 mA, with overrange checking
Transmitter Power (2-wire)	13.5 V minimum at 20 mA (current limited at 29 mA max)
Accuracy over temperature range	0.1% of span
Repeatability	0.05% of span
Resolution	16 bit A/D converter
Rolloff frequency (Anti-aliasing)	-3 dB at 2.7 Hz, -20.5 dB at 20 Hz
Calibration	None required
LocalBus current (12 VDC nominal)	175 mA typical, 250 mA maximum
Field circuit power per card	300 mA maximum at 24 VDC ( $\pm 10\%$ )
Isolation	Each channel is optically isolated from the system and factory tested to 1500 VDC.
Optional fuse	2.0 A (Terminal block option)
HART Communications support	HART pass-through for AMS Device Manager HART variable and status reporting for control functions
Hart Scan Time	600 – 800 mS (typical) per enabled channel

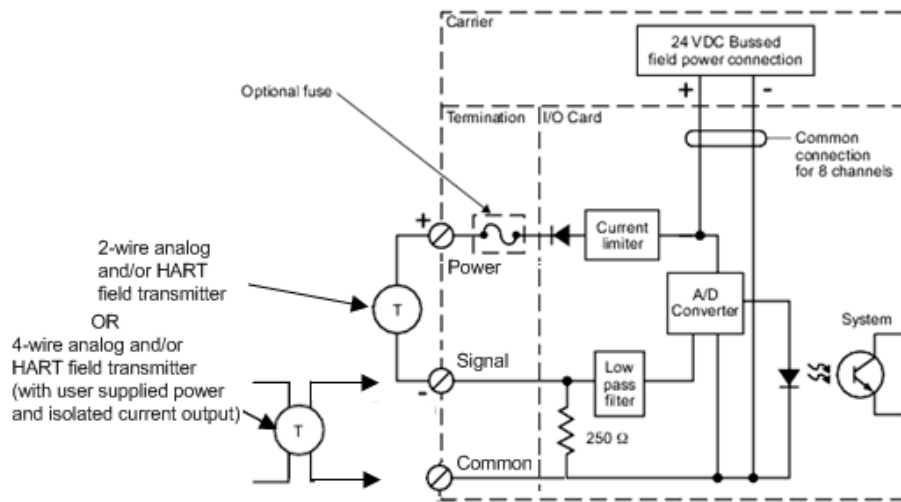

Simplified circuit and connection diagram for HART AI-card, 8 channel, 4 to 20 mA

Specifications for AI-Card 16 Channel, 4 to 20 mA, HART	
Number of channels	16
Input Sensor Types	4 to 20 mA (span), 2-wire
Full signal range	2 to 22 mA, with overrange checking
Transmitter Power	13.5 V minimum at 20 mA (max current limited at 29 mA)
Accuracy over temperature range	0.2% of span
Repeatability	0.05% of span
Resolution	16 bit A/D converter
Rolloff frequency (Anti-aliasing)	-3 dB at 2.7 Hz; -20.5 dB at 20 Hz
Calibration	None required
LocalBus current (12 VDC nominal)	85 mA typical, 150 mA maximum
Field circuit power per Card	600 mA maximum at 24 VDC
Isolation	Each channel is optically isolated from the system and factory tested to 1500 VDC.
HART Communications support	HART pass-through for AMS Device Manager HART variable and status reporting for control functions
Hart Scan Time	600 – 800 mS (typical) per enabled channel

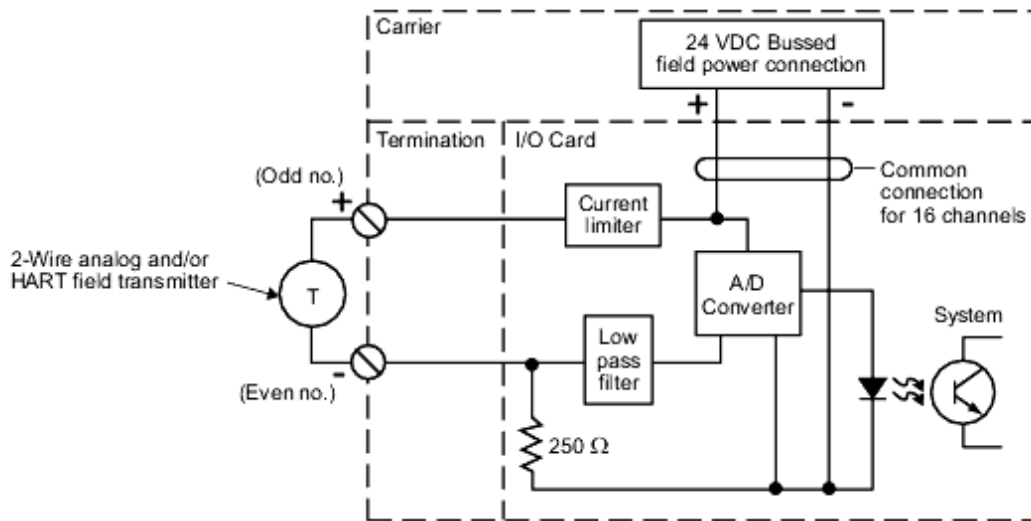

Simplified circuit diagram of HART AI card, 16 channels, 4-20 mA

Specifications for RTD Input Card, 8 channel	
RTD channels per card	8
Sensor types	Resistance, Pt100, Pt200, Pt500, Ni120, Cu10, user defined
Sensor Configuration	2 wire, 3 wire, or 4 wire
Full Scale signal range	See Table next page
Accuracy	See Table next page
Repeatability	0.05% of span
Resolution	16 bit A/D converter
Calibration	None required
Units	Degrees C, Degrees F
Sensor excitation current	100 $\mu$ A
Common mode rejection	120 dB at 50/60 Hz
LocalBus current (12 VDC nominal)	160 mA
Open sensor detection	Yes

RTD, ohms Sensor Type Specifications					
Sensor Type	Full Scale	Operating Range	25° Reference Accuracy	Temperature Drift	Resolution
Resistance	0 to 2,000 $\Omega$	0 to 2,000 $\Omega$	$\pm$ 06.2 $\Omega$	$\pm$ 0.112 $\Omega$ /°C	$\sim$ 0.02 $\Omega$
Pt100	-200 to 850°C	-200 to 850°C	$\pm$ 0.5° C	$\pm$ 0.018° C/°C	$\sim$ 0.05° C
Pt200	-200 to 850°C	-200 to 850°C	$\pm$ 0.5° C	$\pm$ 0.012° C/°C	$\sim$ 0.05° C
Pt500	-200 to 850°C	-200 to 850°C	$\pm$ 3.5° C	$\pm$ 0.063° C/°C	$\sim$ 0.18° C
Ni120	-70 to 300°C	70 to 300°C	$\pm$ 0.2° C	$\pm$ 0.006° C/°C	$\sim$ 0.02° C
Cu10	-30 to 140°C	-30 to 140°C	$\pm$ 2.0° C	$\pm$ 0.157° C/°C	$\sim$ 0.23° C
User defined	0 to 1000 $\Omega$	0 to 1000 $\Omega$	$\pm$ 0.4 $\Omega$	$\pm$ 0.009 $\Omega$ /°C	$\sim$ 0.05 $\Omega$

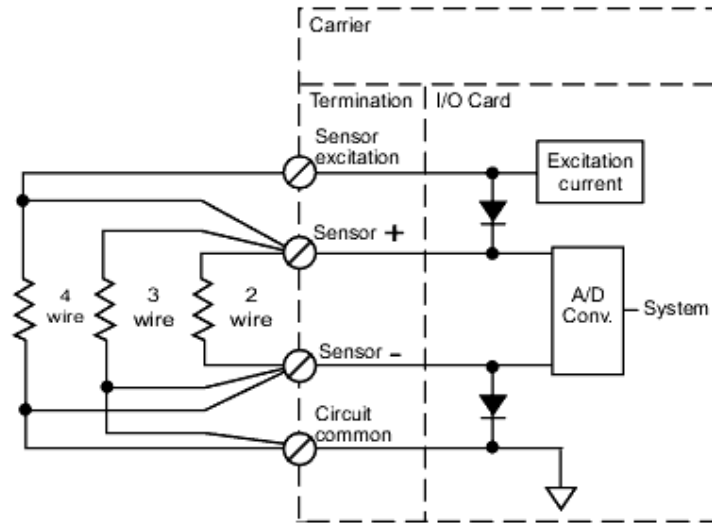

Simplified circuit diagram for RTD Input card, 8 channels

Specifications for Thermocouple/mV Input Card, 8 channel	
Channels per card	8
Sensor types	B, E, J, K, N, R, S, T, uncharacterized Low level voltage source
<input type="checkbox"/> Thermocouple <input type="checkbox"/> mV	
Sensor Ranges	See table next page
Repeatability	0.05% of span
Resolution	16 bit A/D converter
Calibration	None required
Units	Degrees C Degrees F
Cold junction compensation (Not available on mV channels)	$\pm 1^{\circ}\text{C}$
Isolation	Each channel is optically isolated from the system and factory tested to 1500 VDC. <ul style="list-style-type: none"> <li>• Channels 1, 2, 3, and 4 are isolated from channels 5, 6, 7, and 8 (verified by 1500 VDC factory test).</li> <li>• Thermocouples attached to channels 1, 2, 3, and 4 are not electrically isolated and should be within <math>\pm 0.7</math> VDC of each other.</li> <li>• Thermocouples attached to channels 5, 6, 7, and 8 are not electrically isolated and should be within <math>\pm</math></li> </ul>

Specifications for Thermocouple/mV Input Card, 8 channel	
	0.7 VDC of each other.
Common mode rejection	120 dB at DC/50/60 Hz
LocalBus current (12 VDC nominal)	210 mA
Open sensor detection	Yes

Sensor Type Specifications					
Sensor Type	Full Scale	Operating Range	25° Reference Accuracy	Temperature Drift	Resolution
B	250 to 1810° C	500 to 1810° C	± 2.4° C	± 0.056 ° C/ °C	~ 0.18° C
E	-200 to 1000° C	-200 to 1000° C	± 0.6° C	± 0.008° C/ °C	~ 0.07° C
J	-210 to 1200° C	-190 to 1200° C	± 0.8° C	± 0.011° C/ °C	~ 0.05° C
K	-270 to 1372° C	-200 to 1372° C	± 0.5° C	± 0.016° C/ °C	~ 0.18° C
N	-270 to 1300° C	-190 to 1300° C	± 1.0° C	± 0.007° C/ °C	~ 0.10° C
R	-50 to 1768° C	-50 to 1768° C	± 2.1° C	± 0.013° C/ °C	~ 0.14° C
S	-50 to 1768° C	-40 to 1768° C	± 2.2° C	± 0.067° C/ °C	~ 0.24° C
T	-270 to 400° C	-200 to 400° C	± 0.7° C	± 0.001° C/ °C	~ 0.04° C
mV Source/ Uncharacterized (no linearization or cold junction compensation.)	-100 to 100 mV	-100 to 100 mV	0.1 mV	± 0.002 mV/ °C	~ 0.003mV

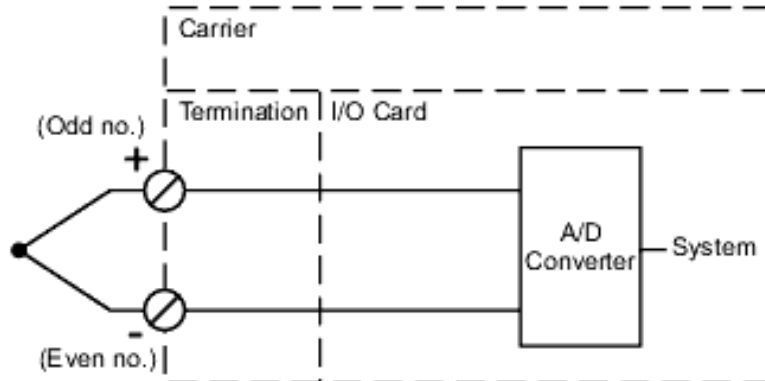

Simplified circuit diagram of Thermocouple/mV card, 8 channels



Specifications for Isolated Input Card, 4 channel	
Number of channels	4
Sensor Types <ul style="list-style-type: none"> <li>■ Thermocouple</li> <li>■ RTD Sensor Types</li> <li>■ mV and V ranges</li> </ul>	B, E, J, K, N, R, S, T, Uncharacterized PT100, PT200, Ni120, Cu10, Resistance, user-defined Refer to following tables.
Input type mix	Independently configurable
Resolution	16 bit A/D converter
Calibration	None required
Isolation	Channel to system - 600 VAC double insulation. Each channel is optically isolated from the system and factory tested to 5000 VDC. Channel to channel - 600 V basic insulation. Each channel is optically isolated from each other and factory tested to 3100 VDC. CAN/CSA-C22.2 No.1010.1-92
Common Mode Rejection	120 dB at DC/50/60 Hz
Input Impedance	10 MΩ
Roll off frequency (Anti-aliasing)	-3dB at 2.7 Hz
LocalBus Current (12 VDC nominal)	350 mA
Isolated Input Card, Thermocouple and mV Input Specifications	
Linearization error	+/- 0.003% full scale
Cold Junction Comp. Accuracy	+/- 1.0°C
Cold junction compensation (Not available on mV channels)	Local: Integrally mounted in terminal block External: Specified channel
Cold Junction Compensation range	-40 to 85°C
Open circuit detection (Thermocouple only)	Yes
Open sensor detection time	1 second

Isolated Input Thermocouple/mV/V Sensor Type Specifications					
Sensor Types	Full Scale	Operating Range	25°C Reference Accuracy	Temperature Drift	Nominal Resolution
B	250 to 1810° C	500 to 1810° C	±1.2° C	±0.116 ° C/ °C	0.09° C
E	-200 to 1000° C	-200 to 1000° C	±0.5° C	±0.004° C/ °C	0.05° C
J	-210 to 1200° C	-190 to 1200° C	±0.6° C	±0.005° C/ °C	0.06° C
K	-270 to 1372° C	-140 to 1372° C	±0.5° C	±.013° C/ °C	0.05° C
N	-270 to 1300° C	-190 to 1300° C	±1.0° C	±.015° C/ °C	0.05° C
R	-50 to 1768° C	0 to 1768° C	±1.7° C	±.083° C/ °C	0.06° C
S	-50 to 1768° C	0 to 1768° C	±1.8° C	±.095° C/ °C	0.08° C
T	-270 to 400° C	-200 to 400° C	±0.7° C	±.025° C/ °C	0.04° C
Uncharacterized (no linearization or CJC)	-100 to 100 mV	-100 to 100 mV	±0.05 mV	±.0003 mV/ °C	.0031 mV
20 mV source	-20 to 20 mV	-20 to 20 mV	±0.02 mV	0.001 mV/°C	0.0008 mV
50 mV sourc	-50 to 50 mV	-50 to 50 mV	±0.03 mV	0.0005 mV/°C	0.0017 mV
100 mV source	-100 to 100 mV	-100 to 100 mV	±0.05 mV	0.0003 mV/°C	0.0031 mV
0 - 5 V	0 to 5 V	0 to 5 V	0.005 V	0.0002 V/° C	0.00009 V
0 - 10 V	0 to 10 V	0 to 10 V	± 0.010 V	0.0004 V/° C	0.00016 V
1 - 5 V	1 to 5 V	1 to 5 V	0.0005 V	0.0002 V/° C	0.00009 V
1 V	1 V	1 V	0.0025 V	0.0002 V/° C	0.00015 V
5 V	5 V	5 V	0.005 V	0.0002 V/° C	0.00017 V
10 V	10 V	10 V	0.010 V	0.0004 V/° C	0.0003 V

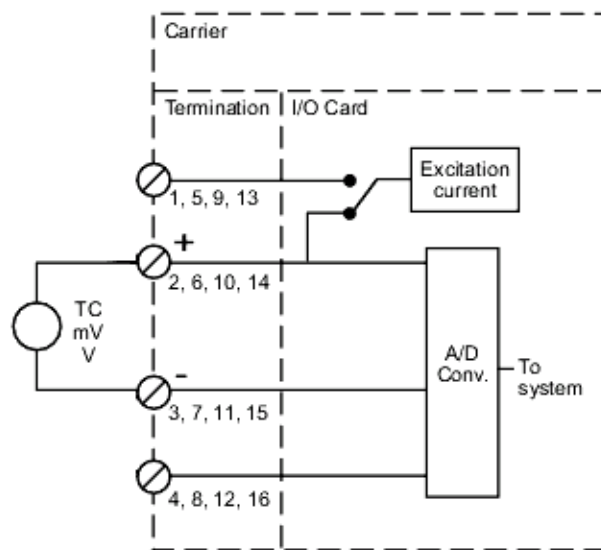

Simplified circuit diagram of Isolated Input card, Thermocouple, mV, V, 4 channels

Isolated Input Card, RTD, ohms Input Specifications	
Sensor configurations	2, 3, and 4 wire
Excitation current	100 $\mu$ A DC
Open sensor detection time	1 second
Shorted sensor detection time	1 second
Pt 100 and Pt 200 alpha	0.00385

Isolated Input Card, RTD, ohms Sensor Type Specifications				
Sensor Type	Sensor Input Range	25°C Reference Accuracy	Temperature Drift	Resolution
Pt100	-200 to 850°C	$\pm 0.5^\circ\text{C}$	$\pm 0.018^\circ\text{C}$	0.05°C
Pt200	-200 to 850°C	$\pm 0.5^\circ\text{C}$	$\pm 0.012^\circ\text{C}$	0.05°C
Ni120	-70 to 300°C	$\pm 0.2^\circ\text{C}$	$\pm 0.006^\circ\text{C}$	0.02°C
Cu10	-30 to 140°C	$\pm 2.0^\circ\text{C}$	$\pm 0.076^\circ\text{C}$	0.23°C
Resistance	1 to 1000 ohm	$\pm 0.5$ ohms	$\pm 0.018$ ohms/°C	0.02 ohms
User defined	0 to 1000 ohms	$\pm 0.4$ ohms	$\pm 0.009$ ohms/°C	$\sim 0.05$ ohms

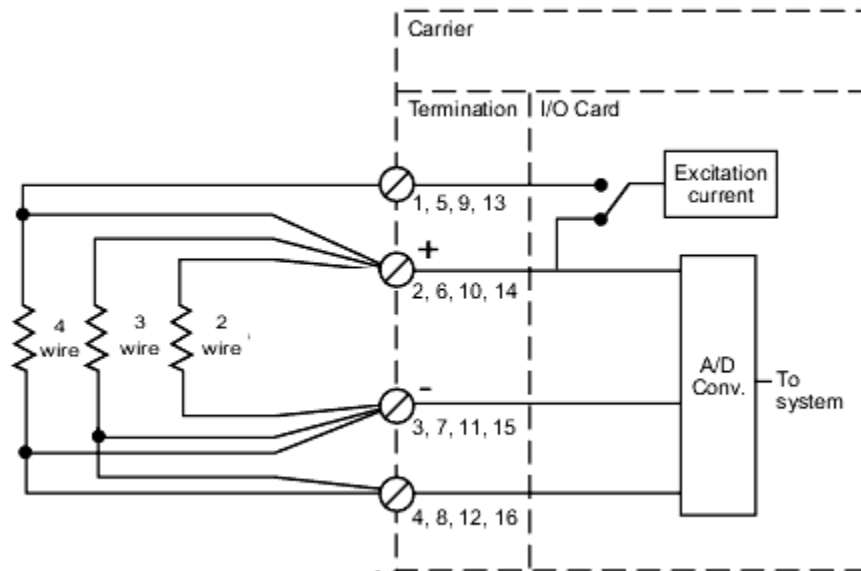

Simplified circuit diagram of Isolated Input card, RTD, 4 channels

Analog Output Signals

Specifications for HART AO Card, 8 channel, 4 to 20 mA	
Number of channels	8
Device Types	4 to 20 mA
Full signal range	1 to 23 mA
Accuracy over temperature range	0.25% of span (-40 to 60 °C) 0.4% of span (60 to 70 °C)
Resolution	14 bit D/A converter
Calibration	None Required
LocalBus current (12 VDC nominal)	175 mA typical, 250 mA maximum
Field circuit power per card	300 mA maximum @ 24 VDC (+/-10%)
Isolation	Each channel is optically isolated from the system and factory tested to 1500 VDC
Output compliance voltage	20 mA at 21.6 VDC supply into 700 Ω load
Open-Loop Detection	< 0.70 mA
Optional fuse	2.0 A (Terminal block option)
HART Communications support	HART pass-through for AMS Device Manager HART variable and status reporting for control functions
Hart Scan Time	600 – 800 mS (typical) per enabled channel

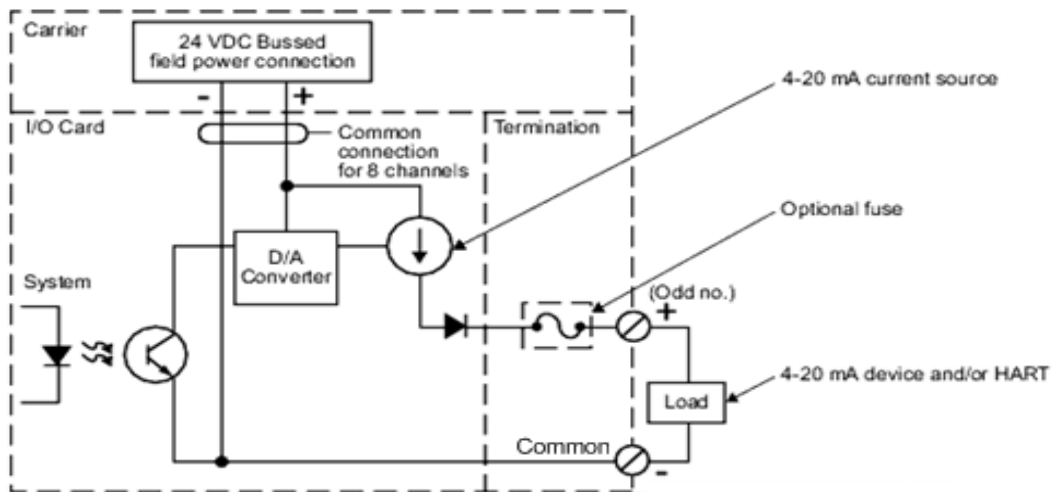

Simplified circuit and connection diagram for HART AO card, 8 channel, 4 to 20 mA

DC Voltage Discrete Input Cards

Specifications for DI Card, 8 channel, 24 VDC, NAMUR	
Number of channels	8
Input Compatibility	Compatible with NAMUR Sensors
Detection level for On	> 2.2 mA
Detection level for Off	< 1 mA
Output Impedance	5 KΩ (approximate)
Wetting Voltage	15 Volts
Fault Detection capable	NAMUR Sensors or field resistor pack
Configurable channel types:	Input
■ Discrete input	Dry contact or discrete state sensor changing <2 Hz
■ Pulse Count	Pulse train < 75 Hz
LocalBus current (12 VDC nominal)	90 mA typical, 150 mA maximum
Field circuit power per card	100 mA at 24 VDC
Isolation	Each channel is optically isolated from the system and factory tested to 1500 VDC.
Optional fuse	2.0 A (Terminal block option)

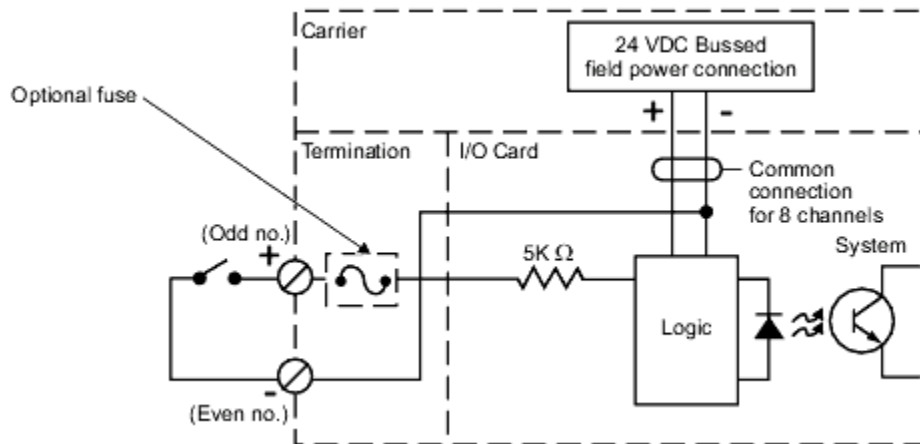

Simplified circuit and connection diagram for DI card, 8 channel, 24 VDC, NAMUR

Specifications for DI Card, 8 channel, 24 VDC, Isolated	
Number of channels	8
Detection level for On	> 10 VDC
Detection level for Off	< 5 VDC
Input impedance	5K $\Omega$ (approximately)
Wetting Current	6 mA at 24 VDC
Configurable channel types:	Input signal profile
<ul style="list-style-type: none"> <li>■ Discrete input</li> <li>■ Pulse Count</li> </ul>	Dry contact or discrete state sensor changing <2 Hz Pulse train < 120 Hz
LocalBus current (12 VDC nominal)	75 mA typical, 100 mA maximum
Field circuit power per card	None
Isolation	Each channel is optically isolated from the system and from each other and factory tested to 1500 VDC.
Optional fuse	2.0 A

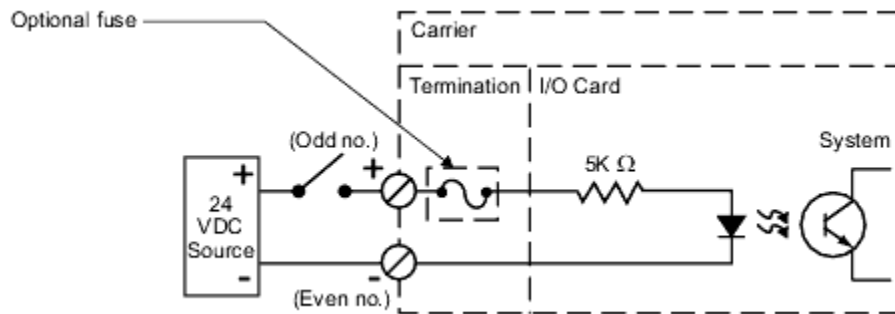

*Simplified circuit and connection diagram for DI card, 8 channel, 24 VDC, Isolated*

Specifications for DI Card, 32 channel, 24 VDC, Dry Contact	
Number of channels	32
Detection level for On	> 2 mA
Detection level for Off	< 0.25 mA
Input impedance	5K ohm (approximate)
Wetting Voltage	24 VDC
LocalBus current (12 VDC nominal)	50 mA typical, 75 mA maximum
Field circuit power per card	150 mA at 24 VDC
Isolation	Each channel is optically isolated from the system and factory tested to 1500 VDC.

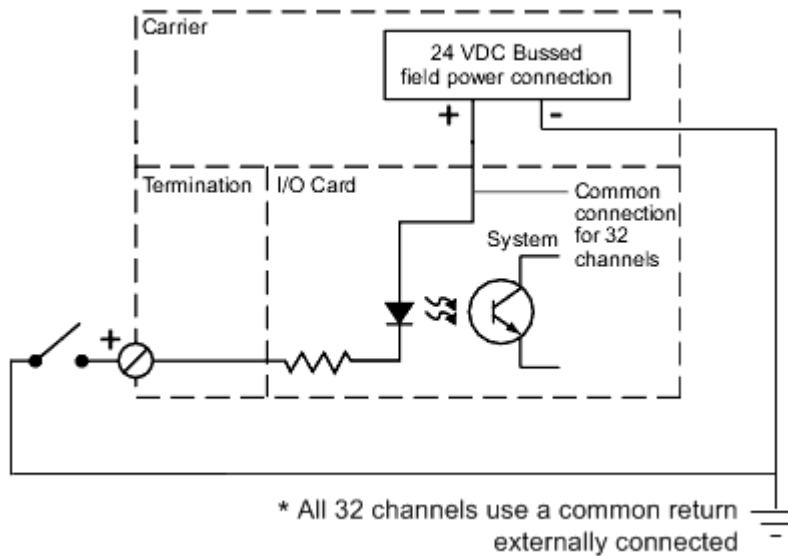

*Simplified circuit and connection diagram for High Density DI card, 32 channel, 24 VDC, Dry contact*

Specifications for PCI Card, 4 channel, 24 VDC, Dry Contact	
Number of channels	4
Detection level for ON (min.)	>4.8 VDC (>5 mA)
Detection level for OFF (max.)	<1.0 VDC (< 1 mA)
Input impedance	25 mA at 24 VDC (960 Ohms)
Input accuracy	0.1% reading (over 0.1 Hz to 50 kHz)
Resolution	+/- 1 pulse
Minimum pulse width	10 $\mu$ S
Pulse count register	32 bit unsigned integer
Input frequency	Sine wave 10 Hz to 50kHz Square wave 0.1 Hz to 50 kHz
Maximum input voltage	26.4 VDC
Wetting Voltage	24 VDC
LocalBus current (12 VDC nominal)	150 mA maximum
Isolation	Each channel is optically isolated from the system at and from other channels at 1500 VDC.

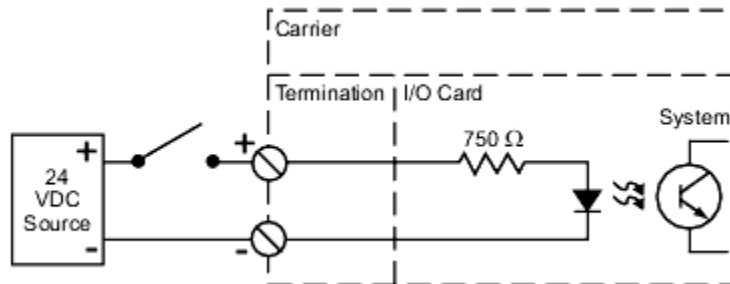

Simplified circuit and connection diagram for PCI card, 4 channel, 24 VDC, Isolated

Specifications for SOE Card, 16 channel, 24 VDC, Dry Contact	
Number of channels	16
Detection level for On	> 2 mA
Detection level for Off	< 0.25 mA
Input impedance	5K ohm (approximate)
Wetting Voltage	24 VDC
Channel Scan Rate	0.25 msec for all 16 channels
Time Stamp Accuracy (for SOE enabled channels only) <sup>1</sup>	0.25 msec from same card 1 msec from same controller
LocalBus current (12 VDC nominal)	75 mA typical, 100 mA maximum
Field circuit power per card	75 mA at 24 VDC
Isolation	Each channel is optically isolated from the system and factory tested to 1500 VDC.

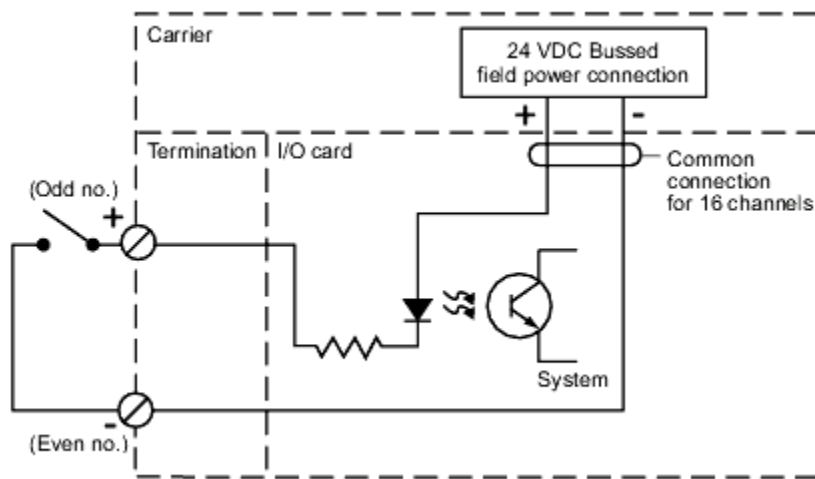

*Simplified circuit and connection diagram for SOE card, 16 channel, 24 VDC, Dry contact*

<sup>1</sup> Refer to Sequence of Event Product Data Sheet for more information on System capabilities and Sequence of Event data collection.

DC Voltage Discrete Output Cards

Specifications for DO Card, 8 channel, 24 VDC, High Side	
Number of channels	8
Output range	24 VDC +/- 10%
Output rating	1.0 A maximum continuous per channel; 3.0 A maximum per I/O Interface. (Inrush 4.0A for < 100mSec, 6.0A for < 20 mSec)
Off state leakage	1.2 mA maximum
Configurable channel types:	Output signal profile
<ul style="list-style-type: none"> <li>■ Discrete output</li> <li>■ Momentary output</li> <li>■ Continuous pulse output</li> </ul>	Output stays in last state submitted by the control logic. Output remains active for a pre-configured time period. Output is active as a percentage of a pre-configured base time period (100 ms to 100 s). Resolution = 5 ms
LocalBus current (12 VDC nominal)	75 mA typical, 100 mA maximum
Field circuit power per card	3.0 A at 24 VDC per I/O Interface (internal 10-Amp fast acting non-resettable fuse)
Isolation	Each channel is optically isolated from the system and factory tested to 1500VDC.
Optional fuse	2.0 A

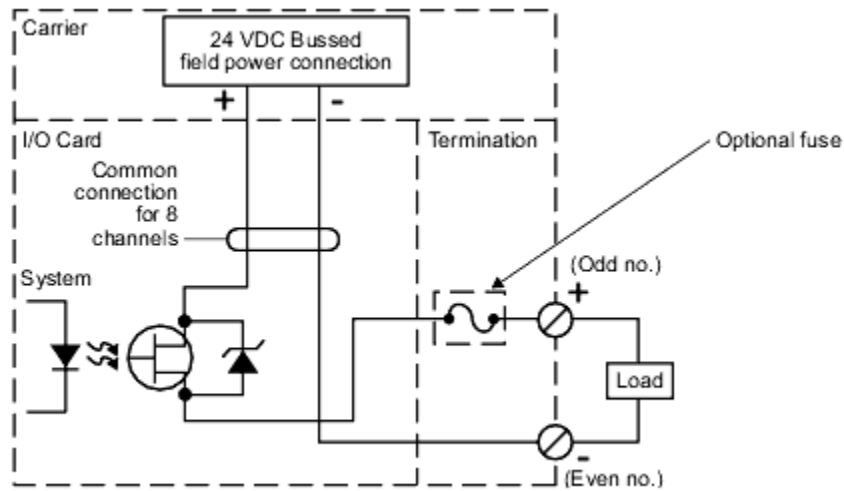

Simplified circuit and connection diagram for DO card, 8 channel, 24 VDC, High Side

Specifications for DO Card, 8 channel, 24 VDC, Isolated	
Number of channels	8
Output range	2 VDC to 60 VDC
Output rating	1.0 A (inrush 4.0 A for < 100 ms; 6A for < 20 ms)
Off state leakage	1.2 mA maximum
Configurable channel types: <ul style="list-style-type: none"> <li>■ Discrete output</li> <li>■ Momentary output</li> <li>■ Continuous pulse output</li> </ul>	Output signal profile Output stays in last state submitted by the control logic. Output remains active for a pre-configured time period. Output is active as a percentage of a pre-configured base time period (100 ms to 100 s). Resolution = 5 ms
LocalBus current (12 VDC nominal)	100 mA typical, 150 mA maximum
Field circuit power per card	None
Isolation	Each channel is optically isolated from the system and from each other and factory tested to 1500 VDC.

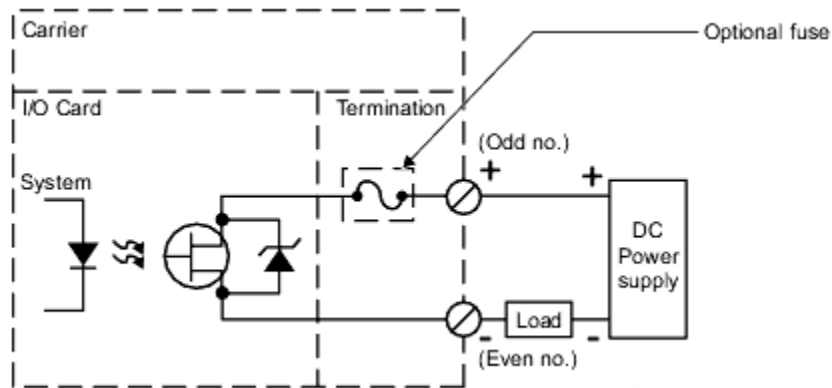

Simplified circuit and connection diagram for DO card, 8 channel, 24 VDC, Isolated

Specifications for DO Card, 32 channel, 24 VDC, High Side	
Number of channels	32
Output rating	100 mA per channel
Output range	24 VDC $\pm$ 10%
Off-state leakage	0.1 mA maximum
LocalBus current (12 VDC nominal)	100 mA typical, 150 mA maximum
Field circuit power per card	3.2 A at 24 VDC
Isolation	Each channel is optically isolated from the system and factory tested to 1500 VDC.

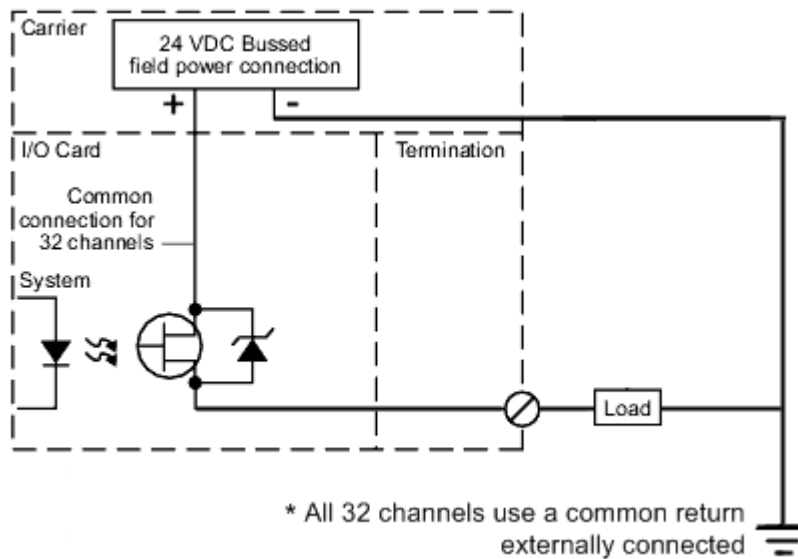

*Simplified circuit and connection diagram for High Density DO card, 32 channel, 24 VDC, High Side*

AC Voltage Discrete Input Cards

Specifications for DI Card, 8 channel, 120 VAC, Dry Contact	
Number of channels	8
Detection level for On	> 1.4 mA
Detection level for Off	< 0.56 mA
Wetting Current	2 mA at 120 VAC
Output Impedance	60 KΩ (approximately)
LocalBus current (12 VDC nominal)	75 mA typical, 100 mA maximum
Field circuit power per card	15 mA at 120 VAC
Isolation	Each channel is optically isolated from the system at 250 VAC
Optional fuse	2.0 A

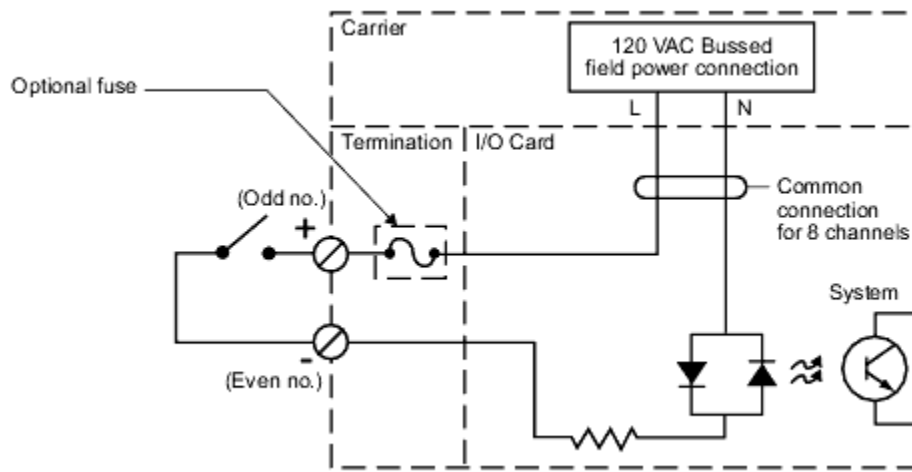

Simplified circuit and connection diagram for DI card, 8 channel, 120 VAC, Dry Contact

Specifications for DI Card, 8 channel, 120 VAC, Isolated	
Number of channels	8
Detection level for On	84 to 130 VAC
Detection level for Off	0 to 34 VAC
Wetting Current	2 mA at 120 VAC
Input Impedance	60 K $\Omega$ (approximately)
LocalBus current (12 VDC Nominal)	75 mA typical, 100 mA maximum
Field circuit power per card	None
Isolation	Each channel is optically isolated from the system at 250 VAC and from other channels at 250 VAC.
Optional fuse	2.0 A (Terminal block option)

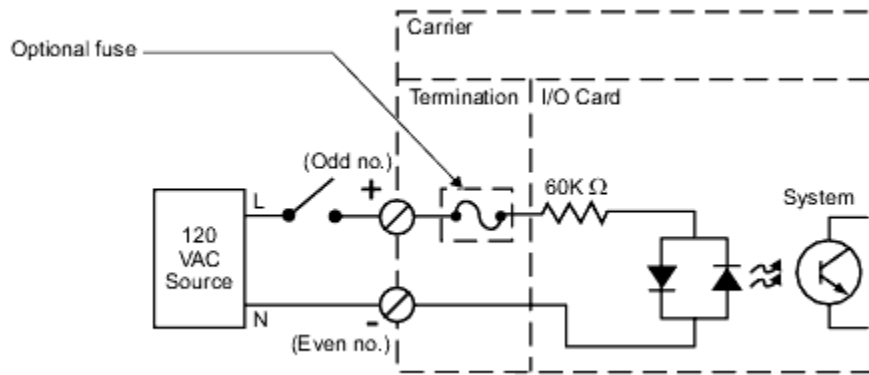

*Simplified circuit and connection diagram for DI card, 8 channel, 120 VAC, Isolated*

AC Voltage Discrete Output Cards

Specifications for DO Card, 8 channel, 120/230 VAC, High Side <sup>2</sup>	
Number of channels	8
Output range	20 to 250 VAC
Output rating	375mA average per channel 1.0 A maximum continuous per channel (inrush 5 A for < 100 ms; 20 A for < 20 ms) 3.0 A maximum per card
Off state leakage	2 mA maximum at 120 VAC 4 mA maximum at 230 VAC
Configurable channel types:	Output signal profile
<ul style="list-style-type: none"> <li>■ Discrete output</li> <li>■ Momentary output</li> <li>■ Continuous pulse output</li> </ul>	Output stays in last state submitted by the control logic. Output remains active for a pre-configured time period. Output is active as a percentage of a pre-configured base time period (100 ms to 100 s). Resolution = 5 ms
LocalBus current (12 VDC nominal)	100 mA typical, 150 mA maximum
Field circuit power per card	3.0 A at 120 VAC or 230 VAC
Isolation	Each channel is optically isolated from the system at 250 VAC
Optional fuse	2.0 A (inrush 5A for < 10 ms at 0.1% duty cycle)

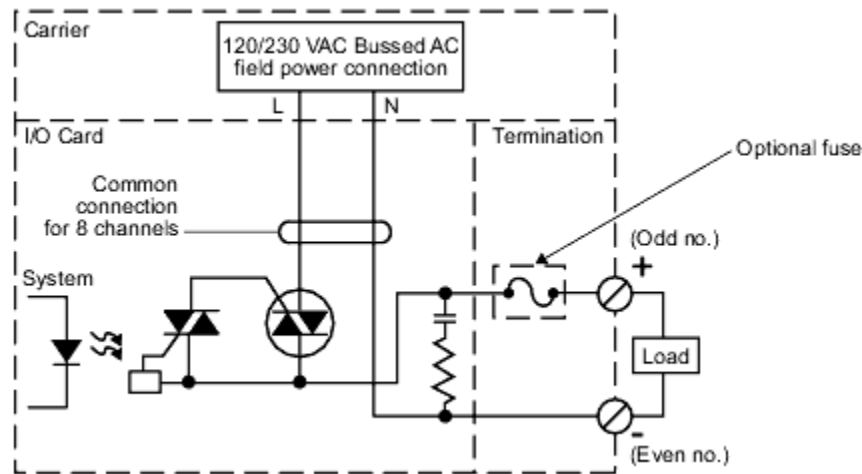

Simplified circuit and connection diagram for DO card, 8 channel, 120/230 VAC, HighSide

<sup>2</sup> High-side means the output signal is switched on the positive leg. Switching on the positive leg avoids current in field wiring when there is no output signal.

Specifications for DO Card, 8 channel, 120/230 VAC, Isolated	
Number of channels	8
Off state leakage	2 mA maximum at 120 VAC 4 mA maximum at 230 VAC
Output range	20 to 250 VAC
Output rating	375mA average per channel 1.0A maximum continuous per channel; (inrush 5A for < 100 ms: 20A for < 20 ms) 3.0A maximum per card
Configurable channel types:	Output signal profile
<ul style="list-style-type: none"> <li>■ Discrete output</li> <li>■ Momentary output</li> <li>■ Continuous pulse output</li> </ul>	Output stays in last state submitted by the control logic. Output remains active for a pre-configured time period. Output is active as a percentage of a pre-configured base time period (100 ms to 100 s). Resolution = 5 ms
LocalBus current (12 VDC nominal)	100 mA typical, 150 mA maximum
Field circuit power per card	None
Isolation	Each channel is optically isolated from system at 250 VAC and from other channels at 250 VAC
Optional fuse	2.0 A (inrush 5A for < 10 ms at 0.1% duty cycle)

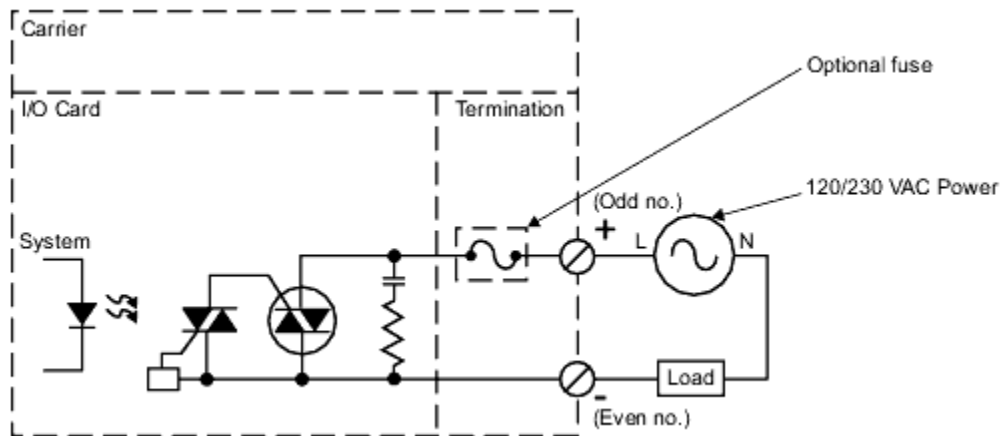

Simplified circuit and connection diagram for DO card, 8 channel, 120/230 VAC, Isolated

**I/O Terminal Blocks**

A variety of I/O terminal blocks is available to meet specific functionality and environmental requirements of the installation. The I/O interface is a combination of the I/O card and the I/O terminal block. Each I/O interface is uniquely keyed so that once installed in a carrier slot with a terminal block, that terminal block will only accept like replacement card.

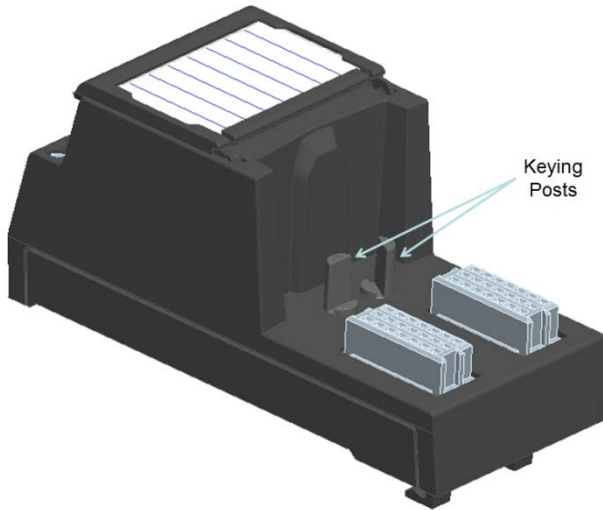

*8 channel standard Terminal block*

The keying mechanism consists of two keying posts that rotate and lock into the terminal block base. Each post has 6 positions: A-F and 1-6. Each card is assigned a unique key which is marked on the side of the I/O card:

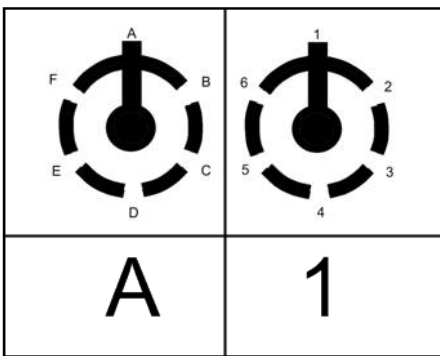

*Keying position for HART AI, 4-20 mA, 8 channel*

The keys prevent installation of an incorrect card, and the graphical information on the card makes it easy to determine if a keyed slot will accept a particular card.

There are 8 different I/O terminal blocks available to meet the wiring needs of field signals.

- 8-Channel Terminal Block
- Fused 8-Channel Terminal Block
- AI 8-Channel Terminal Block
- AI 16-channel Terminal Block
- Discrete 32-Channel Terminal Block
- Isolated Input Terminal Block
- RTD/Resistance Terminal Block
- Thermocouple Terminal Block

The following redundant I/O terminal blocks are available on some I/O interfaces, allowing a pair of cards to be installed as a redundant pair.

- Redundant AI 8-Channel Terminal Block
- Redundant AO 8-Channel Terminal Block
- Redundant Discrete 8-Channel Terminal Block

The table on the following page lists the compatible terminal blocks for each card, along with the cards unique key positions. The first terminal block listed is the recommended terminal block.

In addition to standard signal wiring, some cards may also be ordered with Mass Terminal blocks that allow these cards to be connected to a third party wiring solution, mounted in an adjacent cabinet in order to meet special signal conditioning or for optimizing field wiring solutions. Please refer to the Alliance Program website for details on approved 3<sup>rd</sup> party products.

- 16-pin Mass Terminal Block
- 24-pin Mass Terminal Block
- 40-pin Mass Terminal Block

## DeltaV Product Data Sheet

December 2011 – Page 29

## DeltaV S-Series Traditional I/O

### Traditional I/O and terminal block compatibility:

I/O Card	I/O Card Keying	Traditional I/O Terminal Blocks	Mass Terminal Blocks
AI, 8-channel, 4–20 mA, HART	A1	AI 8-Channel Terminal Block - (Supports 2 and 4 wire devices) Redundant AI 8-channel Terminal Block Fused 8-Channel Terminal Block 8-Channel Terminal Block	16-pin Mass Terminal Block - (2-wire connection) 24-pin Mass Terminal Block - (supports 2 and 4 wire devices)
AI, 16-channel, 4-20 mA HART (Simplex mode)	A2	AI 16-Channel Terminal Block	NA
AO, 8-channel, 4–20 mA, HART	A4	8-Channel Terminal Block Redundant AO 8-Channel Terminal Block Fused 8-Channel Terminal Block	16-pin Mass Terminal Block
Thermocouple, mV	C1	Thermocouple Terminal Block 8-Channel Terminal Block	NA
RTD, 8-channel	C3	RTD/Resistance Terminal Block	NA
Isolated Input Card	C2	Isolated Input Terminal Block	NA
DI, 8-channel, 24 VDC, NAMUR	B1	8-Channel Terminal Block Redundant Discrete 8-Channel Terminal Block Fused 8-Channel Terminal Block	16-pin Mass Terminal Block
DI, 8-channel, 24 VDC, Isolated	B2	8-Channel Terminal Block Fused 8-Channel Terminal Block	16-pin Mass Terminal Block
DI, 32-channel, 24 VDC dry contact	B3	Discrete 32-Channel Terminal Block	40-pin Mass Terminal Block
PCI, 4-channel	C6	Discrete 32-Channel Terminal Block	NA
SOE, 16-channel, 24 VDC	C5	Discrete 32-Channel Terminal Block	40-pin Mass Terminal Block
DO, 8-channel, 24 VDC, High Side	B6	8-Channel Terminal Block Redundant Discrete 8-Channel Terminal Block Fused 8-Channel Terminal Block	10-pin Mass Terminal Block 16-pin Mass Terminal Block
DO, 8-channel, 24 VDC, isolated	B5	8-Channel Terminal Block Fused 8-Channel Terminal Block	16-pin Mass Terminal Block
DO, 32-channel, 24 VDC high-side	B4	Discrete 32-Channel Terminal Block	40-pin Mass Terminal Block
DI, 8-channel, 120 VAC, dry contact	E1	8-Channel Terminal Block Fused 8-Channel Terminal Block	NA
DI, 8-channel, 120 VAC, isolated	E4	8-Channel Terminal Block Fused 8-Channel Terminal Block	NA
DO, 8-channel, 120 VAC/ 230 VAC, high side	F1	8-Channel Terminal Block Fused 8-Channel Terminal Block	NA
DO, 8-channel, 120 VAC/ 230 VAC, isolated	F4	8-Channel Terminal Block Fused 8-Channel Terminal Block	NA

## System Compatibility

S-series Traditional I/O hardware requires:

- SX or SD Plus controllers
- S-series horizontal carriers

S-series and M-series controllers can be installed on the same DeltaV Area Control Network in v11 and beyond. Control modules can be assigned to any controller and inter-controller references are fully supported.

DeltaV SIS Safety Logic Solvers can be installed under an S-series controller using SIS horizontal and verticalplus carriers. Refer to PDS\_SLS\_1508\_LogicSolver and PDS\_S-series\_Horizontal\_Carriers and as well to the PDS\_S-series\_VerticalPlus Carriers product data sheets for more information.

All approved 3rd party mass termination products may be used with both S-series and M-series I/O interfaces.

S-series Traditional I/O does not install on vertical carriers. For vertical I/O applications, use Electronic marshalling with CHARMS I/O.

S-series Traditional I/O horizontal carriers are not physically compatible with M-series horizontal controller carriers. Install S-series I/O interfaces with S-series controllers and M-series I/O interfaces with M-series controllers..

## Certifications

The following certifications available on all S-series Traditional I/O cards.

### ■ CE:

- EMC- EN 61326-1:2006
- LVD- EN 61010-1:2001

### ■ CSA:

- CLASS 2252 05 - PROCESS CONTROL EQUIPMENT:

CAN/CSA-C22.2 No. O-M91 General Requirements-  
Canadian Electrical Code, Part II  
CAN/CSA-C22.2 No. 61010-1-04 Safety  
Requirements for Electrical Equipment for  
Measurement, Control, and Laboratory Use,  
Part 1: General Requirements

The following certifications have been submitted for Hazardous Locations and for Marine applications. Please verify with the appropriate certifying agency for a specific list of approved components.

### ■ CENELEC Zone 2 ATEX/IEC EX

EN 60079-15:2005  
Certifying agency: Nemko  
Certificate Number: TBD

Refer to document TBD  
*"DeltaV™ Scalable Process System Zone 2  
Installation Instructions"*

### ■ FM Approval

#### Class 1 Division 2 Hazardous Locations

Certifying agency: FM Approvals  
Certificate Number: TBD

Refer to document TBD  
*"DeltaV™ Scalable Process System Class 1  
Division 2 installation Instructions"*

### ■ Marine Certifications:

IACS E10:2006 Rev.5 Control, protection &  
Safety

- - ABS Certificate of Design Assessment
- - Bureau Veritas Certificate
- - DNV Marine Certificate
- - Lloyds Register

### ■ GOST Hazardous Area certification Zone 2 (Russian)

Other country specific certifications may also be available. Verify with your local Emerson sales office to confirm any certification requirements not listed here.

## Ordering Information

Analog Input Cards and Terminal Blocks	
Description	Model Number
<b>Analog Input, 8 Channels 4-20 mA, HART</b>	
AI Card: 8 Channels 4-20 mA, HART, AI 8-Channel Terminal Block	SE4003S2B1
AI Card: 8 Channels 4-20 mA, HART, Fused 8-channel Terminal Block	SE4003S2B2
AI Card: 8 Channels 4-20 mA, HART, 16-Pin Mass I/O Terminal Block	SE4003S2B4
AI Card: 8 Channels 4-20 mA, HART, 24-Pin Mass I/O Terminal Block	SE4003S2B5
<b>Redundant Analog Input, 8 Channels 4-20 mA, HART</b>	
2 x AI Card, 8 Ch, 4-20 mA, HART, AI 8 Channel redundant Terminal Block	SE4033S2B1
<b>Analog Input 16 Channels 4-20 mA, HART</b>	
Analog Input Card: 16 Channels 4-20 mA, HART, AI 16-Channel Terminal Block	SE4003S2B6
<b>RTD/Resistance, 8 Channels</b>	
RTD Card: 8 Channels, RTD/ Resistance Terminal Block	SE4003S6B1
<b>Thermocouple/mV, 8 Channels</b>	
mV Card: 8 Channels; 8-Channel Terminal Block	SE4003S4B1
Thermocouple Card: 8 Channels; Thermocouple Terminal Block	SE4003S5B1
<b>Isolated Input, 4 Channels (Thermocouple/mV/V, RTD)</b>	
Isolated Input Card, 4 Channels; Isolated Input terminal Block	SE4003S7B1

Analog Output Cards and Terminal Blocks	
Description	Model Number
<b>Analog Output Card: 8 Channels 4-20 mA, HART</b>	
AO Card: 8 Channels 4-20 mA, HART, 8-Channel Terminal Block	SE4005S2B1
AO Card: 8 Channels 4-20 mA, HART, Fused 8-Channel Terminal Block	SE4005S2B2
AO Card: 8 Channels 4-20 mA, HART, 16-Pin Mass Terminal Block	SE4005S2B3
<b>Redundant Analog Output, 8 Channels 4-20 mA, HART</b>	
2 x AO Card, 8 Ch, 4-20 mA, HART, Redundant AO 8-Channel Terminal Block	SE4035S2B1

<b>VDC Discrete Input Cards and Terminal Blocks</b>	
<b>Description</b>	<b>Model Number</b>
<b>Discrete Input Card: 8 Channels, 24Vdc, NAMUR</b>	
DI Card: 8 Channels, 24Vdc, Dry Contact, 8-Channel Terminal Block	SE4001S2T2B1
DICard: 8 Channels, 24Vdc, Dry Contact, Fused 8-Channel Terminal Block	SE4001S2T2B2
DI Card: 8 Channels, 24Vdc, Dry Contact, 16-Pin Mass Terminal Block	SE4001S2T2B3
<b>Redundant Discrete Input, 8 Channels, 24Vdc, NAMUR</b>	
2 x DI Card, 8 Ch, NAMUR, Redundant Discrete 8-Channel Terminal Block	SE4031S2T2B1
<b>Discrete Input Card: 8 Channels, 24Vdc, Isolated</b>	
DI Card: 8 Channels, 24Vdc, Isolated, 8-Channel Terminal Block	SE4001S2T1B1
DI Card: 8 Channels, 24Vdc, Isolated, Fused 8-Channel Terminal Block	SE4001S2T1B2
DI Card: 8 Channels, 24Vdc, Isolated, 16-Pin Mass Terminal Block	SE4001S2T1B3
<b>Discrete Input Card: 32 Channels, 24 Vdc, Dry Contact</b>	
DI Card: 32 Channels, 24 Vdc, Dry Contact, Discrete 32-Channel Terminal Block	SE4001S2T2B4
DI Card: 32 Channels, 24 Vdc, Dry Contact, 40-pin Mass Terminal Block	SE4001S2T2B5
<b>Pulse Count Input Card: 4-Channels, 24 Vdc, Dry Conatact</b>	
PCI Card: 4 Channels, 24 VDC Dry Contact; Discrete 32 Channel Terminal Block	SE4015
<b>Sequence of Event Input Card: 16 Channels, 24 Vdc Dry Contact</b>	
SOE Card: 16 Channels, 24 Vdc, Dry Contact; Discrete 32-Channel Terminal Block	SE4001S5T2B4
SOE Card: 16 Channels, 24 Vdc, Dry Contact; 40-pin Mass Terminal Block	SE4001S5T2B5

VDC Discrete Output Cards and Terminal Blocks	
Description	Model Number
<b>Discrete Output Card: 8 Channels 24Vdc, High Side</b>	
DO Card: 8 Channels 24Vdc, High Side, 8-Channel Terminal Block	SE4002S1T2B1
DO Card: 8 Channels 24Vdc, High Side, Fused 8-Channel Terminal Block	SE4002S1T2B2
DO Card: 8 Channels 24Vdc, High Side, 16-Pin Mass Terminal Block	SE4002S1T2B3
<b>Redundant Discrete Output, 8 Channels, 24Vdc, High Side</b>	
2 x DO Card, 8 Ch, High Side, Redundant Discrete 8-Channel Terminal Block	SE4032S1T2B1
<b>Discrete Output Card: 8 Channels 24Vdc, Isolated</b>	
DO Card: 8 Channels 24Vdc, Isolated, 8-Channel Terminal Block	SE4002S1T1B1
DO Card: 8 Channels 24Vdc, Isolated, Fused 8-Channel Terminal Block	SE4002S1T1B2
DO Card: 8 Channels 24Vdc, Isolated, 16-Pin Mass Terminal Block	SE4002S1T1B3
<b>Discrete Output Card, 32 Channels, 24Vdc, High Side</b>	
DO Card, 32 Channels, 24Vdc, High Side, Discrete 32-Channel Terminal Block	SE4002S1T2B5
DO Card, 32 Channels, 24Vdc, High Side, 40-Pin Mass I/O Terminal Block	SE4002S1T2B6

VAC Discrete Input Cards and Terminal Blocks	
Description	Model Number
<b>Discrete Input Card: 8 Channels, 120Vac, Isolated</b>	
DI Card: 8 Channels, 120Vac, Isolated, 8-Channel Terminal Block	SE4001S3T1B1
DI Card: 8 Channels, 120Vac, Isolated, Fused 8-Channel Terminal Block	SE4001S3T1B2
<b>Discrete Input Card: 8 Channels, 120Vac, Dry Contact</b>	
DI Card: 8 Channels, 120Vac, Dry Contact, 8-Channel Terminal Block	SE4001S3T2B1
DI Card: 8 Channels, 120Vac, Dry Contact, Fused 8-Channel Terminal Block	SE4001S3T2B2

VAC Discrete Output Cards and Terminal Blocks	
Description	Model Number
<b>Discrete Output Card: 8 Channels 115/230Vac, Isolated</b>	
DO Card: 8 Channels 115/230Vac, Isolated, 8-Channel Terminal Block	SE4002S2T1B1
DO Card: 8 Channels 115/230Vac, Isolated, Fused 8-Channel Terminal Block	SE4002S2T1B2
<b>Discrete Output Card: 8 Channels 115/230Vac, High Side</b>	
DO Card: 8 Channels 115/230Vac, High Side, 8-Channel Terminal Block	SE4002S2T2B1
DO Card: 8 Channels 115/230Vac, High Side, Fused 8-Channel Terminal Block	SE4002S2T2B2

To locate a sales office near you, visit our website at:

[www.EmersonProcess.com/DeltaV](http://www.EmersonProcess.com/DeltaV)

Or call us at:

Asia Pacific: 65.777.8211

Europe, Middle East: 41.41.768.6111

North America, Latin America: +1 800.833.8314 or  
+1 512.832.3774

For large power, water, and wastewater applications

contact Power and Water Solutions at:

[www.EmersonProcess-powerwater.com](http://www.EmersonProcess-powerwater.com)

Or call us at:

Asia Pacific: 65.777.8211

Europe, Middle East, Africa: 48.22.630.2443

North America, Latin America: +1 412.963.4000

© Emerson Process Management 2011 All rights reserved. For Emerson Process Management trademarks and service marks, go to:  
<http://www.emersonprocess.com/home/news/resources/marks.pdf>.

The contents of this publication are presented for informational purposes only, and while every effort has been made to ensure their accuracy, they are not to be construed as warranties or guarantees, express or implied, regarding the products or services described herein or their use or applicability. All sales are governed by our terms and conditions, which are available on request. We reserve the right to modify or improve the design or specification of such products at any time without notice.



[www.DeltaV.com](http://www.DeltaV.com)

