

S-series Profibus DP Interface Card



The DeltaV™ S-series Profibus DP Interface Cards provide the solutions for interfacing to discrete actuators and sensors.

- Integrates Profibus DP device signals directly into control logic
- Reduces wiring costs
- Native bus interface eliminates data mapping
- Mix and match bus technologies to meet application requirements
- Redundant Profibus DP Master

Introduction

The DeltaV™ Profibus DP interface is a field-proven interface for discrete actuators and sensors. It is easy to install, reliable, and simple to use. High data throughput, simple installation, good diagnostic capabilities and error-free proven transmission technology make the DeltaV Profibus DP a good interface solution for complex devices, such as motor control centers and variable speed drive controllers.

Benefits

Integrates Profibus DP device signals directly into control logic The DeltaV system supports standard Profibus DP devices, including Motor Control Centers, Variable Speed Drive controllers as well as remote I/O products from many different manufactures. The Profibus DP master allows these devices to be integrated directly into the DeltaV S-series controller I/O subsystem where control modules able to access them. Updated device definition files can be imported into the system to implement the latest features of these products.

Reduces wiring costs. The DeltaV Profibus DP interface supports the easy integration of intelligent Motor Control Centers and Drives, which significantly decreases the wiring and associated diagrams, installation costs and test of a comparable solution based on Classic I/O.

Native DeltaV bus interface eliminates data mapping. DeltaV Profibus DP cards communicate directly to the controller, without the need for a serial interface and other intermediate converters. This greatly simplifies the configuration and maintenance. You can rely on DeltaV Profibus DP cards to provide real-time, consistently accurate inputs and outputs. As the network of field devices grows, maintenance remains constant.

Mix and match bus technologies to meet application requirements. The DeltaV system makes it easy to configure and activate the devices on a complete line of digital field busses. Profibus DP, AS-i bus, DeviceNet, FOUNDATION fieldbus, HART, and traditional I/O can be easily intermixed on an I/O card basis on the same DeltaV controller. The same configuration, diagnostic, and operator interface techniques are used to configure the system.

Redundant Profibus DP Master. DeltaV provides a redundant Profibus DP Master solution with a single port to support simplex Profibus DP segments and their devices. The redundant cards are autosensed, making DeltaV the easiest system on which to implement redundant Profibus masters. Should the active master fail, the system automatically switches to the “standby” card without user intervention. The operator is given clear notification of a switchover at the operator display.

Product Description

The DeltaV Profibus DP card uses standard RS485 cabling with two wires for data transmission. The interface is based on the master/slave principle. Sixty-four slaves may run on a pair of wires communicating with the master.

One Profibus DP segment is supported on a single interface, which can be simplex or redundant. Temperature and certification specifications are the same as other DeltaV I/O.

RS 485 transmission is the transmission technology most frequently used by Profibus DP and is often referred to as H2. It can be used in areas where high transmission speed and simple inexpensive installation are required. Twisted-pair shielded copper cable with one conductor pair is used for communications.

The Profibus DP bus structure permits step-by-step commissioning of the additional stations without influencing existing stations. Future expansions have no effect on stations already in operation.

A transmission speed between 9.6 Kbit/sec and 1.5 Mbit/sec is selected and is applicable to all devices on that segment. The DeltaV Profibus DP master can assume any address on the segment, although address 1 is typically used. The Profibus DP card can be set up with or without a segment Terminator through a jumper located in the terminal block. With the terminator disconnected, the DP card can be installed anywhere in the segment. With the terminator connected, the DeltaV Profibus DP master must be at one of the ends of the segment.¹

Each signal brought into the controller via Profibus DP counts as a DST. Profibus DP devices may also support diagnostic information, which is made available in the Diagnostics explorer and, as such, does not consume a DST. The number of DSTs per connected device can vary from 4 to several hundred. A motor starter, for example, may consume 4 to 5 DSTs, while a remote I/O island will consume as many DSTs as there are I/O connections. Performance of the Profibus DP segment will be a function of the number of devices connected and the Baud rate; typically, an additional 80—100mS latency will be introduced as compared to directly connecting the signal to a DeltaV Classic I/O channel.

DP Slave vs. DP Master

A DP slave is a peripheral device (I/O device, drive, HMI, valve, etc.) that collects input information and sends output information to the master. There are also devices that supply only input or only output information.

¹ Refer to Zone 2 installation instructions (12P2046) and/or Class 1 Division 2 installation instructions (12P1293) for details.

The amount of input and output information depends on the device type. A maximum of 244 bytes of input information and 244 bytes of output information is permitted per slave.

The DeltaV Profibus DP interface card (master) cyclically reads the input information from the slaves and cyclically writes the output information to the slaves. In addition to cyclic user data transmission, Profibus DP provides powerful functions for diagnostics and configuration.

The extensive diagnostic functions of Profibus DP enable fast location of faults. The diagnostic messages are transmitted over the bus and collected at the master. These messages are divided into the following three levels:

Station-related diagnostics. These messages concern the general operational status of the whole device (i.e., over temperature or low voltage).

Module-related diagnostics. These messages indicate that a fault is present in a specific I/O range (i.e., 8-bit output module) of a station.

Channel-related diagnostics. These messages indicate an error at an individual input/output bit (i.e., short circuit on output 7).

GSD Files

A GSD file is used to identify a Profibus DP device. (master or slave). It contains data making it possible to have manufacturer-independent configuration tools. Typical information in a GSD file is vendor information, Baud rates supported, timing information, options/features supported and available I/O signals. A GSD file must be available for every DP slave. The DeltaV system uses the information in the GSD file to set up the communications to the slave device. The GSD can be imported into the DeltaV system to add the new slave to the library.

Redundant Operation

The active and standby masters are connected to the segment at the redundant terminal block, supporting a simplex wiring scheme. Configuration of redundancy is not required as the DeltaV system automatically recognizes the redundant pair of cards and assigns device signal tags (DST) to the channels on the primary card.

Switchover time for redundant master is less than 100 ms, followed by an output signal check and rescan of the bus to ensure that the process will be undisturbed. During this time, devices maintain their outputs. The individual device communication timers should be set to prevent premature failsafe action.

The backup card monitors the health of the active master, while the controller monitors the health of the redundant pair. When a fault is detected, the system automatically switches to the backup master. A hardware alert on the integrity error for the primary card can be used to notify the operator or maintenance technician of a switchover event. The backup card is also monitored for integrity flags.

Events that can cause a switchover include.

- Hardware failure within the active card.
- Communications failure between the active card and the controller.
- Removal of the active card from the carrier.
- Detection of a fault in the field wiring

A switchover may also be manually initiated from the diagnostics explorer. The health and status of both cards and their channels are also available in the diagnostics explorer.

The system automatically commissions a new standby card. In safe areas, failed cards can be replaced under power. In hazardous areas, appropriate installation procedures must be followed.

The Standby card is fixed at address 0 and periodically declares itself on the segment as a Class 2 master to verify connectivity. Other Class 2 masters may conflict with the standby card and are not supported with the redundant Profibus card. For applications that require a class 2 master to reside on the segment, such as the Profibus/Ethernet interface for HART over Profibus, use a simplex Profibus card to avoid conflict with the standby master.

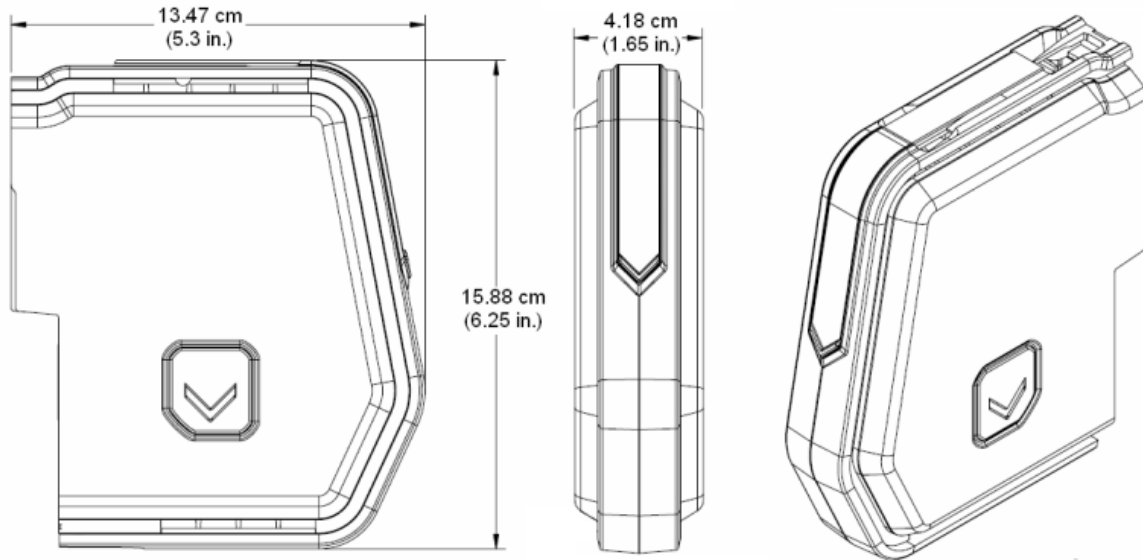

S-series Profibus DP card dimensions

Hardware Specifications

Simplex Profibus DP transmission speeds and cable lengths						
Baud rate (Kbit/sec)	9.6	19.2	93.75	187.5	500	1500
Distance/segment	1200m	1200m	1200m	1000m	400m	200m
Redundant Profibus DP transmission speeds and cable lengths						
Baud rate (Kbit/sec)	9.6	19.2	93.75	187.5	500	1500
Distance/segment	N/A	1200m	1200m	1000m	400m	200m

Profibus DP Interface Specifications	
Category	Specifications:
Number of ports	1
Number of devices	64
Storage Temperature	-40 to 85 °C (-40 to 185 °F)
Operating Temperature	-40° C to 70° C (-40° to 158° F)
Relative humidity	5 to 95% , non-condensing
Airborne contaminants	ISA-S71.04-1985 Airborne Contaminants Class G3 Conformal coating
Protection rating	IP 20
Shock	10 g ½-sine wave for 11 ms
Vibration	1 mm peak-to-peak from 5 to 13.2 Hz; 0.7 g from 13.2 to 150 Hz
Terminator	Switchable

Certifications

The following certifications are available on the S-series Profibus DP interface card.

■ CE:

- EMC- EN 61326-1:2006
- LVD- EN 61010-1:2001

■ CSA:

- CLASS 2252 05 - PROCESS CONTROL EQUIPMENT:

CAN/CSA-C22.2 No. O-M91 General Requirements-
Canadian Electrical Code, Part II
CAN/CSA-C22.2 No. 61010-1-04 Safety
Requirements for Electrical Equipment for
Measurement, Control, and Laboratory Use,
Part 1: General Requirements

Complies with NAMUR NE21 per DeltaV Digital
Automation System NAMUR NE21 Installation Instructions
12P2822.

The following certifications have been submitted for Hazardous Locations and for Marine applications. Please verify with the appropriate certifying agency for a specific list of approved components

■ CENELEC Zone 2 ATEX/IEC EX

EN 60079-15:2005
Certifying agency: Nemko
Certificate Number: TBD

Refer to document TBD
*"DeltaV™ Scalable Process System Zone 2
Installation Instructions"*

■ FM Approval

Class 1 Division 2 Hazardous Locations

Certifying agency: FM Approvals
Certificate Number: TBD

Refer to document TBD
*"DeltaV™ Scalable Process System Class 1
Division 2 installation Instructions"*

■ Marine Certifications:

IACS E10:2006 Rev.5 Control, protection &
Safety

- ABS Certificate of Design Assessment
- Bureau Veritas Certificate
- DNV Marine Certificate
- Lloyds Register

■ GOST Hazardous Area certification Zone 2 (Russian)

Other country specific certifications may also be available. Verify with your local Emerson sales office to confirm any certification requirements not listed here.

Ordering Information

Description	Model Number
S-series Profibus DP Interface Card (includes 1 Interface card and a simplex termination block)	SE4022
S-series Redundant Profibus DP I/O Interface (includes 2 Interface cards and a redundant termination block)	SE4038

To locate a sales office near you, visit our website at:

www.EmersonProcess.com/DeltaV

Or call us at:

Asia Pacific: 65.777.8211

Europe, Middle East: 41.41.768.6111

North America, Latin America: +1 800.833.8314 or
+1 512.832.3774

For large power, water, and wastewater applications

contact Power and Water Solutions at:

www.EmersonProcess-powerwater.com

Or call us at:

Asia Pacific: 65.777.8211

Europe, Middle East, Africa: 48.22.630.2443

North America, Latin America: +1 412.963.4000

© Emerson Process Management 2011. All rights reserved. For Emerson Process Management trademarks and service marks, go to:
<http://www.emersonprocess.com/home/news/resources/marks.pdf>.

The contents of this publication are presented for informational purposes only, and while every effort has been made to ensure their accuracy, they are not to be construed as warranties or guarantees, express or implied, regarding the products or services described herein or their use or applicability. All sales are governed by our terms and conditions, which are available on request. We reserve the right to modify or improve the design or specification of such products at any time without notice.