

S-series IS Electronic Marshalling

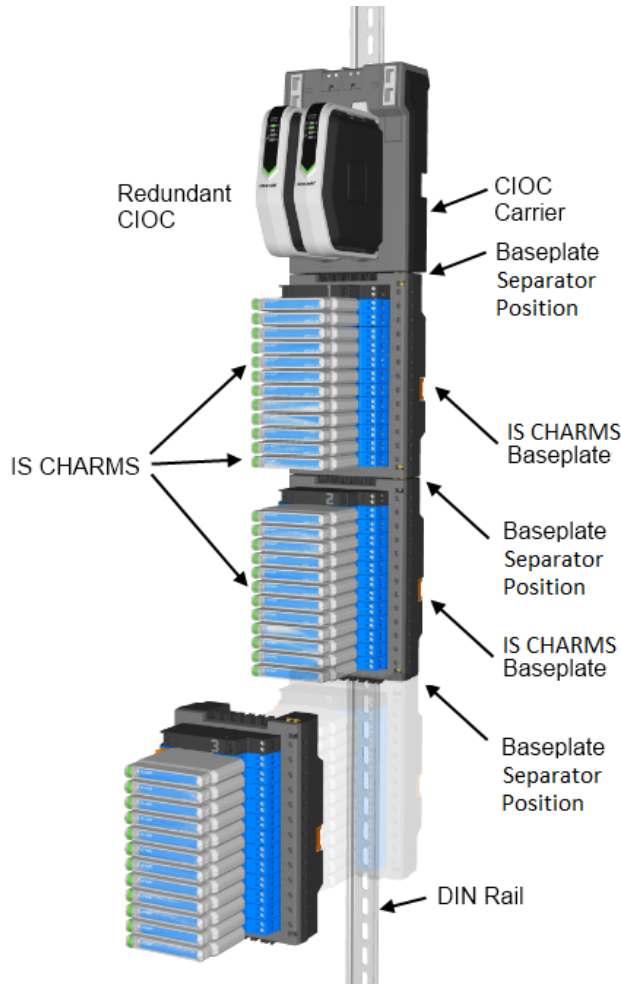

The DeltaV™ CHARM I/O Card (CIOC) with IS CHARMS

- Intrinsically Safe I/O anywhere you need it
- Integrated galvanic Isolation per channel
- Reduces installed cost of system
- Fully redundant architecture
- Field mounted capable hardware
- Plug and play I/O

Introduction

DeltaV™ S-series Electronic Marshalling delivers a new level of control system I/O performance with unprecedented flexibility and ease of use. The addition of Intrinsically Safe (IS) CHARMS provides significant savings in system design, installation cost and ease of maintenance expected with Electronic Marshalling, with the added safety for field wiring to hazardous areas. The reduced footprint and associated elimination of separate barriers and the associated inter cabinet wiring makes for a more robust installation with significant cost savings.



Benefits

Intrinsically Safe I/O anywhere you need it. DeltaV CHARM I/O Card (CIOC) supports both conventional and IS CHARMs, providing an unprecedented flexibility in control system I/O topology. Using standard Ethernet infrastructure hardware you can add I/O anywhere you need it. From a local I/O cabinet to remote enclosures miles away, simply install the hardware and connect it to the DeltaV control network. Each I/O card can serve I/O signals to any of four controllers in the system with 50 ms updates for fast, reliable control.

Integrated galvanic isolation per channel. Each I/O channel has a dedicated CHARM that provides both signal characterization and galvanic isolation for intrinsically safe applications. IS barriers are integrated inside the CHARM to provide single channel fault isolation as well as electrical isolation and energy limiting circuitry that meets IEC Ex ia ratings.

Reduces installed cost of system. DeltaV Electronic Marshalling helps reduce overall system cost by eliminating internal cabinet cross wiring, reducing overall footprint, simplifying I/O channel assignments, and reducing FAT activities. Electronic Marshalling provides separation between I&E hardware installation schedules and control strategy development. Wiring can begin earlier knowing any late changes can be done without lifting a wire. Separation of the controller and I/O allows more efficient cabinet designs and accommodates late scope changes by adding I/O anywhere. Adding additional control capacity does not require re-wiring I/O. Simply assign the control modules and their I/O signals to the new controller, without lifting a wire.

Fully redundant communications. The CIOC architecture is fully redundant. This starts with the two I/O cards on the carrier. The carrier has redundant communication modules for primary and secondary network connections. There are two 24 VDC input power connections. The carrier connects to the IS CHARMs baseplates and provides redundant power and communication buses to the CHARMs. Everything is redundant down to the individual channel.

Field mounted capable hardware. All components of the CIOC are rated for installation in Class 1/Div 2 or Zone 2 hazardous locations. The extended operating temperature ranges and G3 environment rating allows them to be installed in field mounted junction boxes. This further reduces the footprint required in central equipment rooms, as well as reduces the overall wiring infrastructure of traditional multi-core instrumentation cable.

Plug and Play I/O. The DeltaV CIOC has been designed for ease of use, both in physical installation and its software tools. Components snap together with secure DIN-rail latches and interlocking carrier connectors.

Attach a series of 96 I/O channels to a DIN-rail in a matter of minutes. Insert the CHARMs and auto sense the node to create the I/O definition automatically in your DeltaV configuration database. CHARMs use a self keying system to automatically set a channel for a specific CHARM type. Users cannot mistakenly insert a CHARM into the wrong terminal block. Assign all, one or any number of channels to a controller with a simple click or drag and drop.



IS CHARM and Terminal Block

Field power is provided through a redundant 24VDC bus to each CHARM. Each IS CHARM provides galvanically isolated field power through an internal isolation transformer, eliminating external wiring to barriers.

Product Description

IS Electronic Marshalling hardware includes:

- CHARM I/O Carrier (DIN rail mounted and supports redundant pair of CHARM I/O Cards, redundant 24 VDC power connectivity, and redundant Ethernet communication modules)
- CHARM I/O Card (provides communication between CHARMs and the Ethernet I/O network to S-series controllers)
- IS CHARM Baseplate (DIN rail mounted with interleaving power and bus connectors. Supports 12 IS CHARMs and their terminal blocks)
- IS CHARM Terminal Block (removable terminal block providing terminal connections to field wiring and physical latch for CHARM)
- IS CHARMs (Characterization Module for each field signal. Provides galvanic isolation, fault isolation and basic analog to digital conversion to the redundant communication bus)
- Labeling features for baseplate and channel identification.
- Cable Extenders that provide flexibility in carrier mounting.
- I/O bus termination (provides bus terminations for redundant I/O bus)

Intrinsically Safe CHARMs are designed to meet IEC EX ia level of safety and are suitable for connecting to field devices installed in Class 1 Division 1 Hazardous Locations or Zone 1/0 Hazardous Areas. The CHARM I/O Card and IS CHARMs are rated for installation in a Class 1 Division 2 Hazardous location, a Zone 2 hazardous area or in the safe area.

The CHARM I/O card carrier is mounted to the top of a vertical DIN rail and up to eight CHARM Baseplates are mounted below it. IS CHARM Baseplates and regular CHARM Baseplates can be combined on the same CIOC, provided installation rules are respected. The baseplates snap easily to the DIN rail as they are connected to each other. The bus termination assembly is attached at the bottom. A standard DIN-rail lock is used to keep the entire assembly in place.

Each IS baseplate is ordered pre-loaded with 12 IS terminal blocks that are ready to receive field wires from 2, 3 and 4-wire devices. Electronic Marshalling eliminates the need to scramble the field wiring or to partition the I/O in order to match signals to channel types of specific cards. Simply connect field signal multi-cores in an orderly fashion as desired. Insert the appropriate IS CHARM into each terminal block to complete the field circuit and the signal is ready to be used by any one of 4 S-series controllers. No cross-wiring required..

All IS CHARMs are energy limited devices that prevent the possibility of an explosion, even if wires are accidentally shorted together. In addition, each IS CHARM acts as a circuit protection device and field wiring disconnect. Each IS CHARM provides surge protection to meet industry standards in the area of EMC. Under extreme overvoltage conditions due to incorrect field wiring, the IS CHARM will act as a fuse to protect adjacent channels. Signal faults are thus isolated to the single IS CHARM.



CHARM I/O Card (CIOC) with IS CHARMS and Baseplate Separator in Place



IS CHARMS can be partially ejected to a locked position that disconnects the field wiring from the system to perform field maintenance actions or to remove power to a field device. Activating the IS CHARM latch ejects the IS CHARM to the detent position. Closing the latch locks the IS CHARM in place and isolates the field wiring for field work.

IS CHARM Latch Mechanism

The CIOC communicates over a redundant Ethernet network with up to 4 controllers, allowing great flexibility and ease of system expansion. Additional controllers can be added to accommodate increased control scope and I/O can be reassigned without changing the physical wiring.

IS CHARMS can be added to any existing IS baseplate position and autosensed online. Additional CIOC's can be added online.

IS CHARM Types

A variety of analog and discrete IS CHARMS are available to meet your specific requirements. The following IS CHARMS are available in v11.3.1:

- AI 4-20 mA HART
- AO 4-20 mA HART
- DI NAMUR
- DO 45 mA

All IS CHARMS have a bi-color Power/Integrity LED that indicates the health of the IS CHARM. The indications provide clear, actionable instruction to the maintenance personnel.

- Green Solid: Normal Operation
- Green Blink: Normal awaiting configuration
- Red Blink: Fault detected on wiring
- Red Solid: Internal Fault detected

Discrete IS CHARMS have a Yellow LED to indicate the state of the field signal.

All IS CHARMS meet ISA 71.04-1985 severity level G3 (harsh) corrosion specifications.

The IS DI NAMUR CHARM supports a pulse counter with a maximum frequency of 10 KHz.

I/O Terminal Block Options

IS CHARMS are designed to work with the IS Terminal Block, which is light blue in color, designating the field wiring as intrinsically safe. IS CHARMS are mechanically different and will not install in non-IS terminal blocks, ensuring there is no error in the installation.

The IS Terminal Block has 4 terminals, supporting traditional discrete and as well analog 2 & 4 wire sensor/actor field instrumentation signals

IS CHARM Keying Posts

The IS Terminal Blocks contain keying posts that are *automatically* set and locked to the unique position of the

installed IS CHARM. The keys prevent the insertion of an incorrect CHARM during maintenance activities. The IS Terminal Blocks are shipped with the keys in a neutral position and are set when an IS CHARM is inserted. If needed, the keys can be manually reset to allow a channel to be re-tasked for a different signal type.

The keying mechanism consists of two keying posts that rotate and lock into the IS terminal block base. Each IS CHARM type is assigned a unique key setting

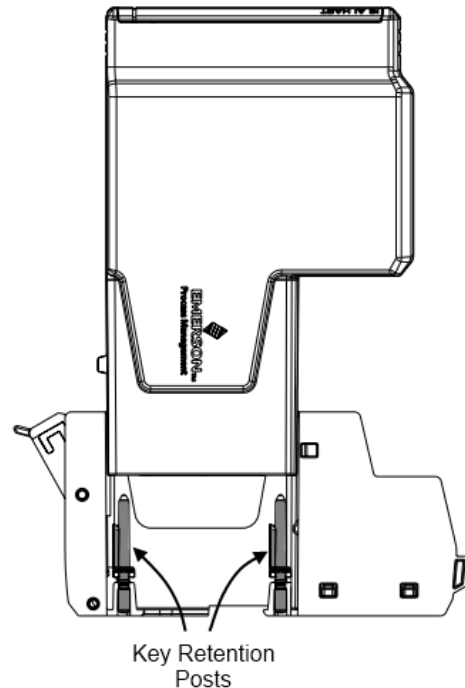

IS CHARM Terminal block

IS CHARM Baseplates

IS CHARM baseplates are mechanically different than non-IS baseplates, ensuring there is no error in the installation of the Terminal Blocks or CHARMS (non-IS). A [baseplate separator](#) is needed on the beginning and on the end of any IS CHARM baseplate row, also in between any of the IS CHARM baseplates. You can add IS CHARM baseplates to non-IS CHARM baseplates and any of the other components, like the CIOC carrier, CHARM baseplate extenders and CHARM baseplate Terminators.

Hardware Specifications

Common Environmental Specifications (all components)	
Operating temperature	-40 to 70 °C (-40 to 158 °F)*
Storage temperature	-40 to 85 °C (-40 to 185 °F)
Relative humidity	5 to 95% , non-condensing
Protection rating	IP 20, NEMA 12
Airborne contaminants	ISA-S71.04-1985 Airborne Contaminants Class G3 Conformal coating
Shock	10 g ½-sine wave for 11 ms
Vibration	1 mm peak-to-peak from 5 to 13.2 Hz; 0.7 g from 13.2 to 150 Hz

* When used with copper Ethernet I/O Ports (Copper IOP). When used with the Fiber Optic I/O Ports (Fiber Optic IOP), the operating temperature range is limited to -40 to 60 °C (-40 to 140 °F).

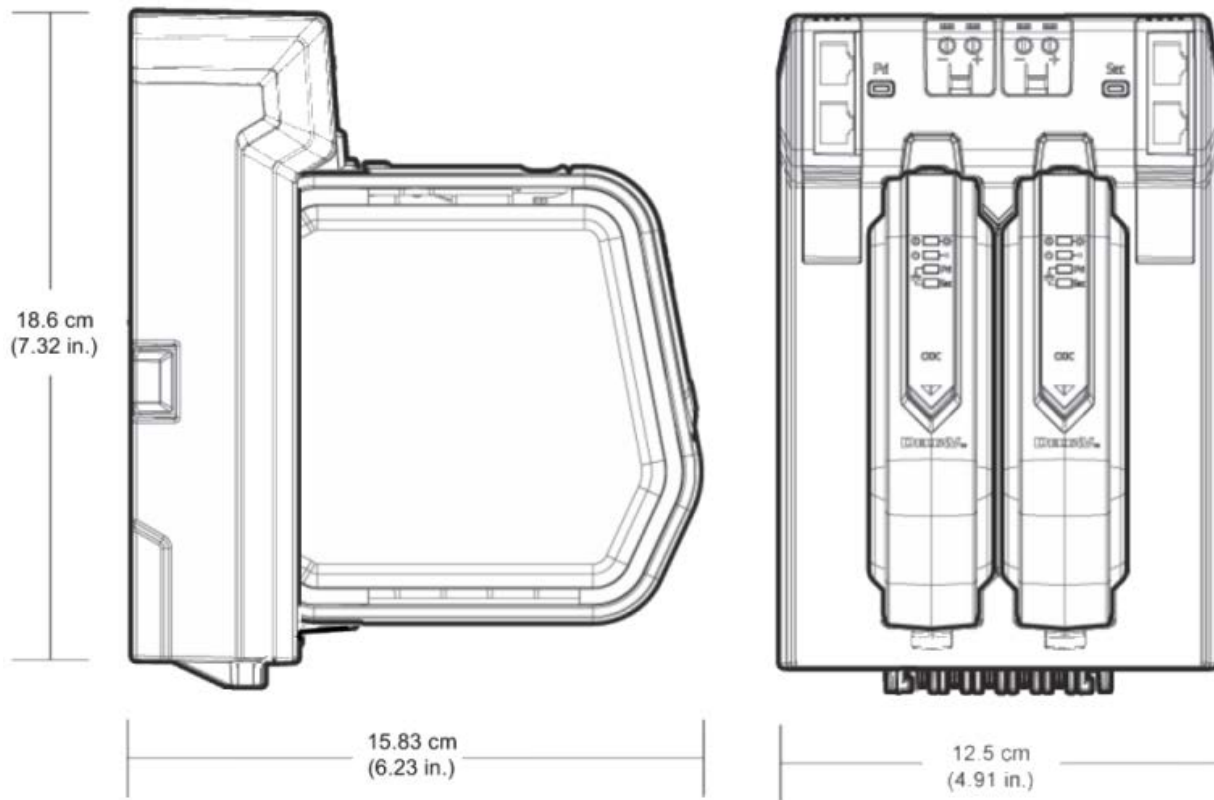

CHARM I/O Card and Carrier

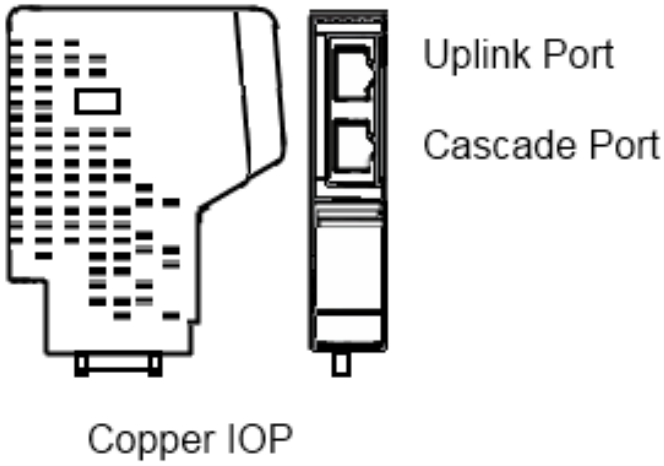

Operating Temperature -40 to 70 °C (-40 to 158 °F)

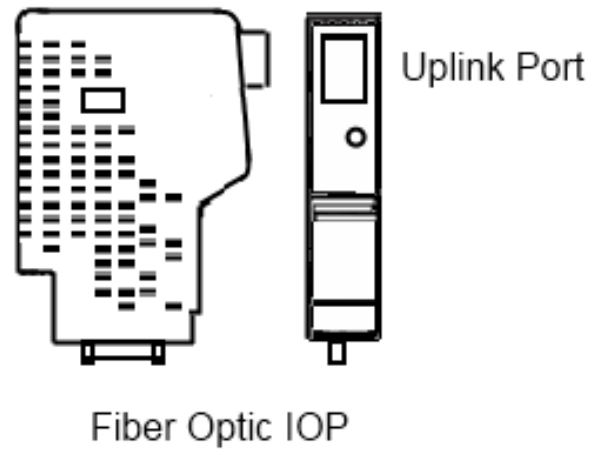

Operating Temperature -40 to 60 °C (-40 to 140 °F)

CIOC Carrier Ethernet Communication Modules

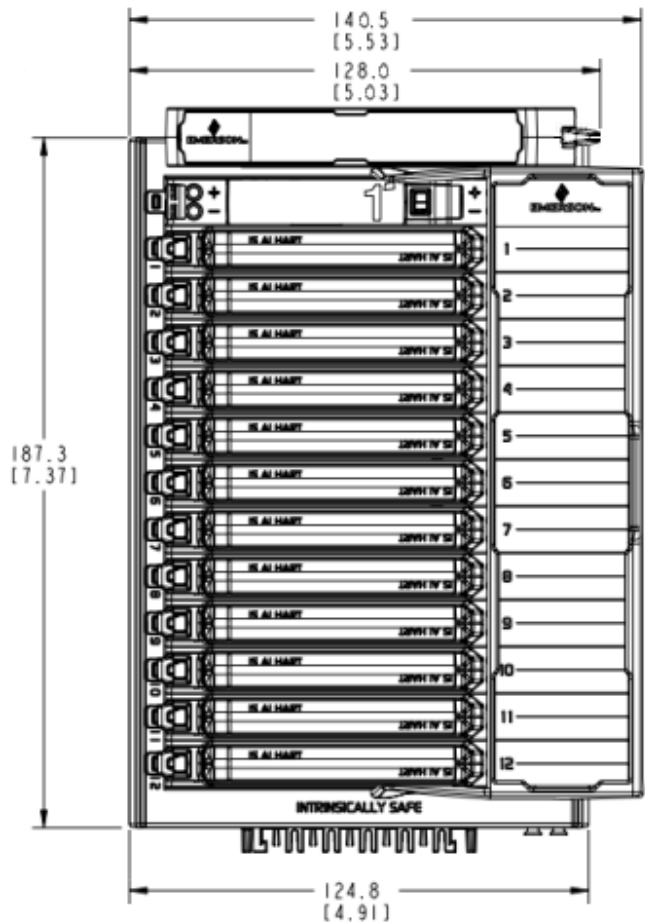
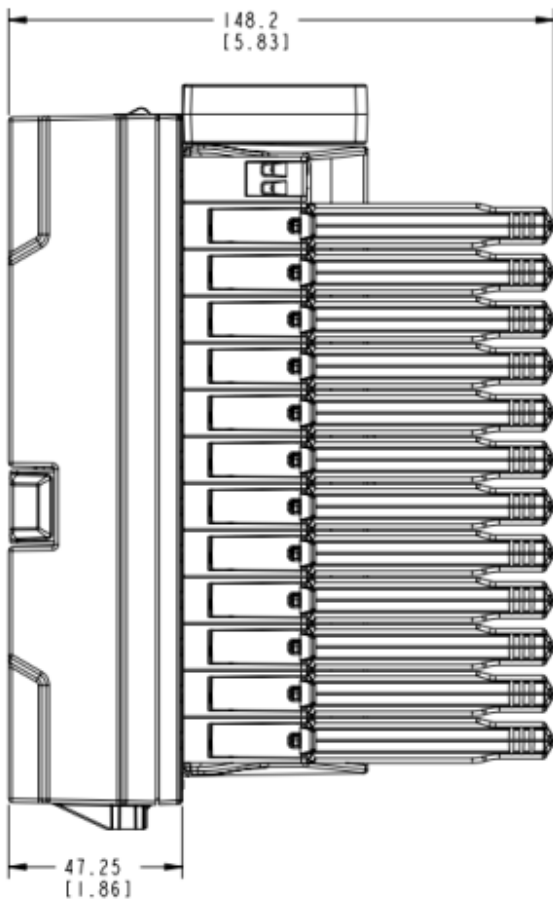

IS CHARM Baseplate with Separator, IS CHARMS and Label Plates in Place

S-series IS Electronic Marshalling

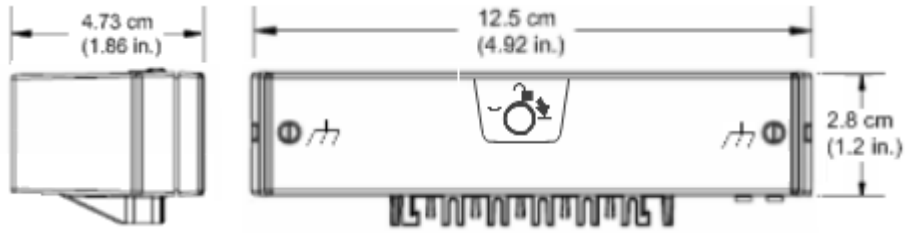

CHARM Baseplate Terminator, Top

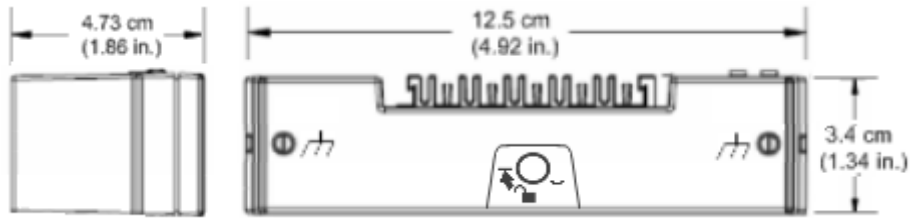

CHARM Baseplate Terminator, Bottom

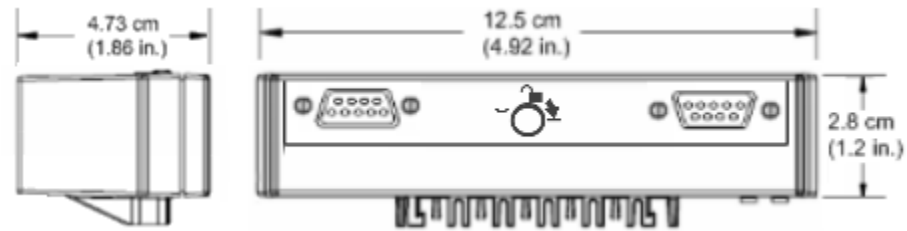

CHARM Baseplate Extender, Top

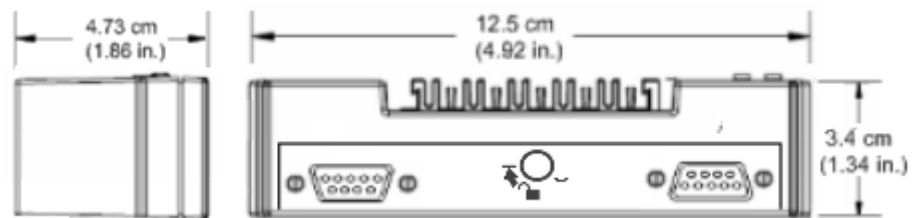

CHARM Baseplate Extender, Bottom

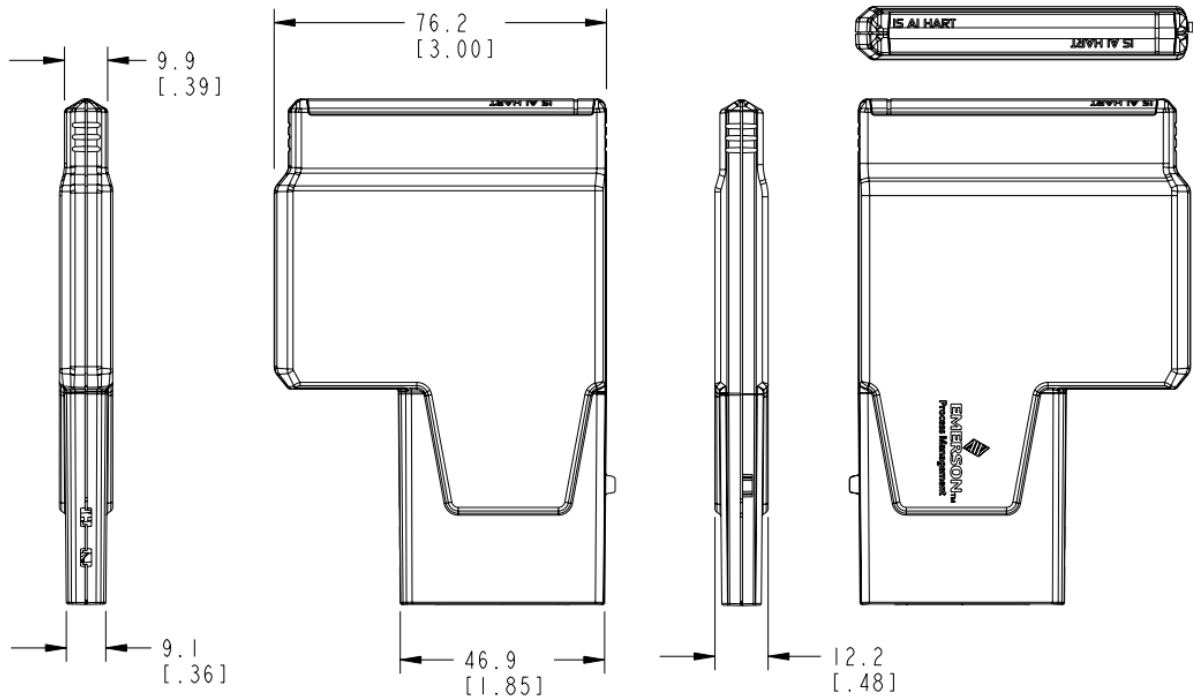

IS CHARM

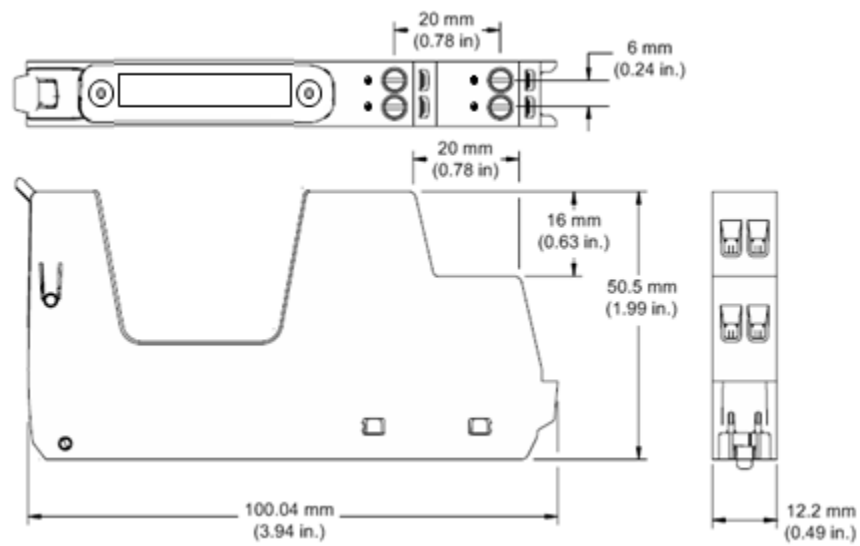

IS CHARM Standard Terminal Block

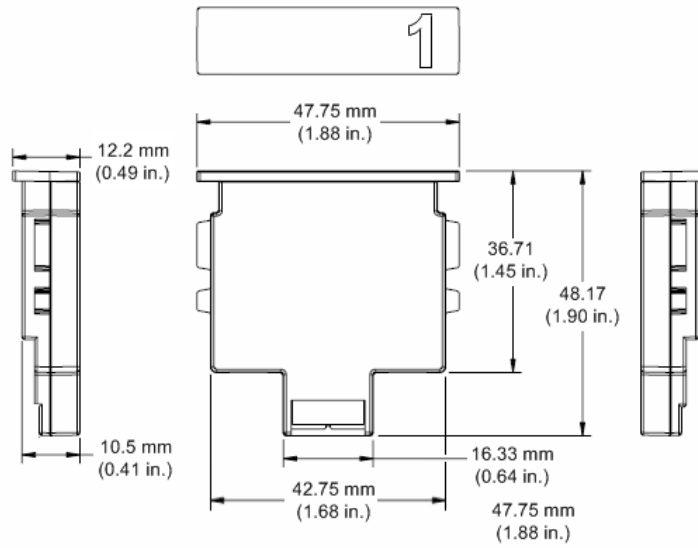

Address Plug

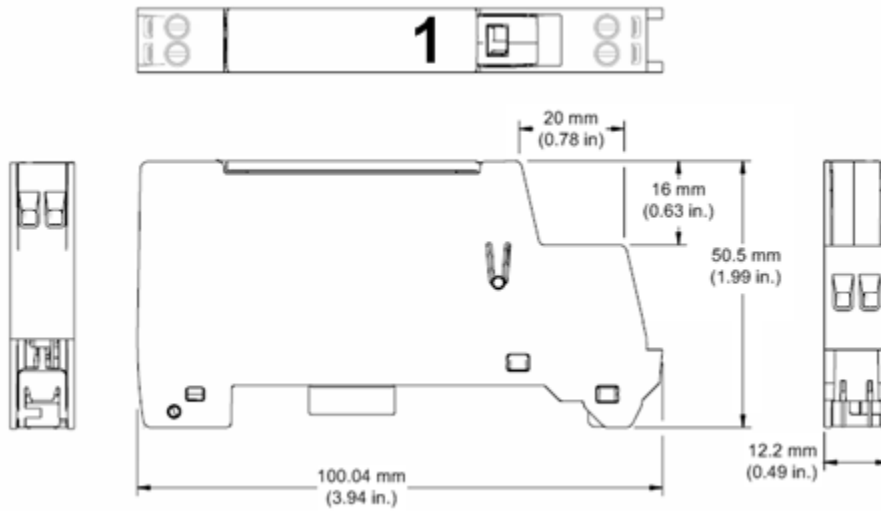

Address Plug Terminal Block for IS Baseplate

CHARM I/O Card hardware

Specifications for CHARM I/O Card Carrier	
Number of I/O Cards per carrier	2 (redundant pair)
Input power (redundant)	24 VDC \pm 20% at 12 A maximum
Redundant Ethernet connections	Fiber-optic: 100BASE-FX with MTRJ connectors; <ul style="list-style-type: none"> - Full duplex operation; - Multi-mode - 2 km nominal distance. <ul style="list-style-type: none"> • Copper twisted pair: 10/100BASE-TX with RJ45 connectors; <ul style="list-style-type: none"> - Half/Full duplex operation - 100 m distance
Mounting	DIN rail Latch to T-type rail
Specifications for CHARM I/O Card	
Number of I/O Channels	96 Channels, Individually defined signal types
Number of I/O Clients	4 (Controllers)
Number of CIOC's per Controller	16
Number of CIOC's per system	300
I/O update rates	50ms, 100ms, 250ms, 500ms
User memory	N/A
CIOC power (24 VDC)	0.28 Amps per Redundant CIOC node (includes two cards and two communication modules) (individual CHARM power requirements are in addition)
CIOC Heat Dissipation	6.68 Watts per Redundant CIOC node <ul style="list-style-type: none"> - 2.0 Watts per CIOC - 1.34 Watts per Copper Ethernet I/O Communication Port - 2.0 Watts per Fiber Optic I/O Communication Port
CIOC output to CHARMs	6.3 VDC redundant power, 20.5 Watts maximum*
Fuse Protection (internal)	Internal Non-replaceable Fuse
Mounting	2-wide CHARM I/O Carrier
Communication	Redundant Ethernet connections via CHARM I/O Carrier
Network Addressing	Auto Assigned during commissioning
LED Indicators:	
Green – Power	Indicates DC power is applied.
Red – Error	Indicates an error condition.
Green – Active/Standby	Indicates operating mode of each CIOC
Yellow flashing – Pri./Sec. CN	Indicates valid control network communication.

* Actual CIOC Output to CHARMs is dependent on number of installed CHARMs

IS CHARM Baseplate	
Number of channels per baseplate	12
Number of base plates per CIOC	8
Addressing	One Address Plug (1 through 8)
Terminal blocks	Standard IS Terminal Block (Light Blue)
Shield connections	1 Screw Cage terminal per channel, plus 1 for cable shield 2.1 -0.32 mm ² / 14 – 22 AWG Gold plated connectors for shield continuity
Wire strip length	7 - 9 mm / 0.28 – 0.36 in.
Mounting	DIN rail Latch to T-type rail
Specifications for Baseplate Termination, Top and Bottom	
Shield Drain wire connections	2 Screw Cage Terminals 2.1 -0.32 mm ² / 14 – 22 AWG
Wire strip length	7 - 9 mm / 0.28 – 0.36 in.
Specifications for Baseplate Extenders, Top and Bottom	
Primary Bus connection	9-pin D-shell, Primary RS-485 communications bus Primary 24 VDC field power Primary CHARM power
Secondary Bus connection	9-pin D-shell, Secondary RS-485 communications bus Secondary 24 VDC field power Secondary CHARM power
Specifications for Extender Cables	
Maximum bus length (including Baseplates)	10 m (32.8 ft)
Available Cable lengths	2 m, 1 m, 0.5 m (6.7 ft, 3.3 ft, 1.6 ft)

Specifications for Standard IS Terminal Block	
Number of connections	4 Screw Cage terminals 2.1 -0.32 mm ² / 14 – 22 AWG
Strip length	7 - 9 mm / 0.28 – 0.36 in.
Maximum Current	Determined by IS CHARM type installed
Color	Light Blue
Specifications for Address Plug Terminal Block	
Number of connections	none
Color	Black

IS Analog Input CHARMS

Specifications for IS AI 4-20 mA HART CHARM	
Sensor Types	4-20 mA with or without HART Supports 2-wire and 4-wire device types
Nominal signal range (span)	4-20 mA, (0-20 mA optional)
Full signal range	0 to 22 mA
Input Impedance	< 303 Ω
Field Power (2-wire)	16.0 V(min) at 20 mA
Accuracy over temperature range	0.1% of span (0-60° C) 0.15% of span (over -40 -70° C)
Repeatability	0.05% of span
Resolution	16 bit A/D converter
Calibration	None required
DC/50/60 Hz Common mode rejection	N/A
Field Circuit (2-wire Transmitter) - Voltage Uo - Current Io - Power Po	(Connect between field terminals 3+, 4-) - 27.3 V - 93 mA - 635 mW (linear Characteristic)
Field Circuit (2-wire Current Source) - Voltage Uo - Current Io - Voltage Ui - Current Ii - Current Pi	(Connect between field terminals 4+, 2-) - 27.3 V - negligible - 28 V - 110 mA - 2.12 W
CHARM power req.	45.71 mA max @ 24 VDC (1097 mW)
CHARM Heat Dissipation	615 mW
HART support	HART v7 pass-through for AMS HART v7 variable and device status available to control
HART data update rates	1.5 seconds

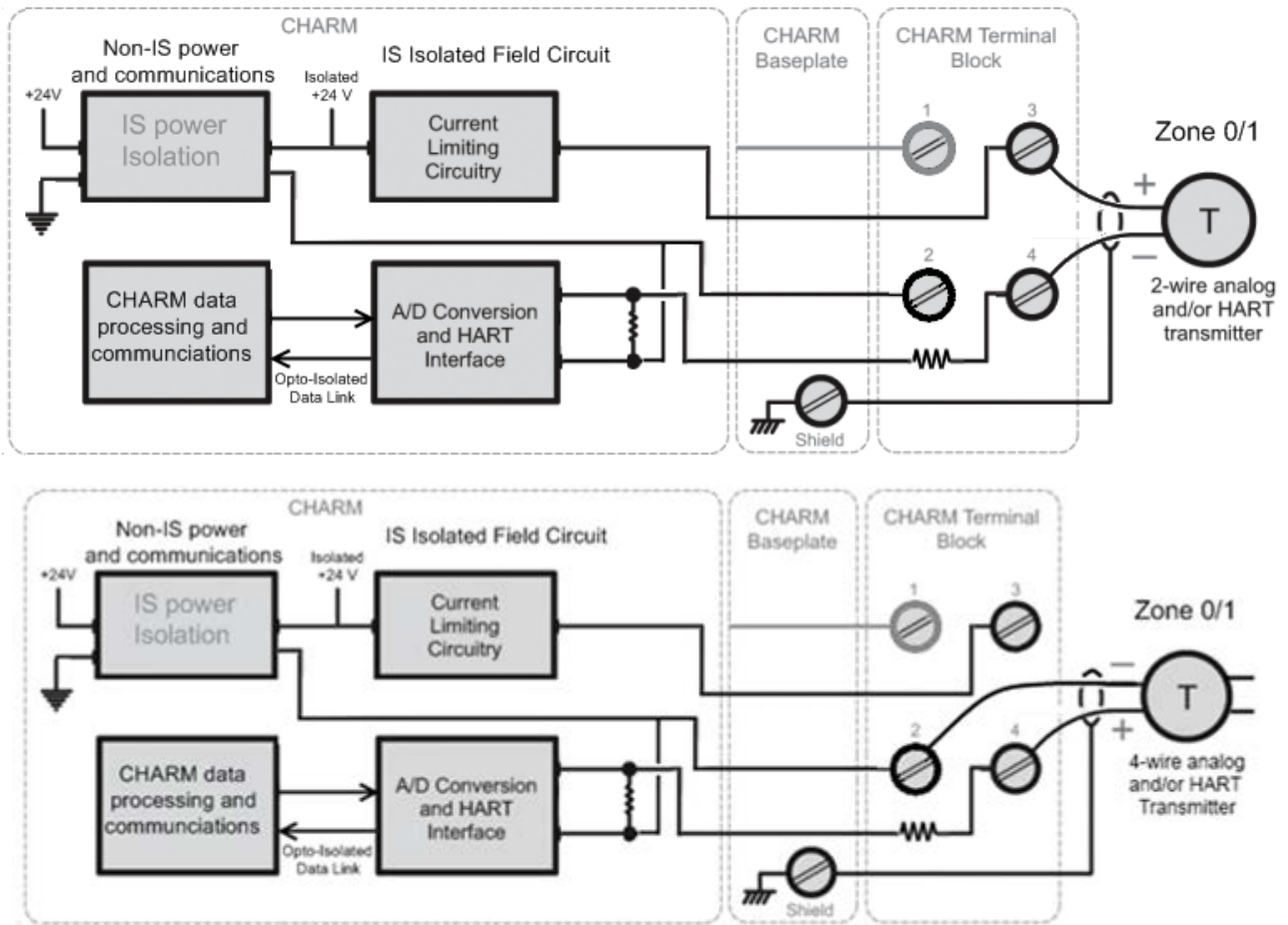

Simplified Circuit and Connection Diagrams for IS AI-Charm 4 to 20 mA HART Two Wire and Four Wire transmitters

IS Analog Output CHARMS

Specifications for IS AO 4-20 mA HART CHARM	
Sensor Types	4 to 20 mA with or without HART
Nominal signal range (span)	4 to 20 mA,
Full signal range	0 to 22 mA
Load Resistance	750 Ohm max.
Voltage to Load	15 V (min) @ 20 mA
Accuracy over temperature range	0.25% of span (0 to 60 °C) 0.3% of span (-40 to 70 °C)
Resolution	14 bits min
Calibration	None required
Open-Loop Detection	0.75 mA +/- 0.25 mA
Field Circuit (2-wire Transmitter)	(Connect between field terminals 3+, 4-) - Voltage Uo - Current Io - Power Po
CHARM power req.	45.7mA mA max @ 24 VDC (1095 mW)
CHARM Heat Dissipation	615 mW
HART support	HART v7 pass-through for AMS HART v7 variable and device status available to control
HART data update rates	1 s

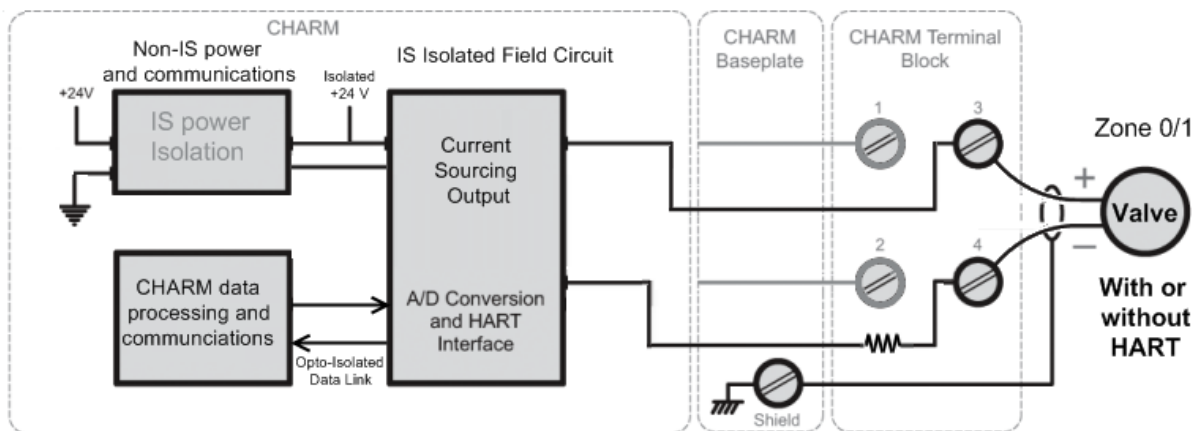

Simplified Circuit and Connection Diagram for IS AO HART CHARM

IS Discrete Input CHARMs

Specifications for IS DI NAMUR CHARM	
Sensor Types	NAMUR Sensors, Dry Contacts
Detection level for On	> 2.1 mA
Detection level for Off	< 1.2 mA
Wetting Voltage	7.0 to 9.0 from 1kOhm ($\pm 10\%$)
Fault Detection capable	NAMUR Sensors or field resistor pack
<ul style="list-style-type: none"> - Short Circuit - Open Circuit 	<200 Ohm >40 KOhm
Configurable channel types:	
<ul style="list-style-type: none"> • Discrete input • Pulse Count 	Dry contact (<2 Hz state changes) Max 10 kHz (25 μ sec min pulse width)
Field Circuit	(Connect between field terminals 3+, 4-)
<ul style="list-style-type: none"> - Voltage Uo - Current Io - Power Po 	- 11.55 V - 13 mA - 37.54 mW (linear Characteristic)
CHARM power req.	20.3 mA max @ 24 VDC (488 mW)
CHARM Heat Dissipation	488 mW

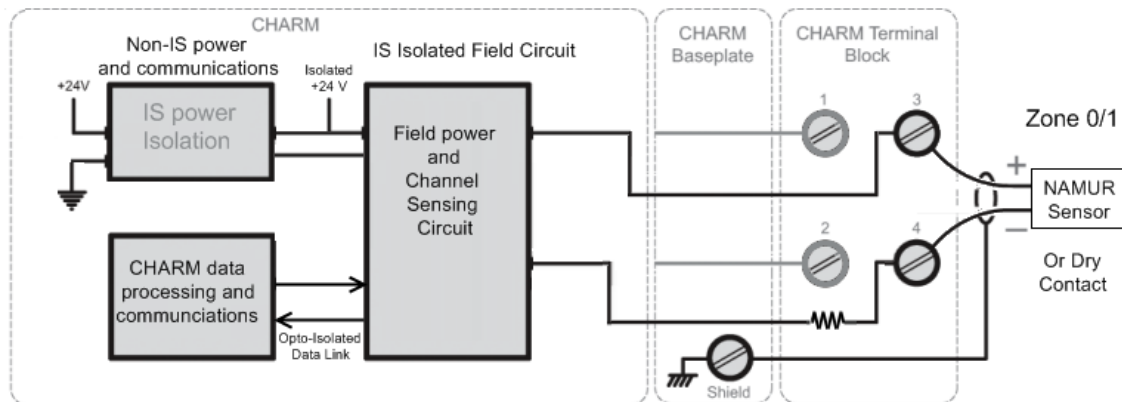

Simplified Circuit and Connection Diagram for IS DI NAMUR CHARM

IS Discrete Output CHARMS

Specifications for DO 24 VDC High-Side CHARM	
Output Range	22 V 11 V @ 45 mA 25 V maximum
Configurable output behavior	Latching Output Momentary (pulse duration from 50 ms to 100 s) Continuous Pulse (Period from 50 ms to 100 s)
Minimum Output Voltage	22 V (open Circuit) 11 v at 45 mA
Line Fault Detection	Short Circuit < 100 Ohms load Open Circuit > 25 KOhms load
Field Circuit	(Connect between field terminals 3+, 4-)
<ul style="list-style-type: none"> - Voltage Uo - Current Io - Power Po 	<ul style="list-style-type: none"> - 27.54 V - 110 mA - 760 mW (linear Characteristic)
CHARM power req.	78.5 mA max @ 24 VDC (1883 mW)
CHARM Heat Dissipation	995 mW

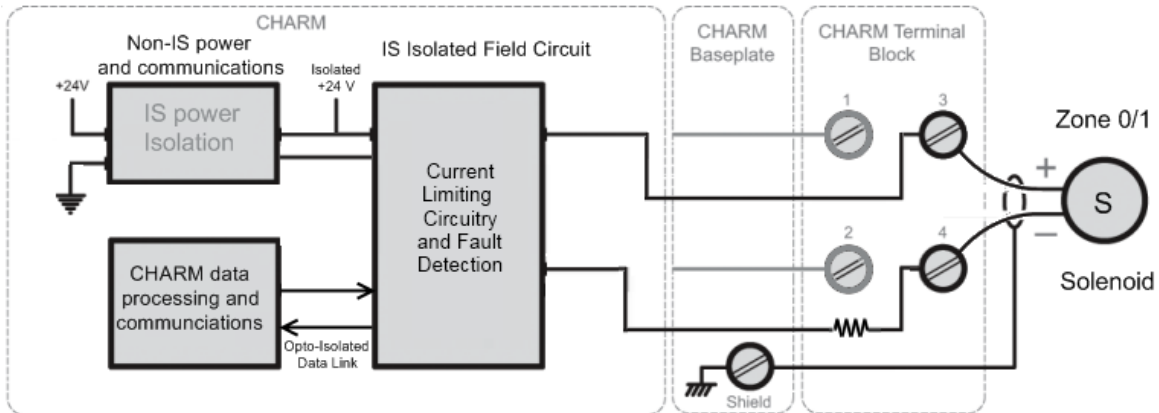

Simplified Circuit and Connection Diagram for IS DO 45 mA CHARM

System Compatibility

IS CHARM I/O hardware requires:

- SX or SD Plus controllers

S-series and M-series controllers can be installed on the same DeltaV Area Control Network in v11 and beyond. Control modules can be assigned to either series of controller and inter-controller references are fully supported between controller series

- CHARM I/O Card

IS CHARMs installed on IS CHARM baseplates can be connected to a CHARM I/O Card carrier, using a baseplate separator and a special fuse in each of the two the power supply lines of the CHARM I/O carrier.

- Non-IS CHARM Baseplates

Non-IS CHARM baseplates can be extended with IS CHARM baseplates, using a baseplate separator.

- IS CHARM Baseplates

IS CHARM baseplates cannot be extended with non-IS CHARM Baseplates.

- Baseplate Extender

IS CHARM baseplates can be connected to CHARM baseplate extenders using baseplate separators.

- Baseplate Terminator

IS CHARM baseplates can be connected to CHARM baseplate terminators using baseplate separators.

Refer to installation instructions for rules governing IS wiring.

Certifications

The following certifications are available on IS CHARMs:

■ **CE:**

- EMC- EN 61326-1:2006

■ **FM:**

- FM 3600, Nov. 1998
- FM 3610, Jan 2010
- FM 3611, Dec. 2004
- FM 3810, Jan 2005
- ANSI/ISA 60079-0, Oct 2009
- ANSI/ISA 60079-15, Jul 2009

■ **CSA:**

- CSA-C22.2 No 157, 1992
(Reaffirmed 2006)
- CSA C22.2 No. 213-M1987, 1987
(Reaffirmed 2008)
- CSA C22.2 No. 61010-1, 2004
(Reaffirmed 2009)
- CAN/CSA-E60079-0, 2007
- CAN/CSA-E60079-11, 2002
(Reaffirmed 2006)
- CAN/CSA-E60079-15, March 2002
(Reaffirmed 2006)

■ **ATEX:**

- ATEX 94/9/EC
- EN60079-0: 2009
- EN60079-11:2007
- EN60079-15:2010
- EN60079-26:2007
- EN61241-0:2006
- EN61241-11:2006

■ **IEC-Ex:**

- IEC60079-0:2007
- EC60079-11:2006
- IEC60079-15:2010
- IEC60079-26:2006
- IEC61241-0:2004
- IEC61241-11:2005

Certifications (Pending)

IS CHARMs will be submitted for the following certifications

■ **Marine Certifications:**

IACS E10:2006 Rev.5 Control, Protection & Safety

- ABS Certificate of Design Assessment
- Bureau Veritas Certificate
- DNV Marine Certificate
- Lloyds Register

■ **GOST Hazardous Area certification Zone 2 (Russian)**

Hazardous Area/Location:

IS CHARMs can be installed and used based on the following Standards

■ **FM (USA):**

Installation:

- Class I, Division 2, Groups A, B, C, D, T4
- Class I, Zone 2 AEx nAc IIC

Field Circuits:

- Class I, Division 1, Groups A, B, C, D
- Class II, Division 1, Groups E, F, G
- Class III
- Class I, Zone 0 [AEx ia] IIC

■ **cFM (Canada):**

Installation:

- Class I, Division 2, Groups A, B, C, D, T4
- Class I, Zone 2 Ex nA IIC

Field Circuits:



- Class I, Division 1, Groups A, B, C, D
- Class II, Division 1, Groups E, F, G
- Class III
- Class I, Zone 0 [Ex ia] IIC

■ **ATEX:**

Installation:

-  II 3 G Ex nAc IIC

Field Circuits:

-  II (1) G [Ex ia] IIC
-  II (1) D [Ex ia] IIIC

■ **IEC-Ex:**

Installation:

- Ex nAc IIC

Field Circuits:

- [Ex ia Ga] IIC
- [Ex ia] IIIC

Regarding the Installation instructions please refer to the following Documents:

- ATEX/IECEx Installation Instructions IS-CHARM Subsystem* 12P6523 Rev. C
- Control Drawing DeltaV™ IS-CHARMs Subsystem* 12P6122 Rev. C
- Control Drawing DeltaV™ IS-CHARMs* 12P6123 Rev. B

IS CHARM ENTITY PARAMETERS

Model Typ	Field Terminals	Voc (U0) [V]	Isc (I0) [mA]	Vmax (Ui) [V]	I _{max} (Ii) [mA]	GROUPS	Ca (C0) [nF]	La (L0) [mH]
IS AI 4-20 mA HART	3, 4	27.3	93	--	--	A,B IIC	88	4.11
						C,E IIB	683	16.44
						D,F,G IIA	2280	32.88
	4, 2	27.3	negligible	28	110	Pi	2.12 W	
IS AO 4-20 mA HART	4, 3	27.0	93	--	--	A,B IIC	90	4.11
						C,E IIB	705	16.44
						D,F,G IIA	2330	32.89
IS DI NAMUR	4, 3	11.55	13	--	--	A,B IIC	1590	210.4
						C,E IIB	10800	841.55
						D,F,G IIA	43000	1680
IS DO 45 mA	4, 3	27.54	110	--	--	A,B IIC	86	2.94
						C,E IIB	668	11.75
						D,F,G IIA	2220	23.51

Ordering Information

CHARM I/O CARD	
Description	Model Number
Redundant CIOC with Copper Ethernet , includes redundant pair of CHARM I/O Cards, CHARM I/O Carrier with Screw Terminals, Copper I/O Ports, a Baseplate Identifier and a Baseplate Separator	SE6501T01
Redundant CIOC with fiber optics Ethernet , includes redundant pair of CHARM I/O Cards, CHARM I/O Carrier with Screw Terminals, Fiber-Optic I/O Ports, a Baseplate Identifier and a Baseplate Separator	SE6501T02
Redundant CIOC , includes 2 CHARMS I/O Cards, (Order these with standard cabinets)	SE6502
IS CHARM Baseplates	
Description	Model Number
IS CHARMS Baseplate Assembly with Standard IS CHARM Terminal Blocks , includes IS CHARMS Baseplate, IS CHARM Address Terminal Block, 12 IS CHARM Standard Terminal blocks and a Baseplate Separator	SE4608T01
CHARM I/O Baseplate Address Plugs	
Description	Model Number
CHARMs Addressing Plugs , includes Address Plugs 1 through 8	SE4602
CHARM I/O Baseplate Extender, Terminator & Cables	
Description	Model Number
CHARMs Baseplate Extender with Cable Connectors, Top (Male) includes a Baseplate Identifier and a Baseplate Separator	SE4603T05
CHARMs Baseplate Extender with Cable Connectors, Bottom (Female) includes a Baseplate Identifier and a Baseplate Separator	SE4603T06
CHARMs Baseplate Terminator, Top (Male) includes a Baseplate Identifier and a Baseplate Separator	SE4604T03
CHARMs Baseplate Terminator, Bottom (Female) includes a Baseplate Identifier and a Baseplate Separator	SE4604T04
CHARMs Baseplate Cables , includes two 0.5 m cables	SE4605T02
CHARMs Baseplate Cables , includes two 1 m cables	SE4605T03
CHARMs Baseplate Cables , includes two 2 m cables	SE4605T04

Each vertical DIN rail requires a DIN Rail stop to lock baseplates in position. Order VE4054DRS, which is a box of 5.

Prerequisites

S-Series IS Electronic Marshalling hardware requires DeltaV v11.3.1 or later software.

Ordering Information

IS CHARM I/O Labeling	
Description	Model Number
Channel Identifier Labels for Intrinsically-Safe CHARM Baseplates; Package of 8	SE4609T01
IS CHARMS	
Description	Model Number
IS DI NAMUR	SE4305T01
IS DO 45 mA	SE4306T01
IS AI 4-20 mA HART	SE4307T01
IS AO 4-20 mA HART	SE4308T01

Prerequisites

S-Series IS Electronic Marshalling hardware requires DeltaV v11.3.1 or later software.

IS CHARM FUSE	
Description	Model Number
Fuse Holder and Fuse Assembly for 24VDC Power Supply of CHARM I/O CARD	SE4610T01*

* Two of these Fuse Assemblies have to be ordered with any SE6501T01 or SE6501T02, when used with IS CHARM baseplates

A	4.04" (102.5 mm)	M	1.77" (45 mm)
B	1.04" (26.5 mm)	N	1.28" (32.5 mm)
C	2.10" (53 mm)	P	0.40" (10.5 mm)
D	3.13" (79.5 mm)	R	1.48" (37.5 mm)
E	4.17" (106 mm)	S	0.30" (8 mm)
F	2.66" (67.5 mm)	T	0.80" (20.5 mm)
G	3.00" (76 mm)	U	∅ 0.33" (8.5 mm)
H	3.70" (94.2 mm)	W	0.1" (2.5 mm)
J	2.07" (52.5 mm)	X	3.17" (80.5 mm)
K	0.30" (8 mm)	Z	∅ 0.17" (4.4 mm)

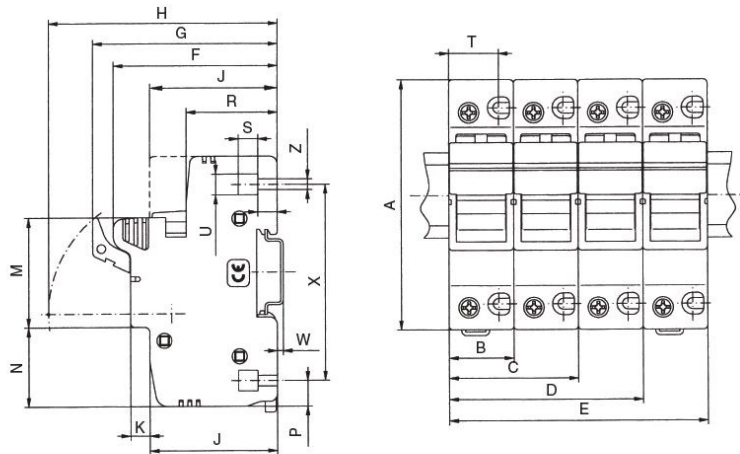

Outside Dimensions of the Fuse Holder

Spare part ordering Information

SPARE PARTS	
Description	Model Number
IS Charm Baseplate Separator (Qty. 1)	KL4510X1-CA1
Replacement Fuse for SE4610T01 Fuseholder Assembly	KL4510X1-FA1
Replacement Fuseholder for SE4610T01 Fuseholder Assembly	KL4510X1-GA1

To locate a sales office near you, visit our website at:
www.EmersonProcess.com/DeltaV
 Or call us at:
 Asia Pacific: 65.777.8211
 Europe, Middle East: 41.41.768.6111
 North America, Latin America: +1 800.833.8314 or
 +1 512.832.3774

For large power, water, and wastewater applications
 contact Power and Water Solutions at:
www.EmersonProcess-powerwater.com
 Or call us at:
 Asia Pacific: 65.777.8211
 Europe, Middle East, Africa: 48.22.630.2443
 North America, Latin America: +1 412.963.4000

© Emerson Process Management 2012. All rights reserved. For Emerson Process Management trademarks and service marks, go to:
<http://www.emersonprocess.com/home/news/resources/marks.pdf>.

The contents of this publication are presented for informational purposes only, and while every effort has been made to ensure their accuracy, they are not to be construed as warranties or guarantees, express or implied, regarding the products or services described herein or their use or applicability. All sales are governed by our terms and conditions, which are available on request. We reserve the right to modify or improve the design or specification of such products at any time without notice.



www.DeltaV.com

