

S-series DeviceNet Interface Card



The DeltaV™ S-series DeviceNet Interface Cards provide the solutions for interfacing to discrete actuators and sensors.

- Offers freedom to choose appropriate bus for application
- Supports standard device-level busses
- Reduces wiring costs
- Features native controller level interface
- Able to mix and match bus technologies to meet application requirements

Introduction

The DeltaV™ DeviceNet interface is a field-proven interface for discrete actuators and sensors. It is easy to install, reliable, and simple to use.

High data throughput, simple installation, good diagnostic capabilities and error-free proven transmission technology make the DeltaV DeviceNet a good interface solution for complex devices.

Benefits

Offers freedom to choose appropriate bus for application. The DeltaV system supports sensor, device, and fieldbus technologies. Choose the most efficient and effective DeltaV interface for your needs, based on your operating philosophy and plant constraints.

Supports standard device-level busses. The DeltaV system gives a seamless interface with CENELEC or IEC standard device busses. Our support of standards ensures your freedom to use the devices you prefer.

Reduces wiring costs. The DeltaV DeviceNet interface decreases the number of wiring diagrams and cable and clamp labeling needed. The modular designs reduce network creation time. And, it takes less time to install and test the DeviceNet than Classic I/O for the equivalent number of discrete signals.

Features native controller-level interface. DeltaV DeviceNet cards communicate directly to the controller, without the need for a serial interface and other intermediate converters. This greatly simplifies the configuration and maintenance. You can rely on DeltaV DeviceNet cards to provide real-time, consistently accurate inputs and outputs. As the network of field devices grows, maintenance remains constant.

Able to mix and match bus technologies to meet application requirements. The DeltaV system makes it easy to configure and activate the devices. For devices not in the library, users can add devices and customize signal labeling according to specific plant standards.

DeviceNet, AS-i bus, Profibus DP, FOUNDATION fieldbus, HART, and traditional I/O can be easily intermixed on an I/O card basis on the same DeltaV controller. The same configuration, diagnostic, and operator interface techniques are used to configure the system.

Product Description

The DeltaV DeviceNet card uses standard DeviceNet cabling. The interface is based on the master/slave principle. Sixty-one slaves may run on a cable.

One DeviceNet segment is supported on a single interface. Temperature and certification specifications are the same as other DeltaV I/O.

The DeviceNet transmission technology is easy to install. The bus structure permits addition and removal of stations or step-by-step commissioning of the system without influencing the other stations. Future expansions have no effect on stations already in operation.

Transmission speeds between 125 kbit/sec and 500 kbit/sec can be selected. One unique transmission speed is selected for all devices on the bus when the system is commissioned.

It should be noted that signals connected to the controller through the DeviceNet interface are not as fast as signals that are directly wired to DeltaV discrete I/O cards.

Although each signal brought into the controller via DeviceNet counts as a DST, and is handled in the same manner as directly connected I/O in the control strategy, the effect of device communication failure and recovery must be taken into account. DeviceNet devices may also support diagnostic information, which is made available in the Diagnostics explorer, and as such does not consume a DST. The number of DSTs per connected device can vary from 4 to several hundred. A motor starter, for example, may consume 4 to 5 DSTs, and a remote I/O island will consume as many DSTs as there are I/O connections. Performance of the DeviceNet segment will be a function of the number of devices connected and the baud rate; typically, an additional 80–100mS latency will be introduced rather than directly connecting the signal.

DeviceNet Slave

A DeviceNet slave is a peripheral device (I/O device, drive, HMI, valve, etc.) that collects input information and sends output information to the master. There are also devices that supply only input or only output information. The amount of input and output information depends on the device type.

Only slave devices that support polling may be used. The DeltaV DeviceNet card (master) cyclically reads the input information from the slaves and cyclically writes the output information to the slaves. In addition to cyclic user data transmission, DeviceNet provides powerful functions for diagnostics and configuration.

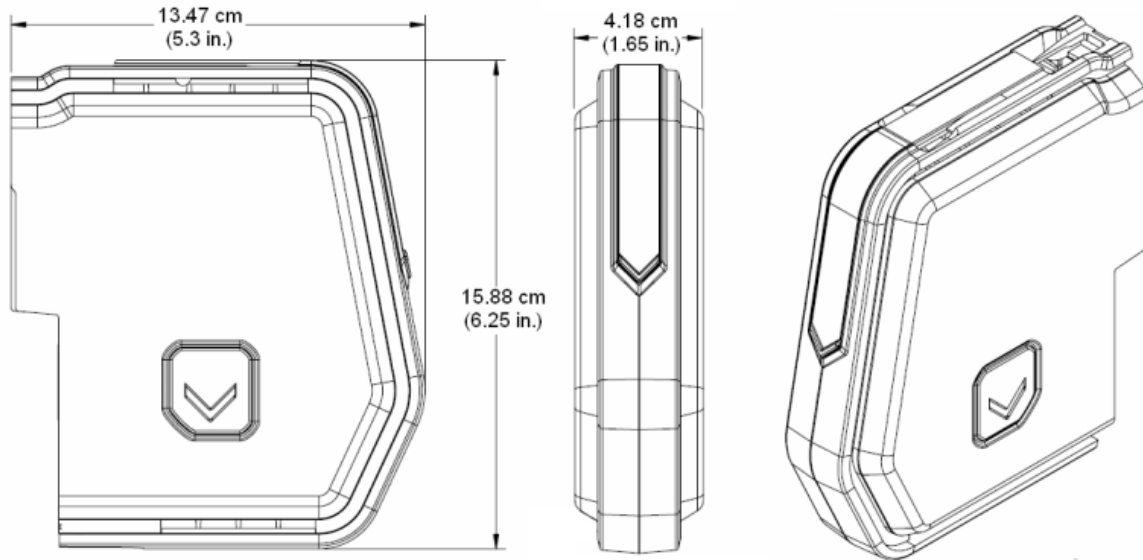

S-series DeviceNet Card dimensions

Hardware Specifications

DeviceNet transmission speeds and cable lengths			
Baud rate (kbit/sec)	125	250	500
Distance/segment	500m	250m	100m

S-series DeviceNet Interface Specifications	
Category	Specifications:
Number of ports	1
Number of Devices	61
Environmental Specifications	
Storage Temperature	-40 to 85 °C (-40 to 185 °F)
Operating Temperature	-40 to 70 °C (-40 to 158 °F)
Relative humidity	5 to 95% , non-condensing
Airborne contaminants	ISA-S71.04-1985 Airborne Contaminants Class G3 Conformal coating
Protection rating	IP 20, NEMA 12
Shock	10 g ½-sine wave for 11 ms
Vibration	1 mm peak-to-peak from 5 to 13.2 Hz; 0.7 g from 13.2 to 150 Hz

DeviceNet Interface Specifications	
Number of ports	1

Certifications

The following certifications are available on on the S-series DeviceNet Interface card.

■ CE:

- EMC- EN 61326-1:2006
- LVD- EN 61010-1:2001

■ CSA:

- CLASS 2252 05 - PROCESS CONTROL EQUIPMENT:

CAN/CSA-C22.2 No. 0-M91 General Requirements-
Canadian Electrical Code, Part II

CAN/CSA-C22.2 No. 61010-1-04 Safety
Requirements for Electrical Equipment for
Measurement, Control, and Laboratory Use,
Part 1: General Requirements

The following certifications have been submitted for Hazardous Locations and for Marine applications. Please verify with the appropriate certifying agency for a specific list of approved components

■ CENELEC Zone 2 ATEX/IEC EX

EN 60079-15:2005

Certifying agency: Nemko

Certificate Number: TBD

Refer to document TBD

*"DeltaV™ Scalable Process System Zone 2
Installation Instructions"*

■ FM Approval

Class 1 Division 2 Hazardous Locations

Certifying agency: FM Approvals

Certificate Number: TBD

Refer to document TBD

*"DeltaV™ Scalable Process System Class 1
Division 2 installation Instructions"*

■ Marine Certifications:

IACS E10:2006 Rev.5 Control, protection &
Safety

- ABS Certificate of Design Assessment
- Bureau Veritas Certificate
- DNV Marine Certificate
- Lloyds Register

■ GOST Hazardous Area certification Zone 2 (Russian)

Other country specific certifications may also be available. Verify with your local Emerson sales office to confirm any certification requirements not listed here.

Complies with NAMUR NE21 per DeltaV Digital
Automation System NAMUR NE21 Installation Instructions
12P2822.

Ordering Information

Description	Model Number
S-series DeviceNet Interface Card	SE4016

To locate a sales office near you, visit our website at:
www.EmersonProcess.com/DeltaV
Or call us at:
Asia Pacific: 65.777.8211
Europe, Middle East: 41.41.768.6111
North America, Latin America: +1 800.833.8314 or
+1 512.832.3774

For large power, water, and wastewater applications
contact Power and Water Solutions at:
www.EmersonProcess-powerwater.com
Or call us at:
Asia Pacific: 65.777.8211
Europe, Middle East, Africa: 48.22.630.2443
North America, Latin America: +1 412.963.4000

© Emerson Process Management 2011. All rights reserved. For Emerson Process Management trademarks and service marks, go to:
<http://www.emersonprocess.com/home/news/resources/marks.pdf>.

The contents of this publication are presented for informational purposes only, and while every effort has been made to ensure their accuracy, they are not to be construed as warranties or guarantees, express or implied, regarding the products or services described herein or their use or applicability. All sales are governed by our terms and conditions, which are available on request. We reserve the right to modify or improve the design or specification of such products at any time without notice.

