

S-series Electronic Marshalling

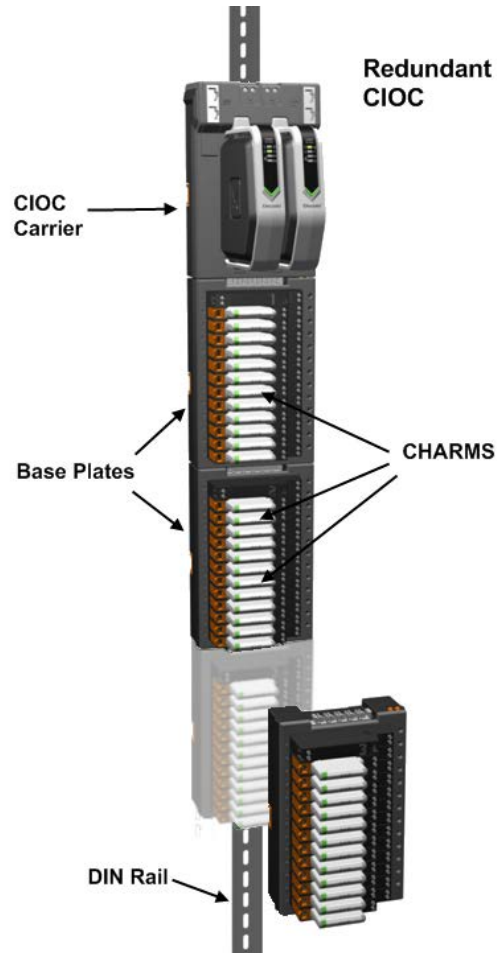

The DeltaV™ CHARM I/O Card (CIOC) with CHARMS

- I/O anywhere you need it
- Single channel granularity
- Reduces installed cost of system
- Fully redundant architecture
- Field mounted capable hardware
- Plug and play I/O

Introduction

DeltaV™ S-series Electronic Marshalling delivers a new level of control system I/O performance with unprecedented flexibility and ease of use. The CHARM I/O card (CIOC) supports up to 96 individually configurable channels and is designed specifically for multi-core home run cables in centrally located marshalling cabinets. It can also be installed in field junction boxes to further reduce system design and installation costs. All communications are completely redundant from the channel (CHARM) to the DeltaV S-series controller.

Benefits

I/O anywhere you need it. DeltaV CHARM I/O Card (CIOC) provides an unprecedented flexibility in control system I/O topology. Using standard Ethernet infrastructure hardware you can add I/O anywhere you need it. From a local I/O cabinet to remote enclosures miles away, simply install the hardware and connect it to the DeltaV control network. Each I/O card can serve I/O signals to any four controllers in the system with 50 ms updates for fast, reliable control.

Single channel granularity. The CHARM I/O architecture allows each individual channel to be characterized for the requirements of the field device. Any instrument signal can be wired to any terminal block. The channel is then electronically marshalled by installing the appropriate CHARM and assigning the channel to one of four controllers. Home run multi-core instrument cables can be landed in order on a series of CHARM terminal blocks without concern for signal types.

Reduces installed cost of system. DeltaV Electronic Marshalling helps reduce overall system costs by eliminating internal cabinet cross wiring, reducing overall footprint, simplifying I/O channel assignments, and reducing FAT activities. Electronic Marshalling provides separation between I&E hardware installation schedules and control strategy development. Wiring can begin earlier knowing any late changes can be done without lifting a wire. Separation of the controller and I/O allows more efficient cabinet designs and accommodates late scope changes can add I/O anywhere. Adding additional control capacity does not require re-wiring I/O. Simply assign the control modules and their I/O signals to the new controller, without lifting a wire.

Fully redundant communications. The CIOC architecture is fully redundant. It starts with the two I/O cards on a carrier. The carrier has redundant communication modules for primary and secondary network connections. There are two 24 VDC input power connections. The carrier connects to the CHARMs baseplates and provides redundant power and communication buses to the CHARMs. Everything is redundant down to the individual channel.

Field mounted capable hardware. All components of the CIOC are rated for installation in Class 1/Div 2 or Zone 2 hazardous locations. The extended operating temperature ranges and G3 environment rating allows them to be installed in field mounted junction boxes. This further reduces the footprint required in central equipment rooms, as well as reduces the overall wiring infrastructure of traditional multi-core instrumentation cable.

Plug and Play I/O. The DeltaV CIOC has been designed for ease of use, both in physical installation and its software tools. Components snap together with secure DIN-rail latches and interlocking carrier connectors. Attach a series of 96 I/O channels to a DIN-rail in a matter of minutes. Insert the CHARMs and auto sense the node to create the I/O definition automatically in your DeltaV configuration database. CHARMs use a self keying system to automatically set a channel for a specific CHARM type. Users cannot mistakenly insert a CHARM into the wrong terminal block. Assign all, one or any number of channels to a controller with a simple click or drag and drop.

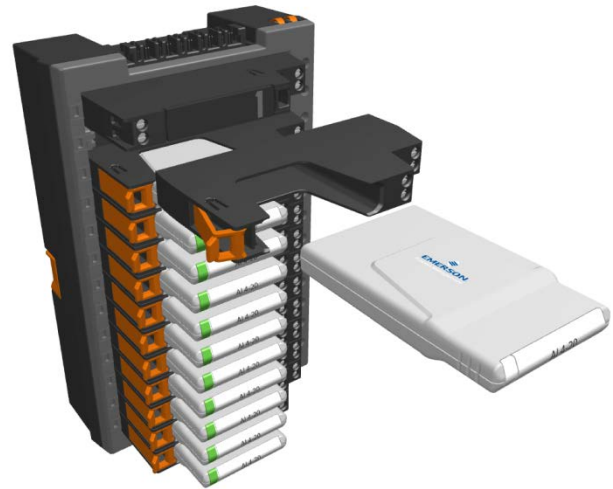

CHARM and Terminal Block installation.

Field power is provided through a redundant 24VDC bus to each CHARM, with up to 100 mA per CHARM. Higher current Discrete Channels can be powered through integrated power injection bus local to each CHARM Baseplate.

Product Description

Electronic Marshalling hardware includes:

- CHARM I/O Carrier (DIN rail mounted and supports redundant pair of CHARM I/O Cards, redundant 24 VDC power connectivity, and redundant Ethernet communication modules)
- CHARM I/O Card (provides communication between CHARMS and the Ethernet I/O network to S-series controllers)
- CHARM Base plate (DIN rail mounted with interleaving power and bus connectors. Supports 12 CHARMS and their terminal blocks, as well as connection for injected field power)
- CHARM Terminal Block (removable terminal block providing terminal connections to field wiring and physical latch for CHARM)
- CHARMS (Characterization Module for each field signal. Provides basic analog to digital conversion and signal isolation to the redundant communication bus)
- Cable Extenders that provide flexibility in carrier mounting.
- I/O bus termination (provides bus terminations for redundant I/O bus)
- Labeling features for baseplate and channel identification.



CHARM I/O Card (CIOC) with CHARMS

The CHARM I/O card carrier is mounted to the top of a vertical DIN rail and up to eight CHARM Baseplates are mounted below it, snapping easily to the DIN rail as they are connected to each other. The bus termination assembly is attached at the bottom. A standard DIN-rail lock is used to keep the entire assembly in place.

A pair of CHARM I/O Cards installs on the carrier and communicates over a redundant Ethernet network with up to 4 controllers, allowing great flexibility and ease of system expansion. Communication modules are available for copper and fiber optic media.

Each baseplate is ordered with 12 terminal blocks: standard terminal blocks or fused injected power terminal blocks. Electronic Marshalling eliminates the need to partition the I/O wiring to specific channels based on signal type. Simply connect field signal multi-cores in an orderly fashion as desired. Install the appropriate CHARM to complete the field circuit and the signal is ready to be used by any one of 4 S-series controllers. No cross-wiring required.

Each CHARM acts as a circuit protection device and field wiring disconnect. Signals are inherently current limited to protect against wiring faults to ground. Each CHARM provides surge protection to meet industry standards in the area of EMC. Under extreme overvoltage conditions due to incorrect field wiring, the CHARM will act as a fuse to protect adjacent channels. Signal faults are thus isolated to the single CHARM.

CHARMs can be partially ejected to a locked position that disconnects the field wiring from the system to perform field maintenance actions or to remove power to a field device. Activating the CHARM latch ejects the CHARM to the detent position. Closing the latch locks the CHARM in place and isolates the field wiring for field work..



CHARM Latch mechanism

Baseplate extenders and cables provide great flexibility to the CHARM installation in existing cabinets or in custom enclosures. Cables are redundant, each carrying 24 VDC field power, 6.3 VDC CHARM power and one of the communication busses.

Bus termination provides added robustness for the communication bus and is installed at the end of the physical bus.

Label features are available to identify channel usage and Baseplate identification to help with maintenance.

CHARMs can be added to any existing baseplate position and autosensed online. Additional CIOC's can be added online.

CHARM Types

A variety of analog and discrete CHARMs are available to meet your specific requirements. The following CHARMs are available starting with v11.3.x:

- AI 4-20 mA HART
- RTD
- Thermocouple / mV
- AI 0-10 VDC Isolated
- AO 4-20 mA HART
- DI NAMUR
- DI 24 VDC low-side sense (dry contact)
- DI 24 VDC Isolated
- DI 120 VAC Isolated
- DI 230 VAC Isolated
- DO 24 VDC High Side
- DO 100mA Energy Limited
- DO 24 VDC Isolated
- DO VAC Isolated

All CHARMs have a bi-color Power/Integrity LED that indicates the health of the CHARM. The indications provide clear, actionable instruction to the maintenance personnel.

- Green Solid: Normal Operation
- Green Blink: Normal awaiting configuration
- Red Blink: Fault detected on wiring
- Red Solid: Internal Fault detected

S-series Electronic Marshalling

Discrete CHARMs have a Yellow LED to indicate the state of the field signal. (On = circuit is energized)

All CHARMs meet ISA 71.04-1985 severity level G3 (harsh) corrosion specifications.

Discrete input CHARMs support pulse counters with a maximum frequency of 10 KHz.

I/O Terminal Block Options

There are 4 different I/O terminal blocks available to meet the wiring needs of field signals.

- Standard Terminal Block
- Injected Power Terminal Block
- Fused Injected Power Terminal Block
- Relay Output Terminal Block

The Standard Terminal block can be used with all CHARMs types. For traditional wiring of field instrumentation, the CHARMs provide loop power through the internally distributed 24 VDC field power. Refer to specific CHARM specifications for wiring information.

The Injected Power Terminal block is designed to be used with the Isolated discrete CHARM types, creating a system powered circuit that can deliver up to 1 amp (DC) of power on discrete output channels. Each baseplate has a local power bus that can be connected to 24 VDC or 120/230 VAC through the injected power input terminals, located on the Address Plug terminal block. Injected power Terminal Blocks connect to this power bus provide system power to the field circuit through the isolated CHARM. You can combine isolated and system powered circuits on the same baseplate, however, all system powered channels on a baseplate share the same power source.

The Injected Power Terminal block has been replaced by the Fused Injected Power Terminal block, see below:

The Fused Injected Power Terminal block includes a 2A field replaceable fuse and is designed to be used with the Isolated discrete CHARM types, creating a system powered circuit that can deliver up to 1 amp (DC) of power on discrete output channels. Each baseplate has a local power bus that can be connected to 24 VDC or 120/230 VAC through the injected power input terminals, located on the Address Plug terminal block. Fused Injected power Terminal Blocks connect to this power bus to provide system power to the field circuit through the isolated CHARM. You can combine isolated and system powered

circuits on the same baseplate, however, all system powered channels on a baseplate share the same power source.

The Relay Output Terminal Block is designed for high output current applications and requires the DO 24 VDC High-side CHARM to drive the relay coil. The Relay Output Term blocks provide a normally open and normally closed contact with the following ratings:

- 28.8 VDC at 5 A switching current
- 48 VDC at 0.4 A switching current
- 250 VAC at 5 A switching current

Although any signal type can be installed in any location on the CHARM baseplates, it is recommended that AC voltage circuits be separated from low voltage signals to comply with safety recommendations and to mitigate induced noise in the signals. Standard Terminal blocks, Fused or not Fused Injected Power terminal blocks and Relay Output Blocks can be used on the same carrier, typically to allow the use of DO 24 VDC isolated CHARMs on higher wattage devices along side of standard 24 VDC instrumentation signals or Relay contacts.

CHARM Keying Posts

The Terminal Blocks contain keying posts that are *automatically* set and locked to the unique position of the installed CHARM. The keys prevent the insertion of an incorrect CHARM during maintenance activities. They are shipped in a neutral position and are set when a CHARM is inserted. If needed, the keys can be manually reset to allow a channel to be re-tasked for a different signal type.

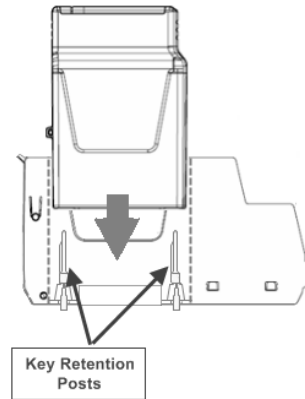

CHARM standard Terminal block

The keying mechanism consists of two keying posts that rotate and lock into the terminal block base. Each CHARM type is assigned a unique key setting.

Hardware Specifications

Common Environmental Specifications (all components)	
Operating temperature	-40 to 70 °C (-40 to 158 °F)*
Storage temperature	-40 to 85 °C (-40 to 185 °F)
Relative humidity	5 to 95% , non-condensing
Protection rating	IP 20, NEMA 12
Airborne contaminants	ISA-S71.04-1985 Airborne Contaminants Class G3 Conformal coating
Shock	10 g ½-sine wave for 11 ms
Vibration	1 mm peak-to-peak from 5 to 13.2 Hz; 0.7 g from 13.2 to 150 Hz

* When used with copper Ethernet I/O Ports (Copper IOP). When used with the Fiber Optic I/O Ports (Fiber Optic IOP), the operating temperature range is limited to -40 to 60 °C (-40 to 140 °F).

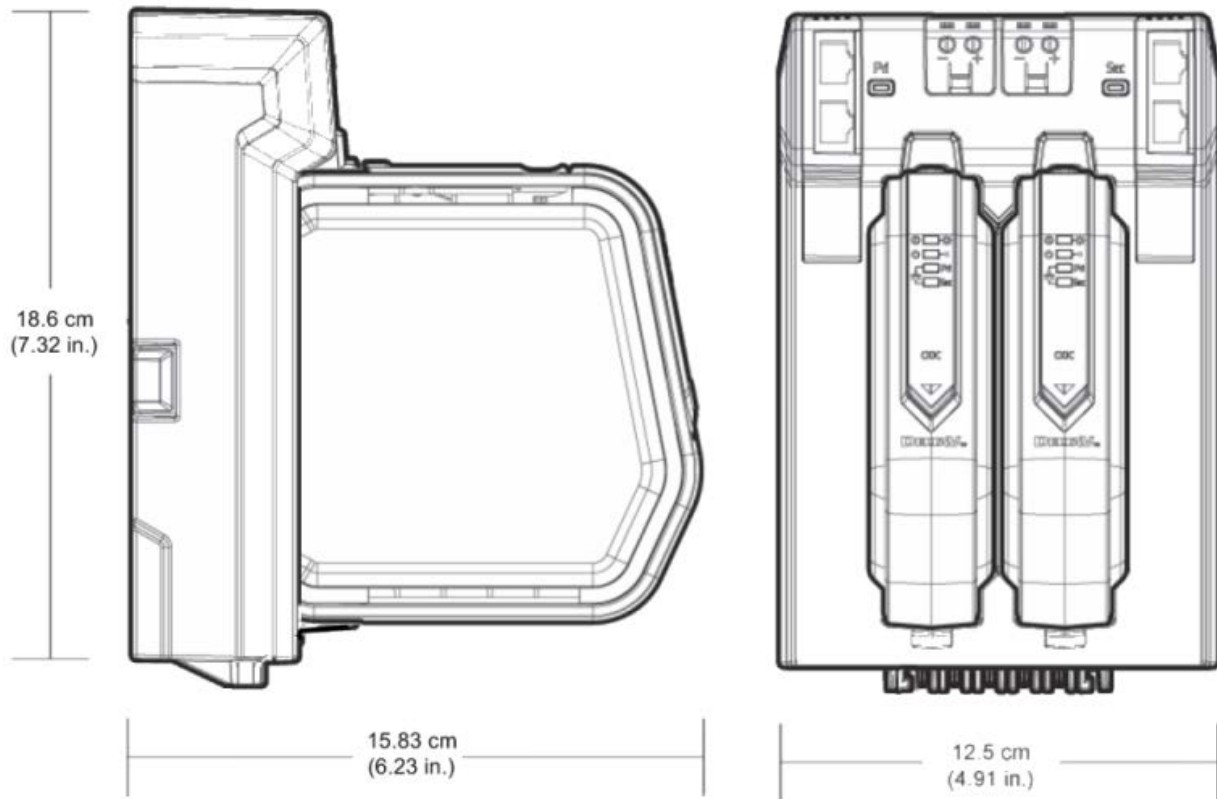

CHARM I/O Card and Carrier

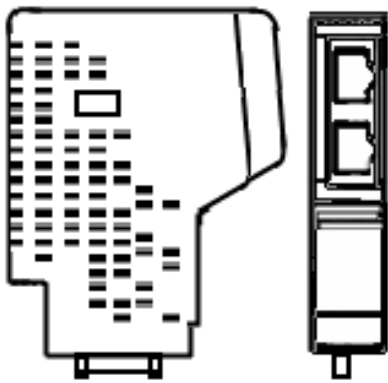

Copper IOP

Uplink Port
Cascade Port

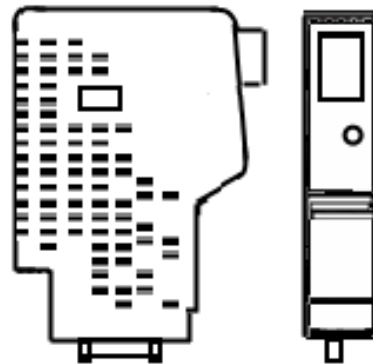

Fiber Optic IOP

Uplink Port

Operating Temperature -40 to 70 °C (-40 to 158 °F)

Operating Temperature -40 to 60 °C (-40 to 140 °F)

CIOC Carrier Ethernet Communication Modules

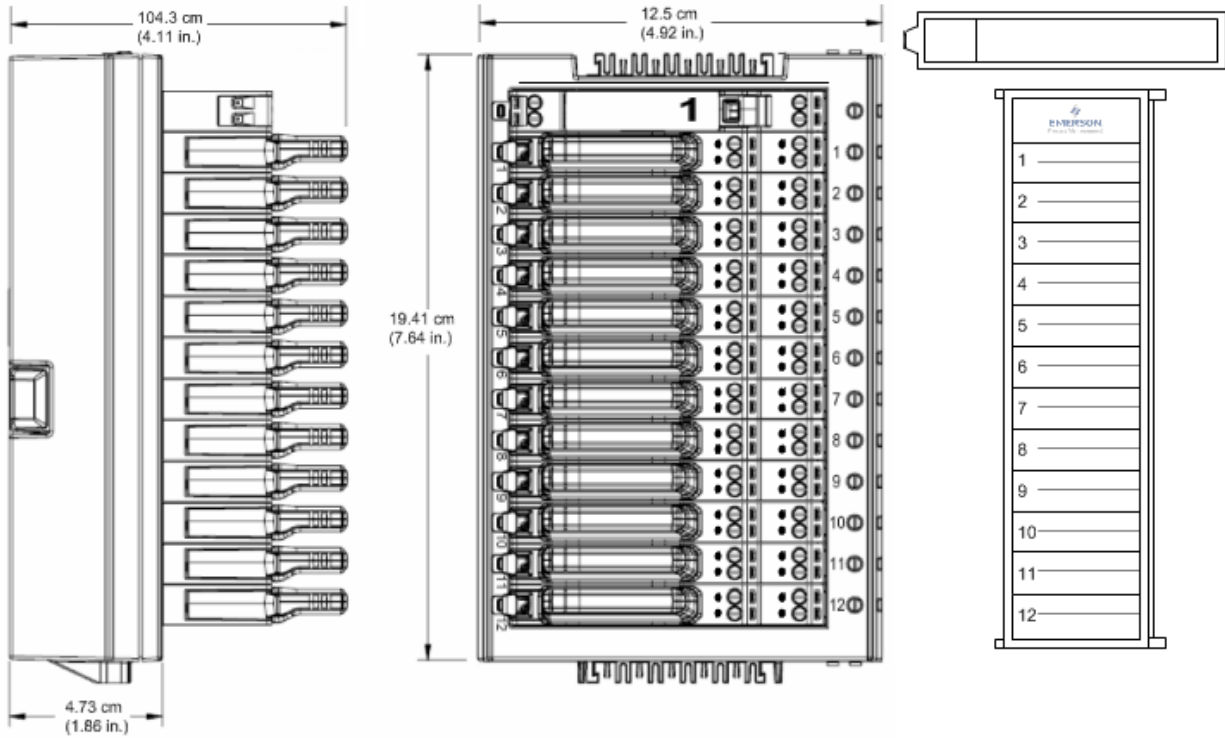

CHARM Baseplate with Identifier, CHARMS and Label Plates

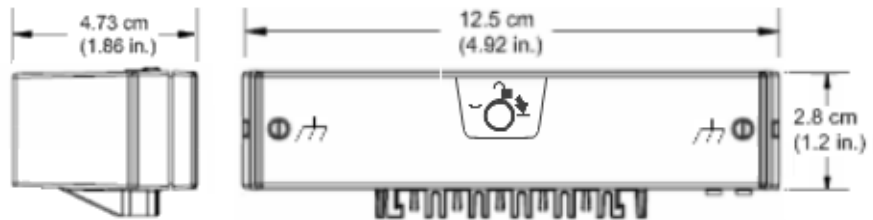

CHARM Baseplate Terminator, Top

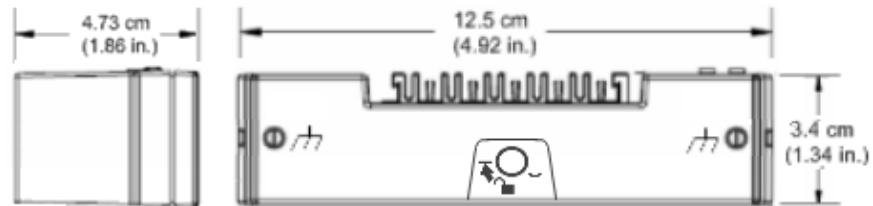

CHARM Baseplate Terminator, Bottom

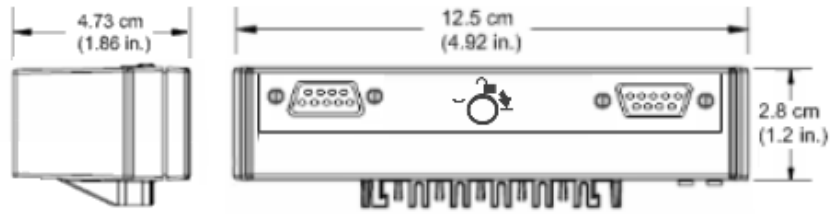

CHARM Baseplate Extender, Top

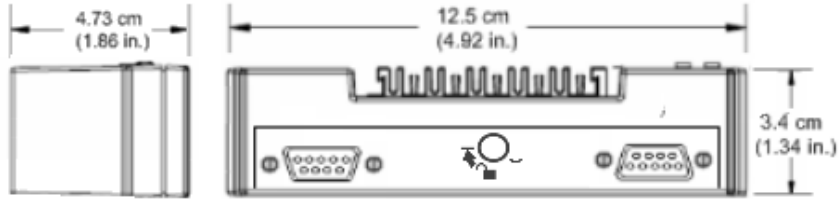

CHARM Baseplate Extender, Bottom

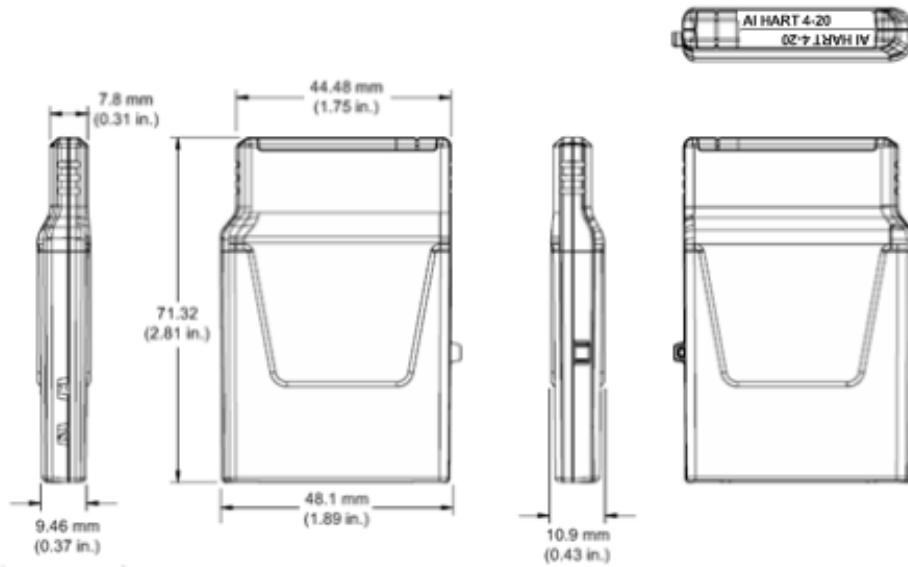

CHARM

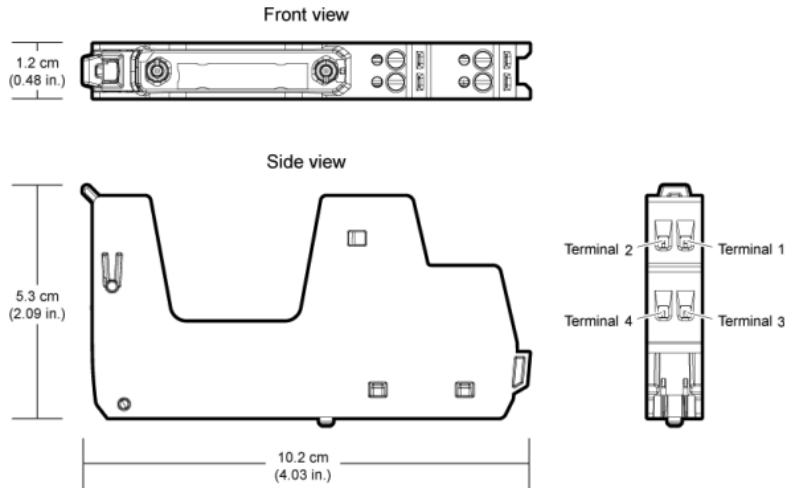

CHARM Standard Terminal Block

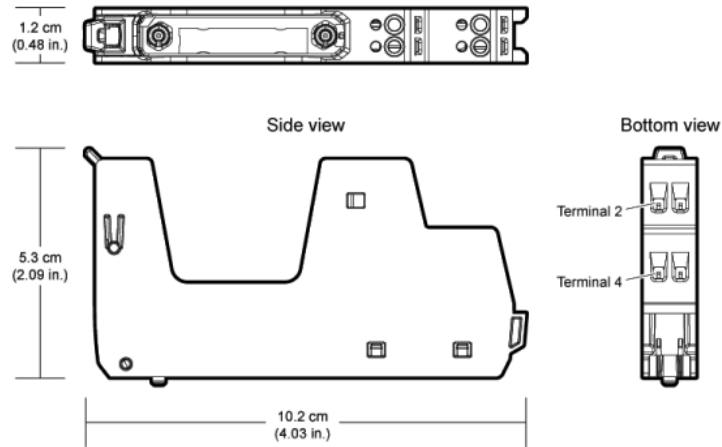

CHARM Injected Power Terminal Block

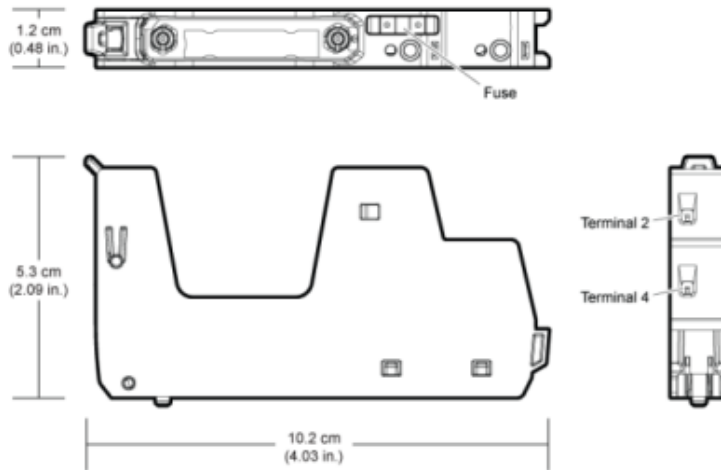

CHARM Fused Injected Power Terminal Block

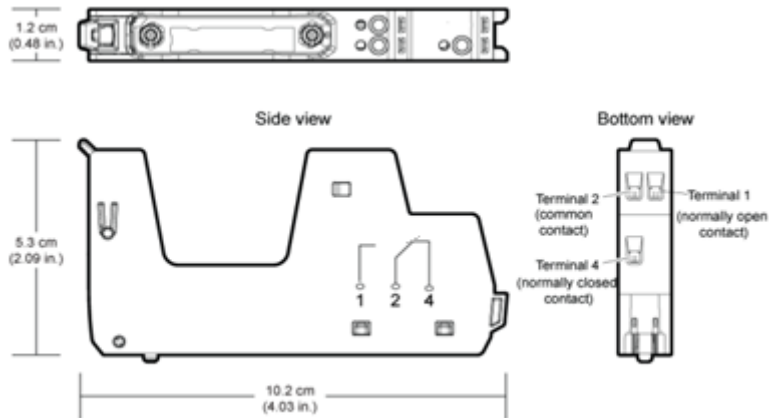

CHARM Relay Output Terminal Block

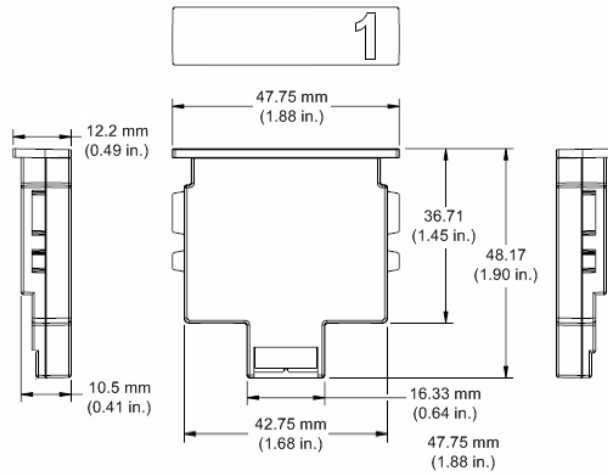

Address Plug

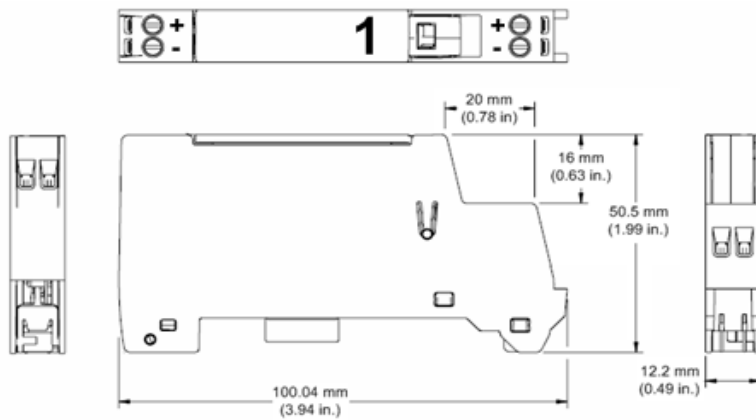

Address Plug Terminal Block

CHARM I/O Card hardware

Specifications for CHARM I/O Card Carrier	
Number of I/O Cards per carrier	2 (redundant pair)
Input power (redundant)	+24 VDC \pm 10% at 12 A maximum
Redundant Ethernet connections via replaceable IOP's	Fiber-optic: 100BASE-FX with MTRJ connectors; <ul style="list-style-type: none"> - Full duplex operation; - Multimode - 2 km nominal distance. Copper twisted pair: 10/100BASE-TX with RJ45 connectors; <ul style="list-style-type: none"> - Full duplex operation - 100 m distance
Mounting	DIN rail Latch to T-type rail
Specifications for CHARM I/O Card	
Number of I/O Channels	96 Channels, Individually defined signal types
Number of I/O Clients	4 (Controllers)
Number of CIOC's per Controller	16
Number of CIOC's per system	300
I/O update rates	50ms, 100ms, 250ms, 500ms
User memory	N/A
CIOC power (24 VDC)	0.28 Amps per Redundant CIOC node (includes two cards and two communication modules) (individual CHARM power requirements are in addition)
CIOC Heat Dissipation	6.68 Watts per Redundant CIOC node <ul style="list-style-type: none"> - 2.0 Watts per CIOC - 1.34 Watts per Copper Ethernet I/O Communication Port - 2.0 Watts per Fiber Optic I/O Communication Port
CIOC output to CHARMS	6.3 VDC redundant power, at 3.25 A maximum*
Fuse Protection (internal)	Internal Non-replaceable Fuse
Mounting	2-wide CHARM I/O Carrier
Communication	Redundant Ethernet connections via CHARM I/O Carrier
Network Addressing	Auto Assigned during commissioning
LED Indicators:	
Green – Power	Indicates DC power is applied.
Red – Error	Indicates an error condition.
Green – Active/Standby	Indicates operating mode of each CIOC
Yellow flashing – Pri./Sec. CN	Indicates valid control network communication.

* Actual CIOC Output to CHARMS is dependent on number of installed CHARMS

CHARM Baseplate	
Number of channels per baseplate	12
Number of base plates per CIOC	8
Addressing	One Address Plug (1 through 8)
Terminal blocks	<ul style="list-style-type: none"> - Standard Terminal Block - Injected Power Terminal Block - Fused Injected Power Terminal Block - Relay Output Terminal Block
Shield connections	1 Screw Cage terminal per channel, plus 1 for cable shield 2.1 -0.32 mm ² / 14 – 22 AWG Gold plated connectors for shield continuity
Wire strip length	7 - 9 mm / 0.28 – 0.36 in.
Mounting	DIN rail Latch to T-type rail
Specifications for Baseplate Termination, Top and Bottom	
Shield Drain wire connections	2 Screw Cage Terminals 2.1 -0.32 mm ² / 14 – 22 AWG
Wire strip length	7 - 9 mm / 0.28 – 0.36 in.
Specifications for Baseplate Extenders, Top and Bottom	
Primary Bus connection	9-pin D-shell, Primary RS-485 communications bus Primary 24 VDC field power Primary CHARM power
Secondary Bus connection	9-pin D-shell, Secondary RS-485 communications bus Secondary 24 VDC field power Secondary CHARM power
Specifications for Extender Cables	
Maximum bus length (including Baseplates)	10 m (32.8 ft)
Available Cable lengths	2 m, 1 m, 0.5 m (6.7 ft, 3.3 ft, 1.6 ft)

Specifications for Standard Terminal Block	
Number of connections	4 Screw Cage terminals 2.1 -0.32 mm ² / 14 – 22 AWG
Strip length	7 - 9 mm / 0.28 – 0.36 in.
Maximum Current	2 A max. at 250 VAC max. *
Color	Black
Specifications for Injected Power Terminal Block	
Number of connections	2 Screw Cage terminals 2.1 -0.32 mm ² / 14 – 22 AWG
Strip length	7 - 9 mm / 0.28 – 0.36 in.
Maximum Current	2 A max. at 250 VAC max. *
Color	Black
Specifications for Fused Injected Power Terminal Block	
Number of connections	2 Screw Cage terminals 2.1 -0.32 mm ² / 14 – 22 AWG
Strip length	7 - 9 mm / 0.28 – 0.36 in.
Maximum Current	1 A max. at 250 VAC max. *
Field replaceable fuse	2 A
Color	Black
Specifications for Relay Output Terminal Block	
Number of connections	3 Screw Cage terminals 2.1 -0.32 mm ² / 14 – 22 AWG
Strip length	7 - 9 mm / 0.28 – 0.36 in.
Maximum Current	5 A at 28.8 VDC / 0.4 A at 48 VDC / 5 A at 250 VAC
Color	Black
Specifications for Address Plug Terminal Block	
Number of connections	2 sets of 2 connections Screw Cage terminals 2.1 -0.32 mm ² / 14 – 22 AWG
Strip length	7 - 9 mm / 0.28 – 0.36 in.
Maximum Current	10 A max. at 250 VAC max. **
Color	Black

* Actual Current draw is determined by type of CHARM and associated field devices.

** Maximum current draw of baseplate is the sum of CHARMS installed with Injected Power Terminal block

Analog Input CHARM

Specifications for AI 4-20 mA HART CHARM	
Sensor Types	4-20 mA with or without HART 0-20 mA Supports 2-wire and 4-wire device types
Nominal signal range (span)	4-20 mA, (0-20 mA optional)
Full signal range	0 to 24 mA
Input Impedance	250 Ω ±1%
Field Power (2-wire)	15.0 V at 20 mA @ 24 VDC input
Accuracy over temperature range	0.1% of span (0-60° C) 0.25% of span (over -40 -70° C)
Repeatability	0.05% of span
Resolution	16 bit A/D converter
Calibration	None required
DC/50/60 Hz Common mode rejection	N/A
Field Circuit Protection	- 30 mA Current Limiting circuit - Field wiring disconnect
CHARM power req.	36 mA max @ 24 VDC for two wire configuration 12 mA max @ 24 VDC for four wire configuration
CHARM Heat Dissipation	0.33 W
HART support	HART v7 pass-through for AMS HART v7 variable and device status available to control
HART data update rates	500 ms

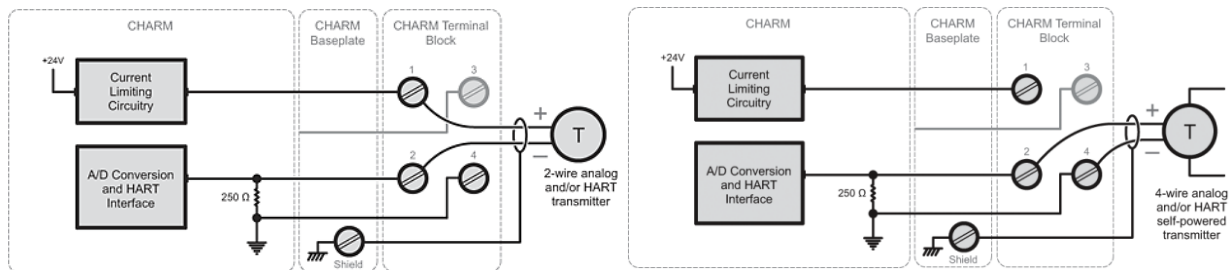

Simplified Circuit and Connection Diagrams for HART AI CHARM 0/4 to 20 mA Two Wire and Four Wire transmitters

RTD CHARM

Specifications for RTD Input CHARM	
Sensor types	RTD input (Types listed in Table)
Sensor Configuration	2 wire, 3 wire, or 4 wire
Full Scale signal range	See Table next page
Accuracy	See Table next page
Repeatability	0.05% of span
Resolution	24 Bit A/D converter / Depends upon the sensor type
Calibration	None required
Sensor excitation current	0.5 mA in 2-wire and 4 wire configurations 0.25 mA in 3-wire
DC/50/60 Hz Common mode rejection	90dB typical
Isolation	Each sensor galvanically isolated and factory tested to 1000 VDC
Open sensor detection	Yes
CHARM power req.	22 mA max @ 24 VDC
CHARM Heat Dissipation	0.30 W

RTD, ohms Sensor Type Specifications				
Sensor Type	Operating Range	25° Reference Accuracy	Temperature Drift	Resolution
Pt100	-200 to 850°C	± 0.25° C	± 0.02° C/°C	~0.02° C
Pt200	-200 to 850°C	± 0.25° C	± 0.02° C/°C	~0.02° C
Pt500	-200 to 850°C	± 0.25° C	± 0.02° C/°C	~0.02° C
Pt1000	-200 to 260°C	± 0.25° C	± 0.02° C/°C	~0.01° C
Ni120	-80 to 260°C	± 0.15° C	± 0.01° C/°C	~0.01° C
Ni100	-80 to 260°C	± 0.20° C	± 0.01° C/°C	~0.01° C
Ni200	-80 to 260°C	± 0.20° C	± 0.01° C/°C	~0.01° C
Ni500	-80 to 260°C	± 0.20° C	± 0.01° C/°C	~0.01° C
Ni1000	-80 to 150°C	± 0.20° C	± 0.01° C/°C	~0.01° C
Cu10	-200 to 260°C	± 0.25° C	± 0.02° C/°C	~0.01° C
Resistance/User Defined*	0 to 2,000 Ω	± 0.25 Ω	± 0.03 Ω/°C	~0.031 Ω

* Callendar-Van Dusen calibration algorithm available for User Defined Pt RTD's. Refer to product documentation

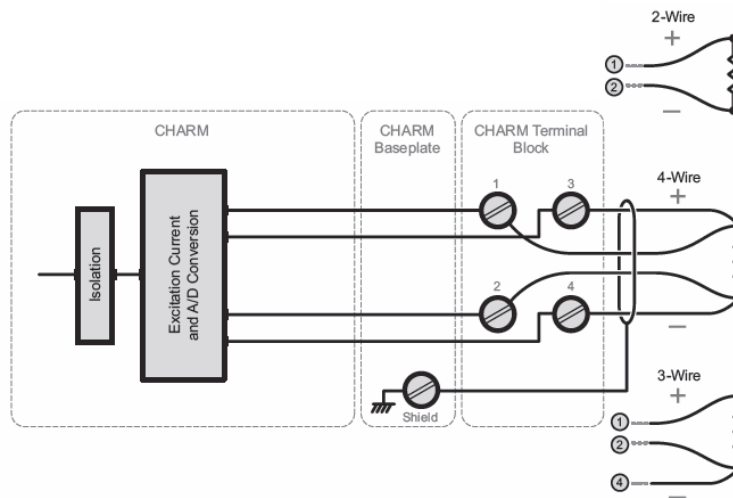

Simplified Circuit and Connection Diagrams for RTD CHARM

Thermocouple/mV CHARM

Specifications for Thermocouple/mV Input CHARM	
Sensor types <ul style="list-style-type: none"> • Thermocouple • mV 	B, E, J, K, N, R, S, T, uncharacterized Low level voltage source
Full Scale signal range	See Table next page
Accuracy	See Table next page
Repeatability	0.05% of span
Resolution	24 Bit A/D converter / Depends upon the sensor type
Calibration	None required
Cold junction compensation(CJC) <ul style="list-style-type: none"> Accuracy Range 	± 1.0° C -40 to 85° C
DC/50/60 Hz Common mode rejection	90dB
Isolation	Each sensor galvanically isolated and factory tested to 1000 VDC
Open sensor detection	Yes
CHARM power req.	22 mA max @ 24 VDC
CHARM Heat Dissipation	0.30 W

Sensor Type Specifications					
Sensor Type	25° Reference Accuracy ¹	Temperature Drift	Nominal Resolution	Full Scale	Operating Range
B	± 0.8° C	± 0.06 ° C/ °C	~ 0.024° C	0 to 1820° C	250 to 1820° C
E	± 0.4° C	± 0.03° C/ °C	~ 0.018° C	-270 to 1000° C	-200 to 1000° C
J	± 0.6° C	± 0.04° C/ °C	~ 0.022° C	-210 to 1200° C	-210 to 1200° C
K	± 0.4° C	± 0.03° C/ °C	~ 0.025° C	-270 to 1372° C	-200 to 1372° C
N	± 0.6° C	± 0.04° C/ °C	~ 0.024° C	-270 to 1300° C	-200 to 1300° C
R	± 0.8° C	± 0.05° C/ °C	~ 0.028° C	-50 to 1768° C	-50 to 1768° C
S	± 0.8° C	± 0.05° C/ °C	~ 0.028° C	-50 to 1768° C	-50 to 1768° C
T	± 0.5° C	± 0.02° C/ °C	~ 0.01° C	-270 to 400° C	-250 to 400° C
± 100 mV	0.025 mV	± 0.002 mV/ °C	~ 0.0031mV	-100 to 100 mV	-100 to 100 mV
± 50 mV	0.020 mV	± 0.001 mV/ °C	~ 0.0015mV	-50 to 50 mV	-50 to 50 mV
± 20 mV	0.010 mV	± 0.0005 mV/ °C	~ 0.0006mV	-20 to 20 mV	-20 to 20 mV

¹Total error is made up of the 25 C reference accuracy value, plus the CJC accuracy value, plus the sensor accuracy value

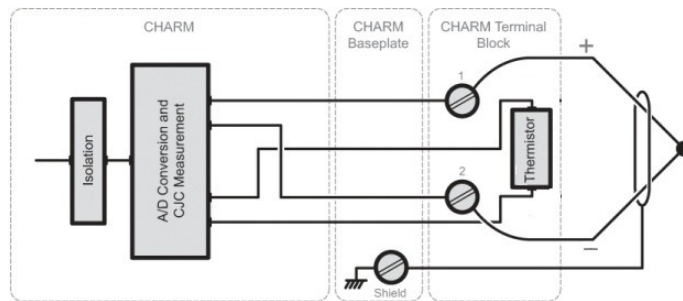

Simplified Circuit and Connection Diagram for Thermocouple/mV CHARM

Voltage Charm

Specifications for AI 0-10 VDC Isolated CHARM	
Sensor types	Voltage device
Full Scale signal range	See Table next page
Accuracy	See Table next page
Input Impedance	10 MΩ
Repeatability	0.05% of span
Resolution	24 bit A/D converter / Refer to the following table
Calibration	None required
Common mode rejection	90dB at 50/60 Hz
Isolation	Input channel galvanically isolated and factory tested to 1000 VDC
CHARM power req.	22 mA max @ 24 VDC
CHARM Heat Dissipation	0.40 W

Isolated Input Voltage Sensor Type Specifications				
Sensor Type	Sensor Range	25° Reference Accuracy ¹	Temperature Drift	Nominal Resolution
0 to 5 V	0 to 5 V	±0.005 V	±0.0005 V/°C	0.00008 V
0 to 10 V	0 to 10 V	±0.010 V	±0.001 V/°C	0.00015 V
1 to 5 V	1 to 5 V	±0.005 V	±0.0005 V/°C	0.00006 V
1 V	-1 to +1 V	±0.0025 V	±0.0002 V/°C	0.00003 V
5 V	-5 to +5 V	±0.005 V	±0.0005 V/°C	0.00015 V
10 V	-10 to +10 V	±0.010 V	±0.001 V/°C	0.00030 V

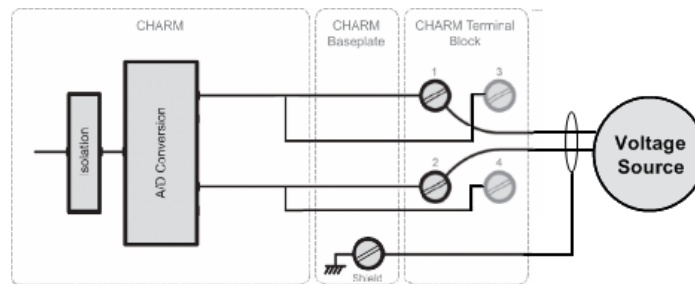

Simplified Circuit and Connection Diagram for Isolated Voltage CHARM

Note: Installing a 250 Ω range resistor across terminals 3 and 4 converts a 4-20 mA field signal to 1-5V input signal

Analog Output CHARM

Specifications for AO 4-20 mA HART CHARM	
Sensor Types	4 to 20 mA with or without HART 0 to 20 mA
Nominal signal range (span)	4 to 20 mA, (0 to 20 mA option)
Full signal range	0 to 24 mA
Accuracy over temperature range	0.25% of span (0 to 60 °C) 0.5% of span (-40 to 70 °C)
Resolution	16 bit D/A converter
Calibration	None required
Available field power	20 mA at 15 VDC supply into 750 Ω load
Open-Loop Detection	< 0.70 mA (on 4 to 20 mA signal)
Field Circuit Protection	- 24 mA Current Limiting Circuit - Field wiring disconnect
CHARM power req.	42 mA max @ 24 VDC
CHARM Heat Dissipation	0.48 W
HART support	HART v7 pass-through for AMS HART v7 variable and device status available to control
HART data update rates	500 ms

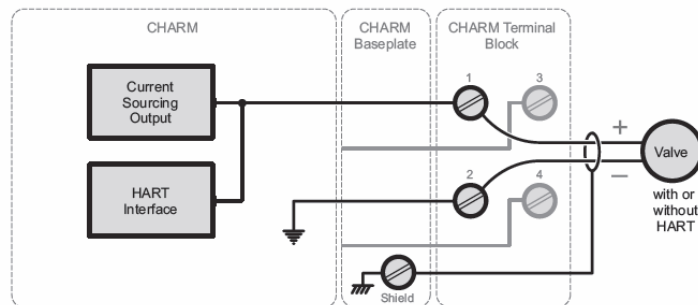

Simplified Circuit and Connection Diagram for HART AO CHARM 0/ 4 to 20 mA

Discrete Input CHARMS

Specifications for DI NAMUR CHARM	
Sensor Types	NAMUR Sensors, Dry Contacts
Detection level for On	> 2.1 mA (<4 kΩ)
Detection level for Off	< 1.2 mA (>9 kΩ)
Channel Impedance	1.5 KΩ (approximate)
Wetting Voltage	12 Volts (± 5%)
Fault Detection capable	NAMUR Sensors or field resistor pack <ul style="list-style-type: none"> Guaranteed short circuit: <100 Ω Guaranteed good status: 400 Ω to 40 kΩ Guaranteed open circuit: > 75 kΩ
Configurable channel types: <ul style="list-style-type: none"> Discrete input Pulse Count 	Dry contact or discrete state sensor changing <2 Hz Pulse train 0.1 Hz to 10 KHz, 50 μsec min pulse width
Field Circuit Protection	- 8 mA Current Limiting Circuit - Field wiring disconnect
CHARM power req.	28 mA max @ 24 VDC
CHARM Heat Dissipation	0.51 W

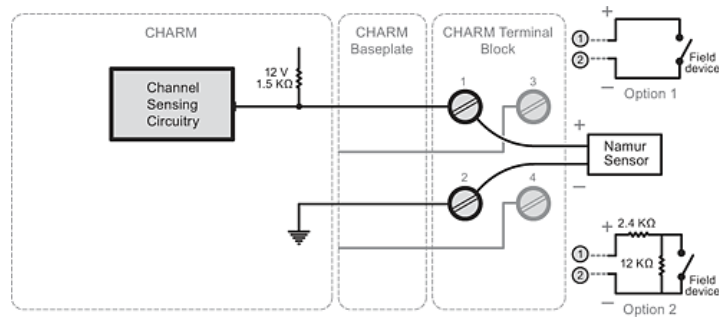

Simplified Circuit and Connection Diagram for DI NAMUR CHARM

Specifications for DI 24 VDC low-side sense (dry contact) CHARM	
Sensor Types	24 VDC Dry Contacts
Detection level for On	> 2.25 mA (<5.3 kΩ)
Detection level for Off	< 1.75 mA (>8.2 kΩ)
Channel Impedance	4.8 KΩ (approximate)
Wetting Voltage	22.5Volts (± 5%), current limited to 12.5 mA nominal
Fault Detection capable	field resistor pack (optional) <ul style="list-style-type: none"> • Guaranteed short circuit: <100 Ω • Guaranteed good status: 400 Ω to 40 kΩ • Guaranteed open circuit: > 75 kΩ
Configurable channel types: <ul style="list-style-type: none"> • Discrete input • Pulse Count 	Dry contact or discrete state sensor changing <2 Hz Pulse train 0.1 Hz to 10 KHz, 50 μsec min pulse width
Field Circuit Protection	- 12.5 mA Current Limiting Circuit - Field wiring disconnect
CHARM power req.	22 mA max @ 24 VDC
CHARM Heat Dissipation	0.33 W

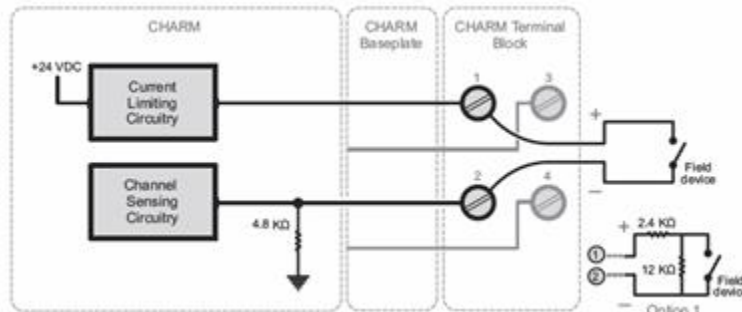

Simplified Circuit and Connection Diagram for DI 24 VDC low-side sense CHARM

Specifications for DI 24 VDC Isolated CHARM	
Detection level for On	> 10 VDC
Detection level for Off	< 5 VDC
Wetting Current	6 mA @ 24 VDC
Input Impedance	4 K Ω (approximately)
Isolation	Galvanically isolated and factory tested to 1000 VDC
Configurable channel types: Discrete input Pulse Count	Dry contact or discrete state sensor changing <2 Hz Pulse train 0.1 Hz to 10 KHz, 50 μ sec min pulse width
Field Circuit Protection	- 6 mA Current Limiting Circuit Recommend External Fuse at power source
CHARM power req.	12 mA max @ 24 VDC
CHARM Heat Dissipation	0.32 W

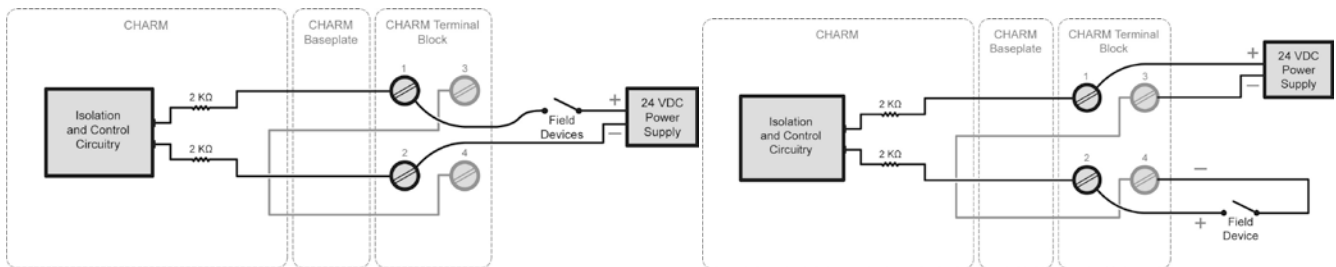

Simplified Circuit and Connection Diagrams for DI 24 VDC Isolated CHARM

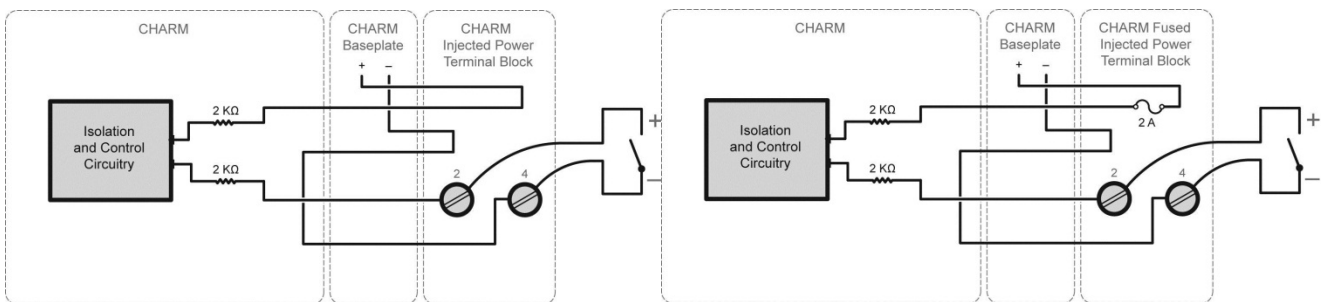

Simplified Circuit and Connection Diagrams for DI 24 VDC Isolated CHARM with Non-fused and fused Injected Power Terminal Block

Specifications for DI 120 VAC Isolated CHARM	
Detection level for On	> 84 VAC
Detection level for Off	< 34 VAC
Wetting Current	2 mA at 120 VAC
Leakage Current	Max. 400 microAmps
Input Impedance	60 K Ω (approximately)
Isolation	Each channel is optically isolated from the system at 250 VAC
Maximum Input Voltage	130 VAC
Frequency	50/60 Hz
Field Circuit Protection	<ul style="list-style-type: none"> - 2 mA Current Limiting Circuit - Recommend External Fuse at power source - Field wiring disconnect
CHARM power req.	12 mA max @ 24 VDC
CHARM Heat Dissipation	0.41 W

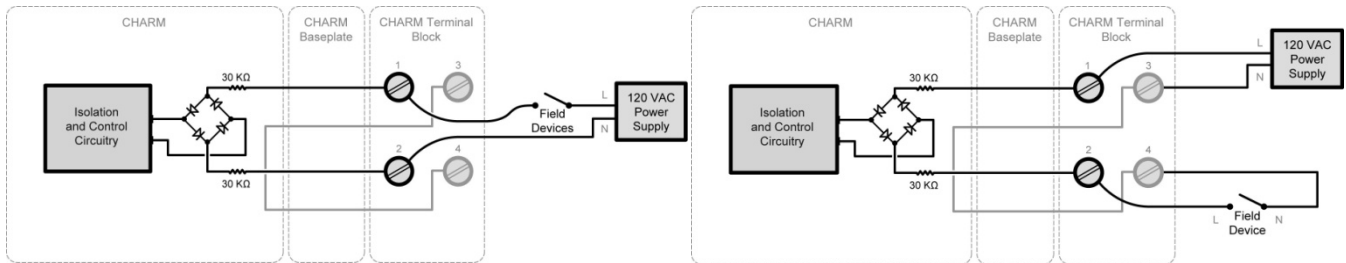

Simplified Circuit and Connection Diagrams for DI 120 VAC Isolated CHARM

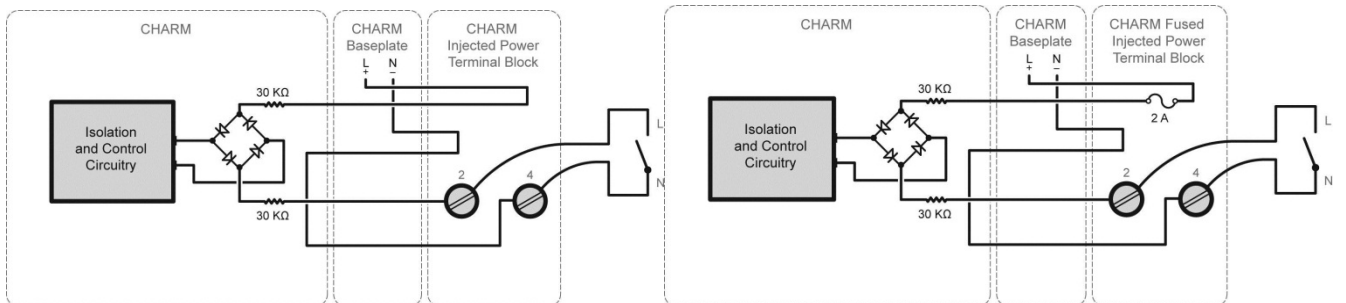

Simplified Circuit and Connection Diagrams for DI 120 VAC Isolated CHARM with Non-fused and fused Injected Power Terminal Block

Specifications for DI 230 VAC Isolated CHARM	
Detection level for On	> 168 VAC
Detection level for Off	< 68 VAC
Wetting Current	1 mA at 230 VAC
Input Impedance	240 KΩ (approximately)
Isolation	Each channel is optically isolated from the system at 250 VAC and from other channels at 250 VAC.
Maximum Input Voltage	250 VAC
Frequency	50/60 Hz
Field Circuit Protection	<ul style="list-style-type: none"> - 1 mA Current Limiting Circuit - Recommend External Fuse at power source - Field wiring disconnect
CHARM power req.	12 mA max @ 24 VDC
CHARM Heat Dissipation	0.40 W

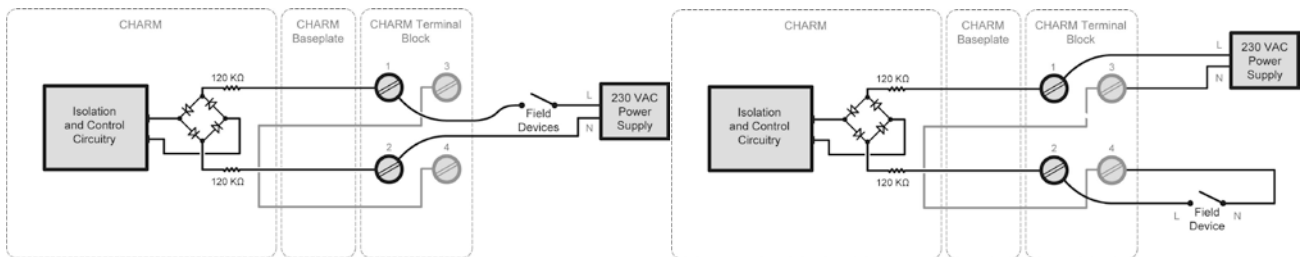

Simplified Circuit and Connection Diagrams for DI 230 VAC Isolated CHARM

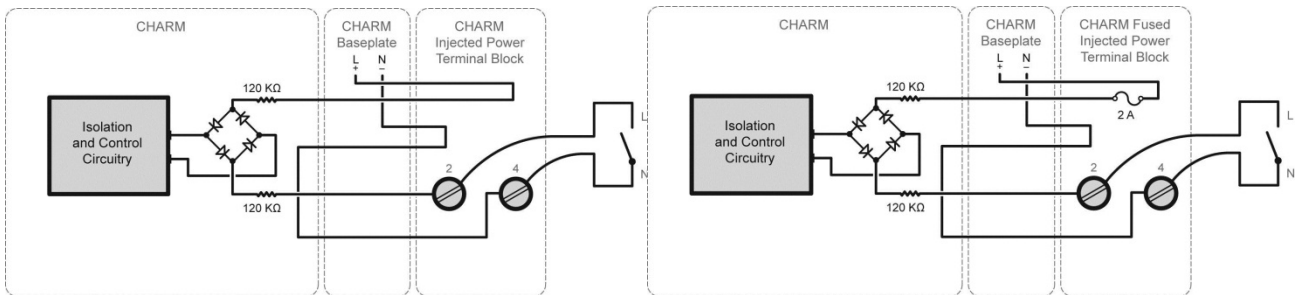

Simplified Circuit and Connection Diagrams for DI 230 VAC Isolated CHARM

with Non-fused and fused Injected Power Terminal Block

Discrete Output CHARMS

Specifications for DO 24 VDC High-Side CHARM	
Device Type	24 VDC Solenoid coils
On State Output rating	100 mA continuous @ 24 VDC
Off-state leakage	1 mA maximum
Line Fault Detection	<ul style="list-style-type: none"> Guaranteed short circuit: <math>< 50 \Omega</math> load Guaranteed good status: 240 Ω to 10 kΩ load Guaranteed open circuit: >20 kΩ load
Line Fault Test timing	200 μ sec
Configurable output behavior	Latching Output Momentary Output Continuous Pulse Output
Field Circuit Protection	- 200 mA Current Limiting Circuit with PTC - Field wiring disconnect
CHARM power req.	116 mA max @ 24 VDC
CHARM Heat Dissipation	0.44 W

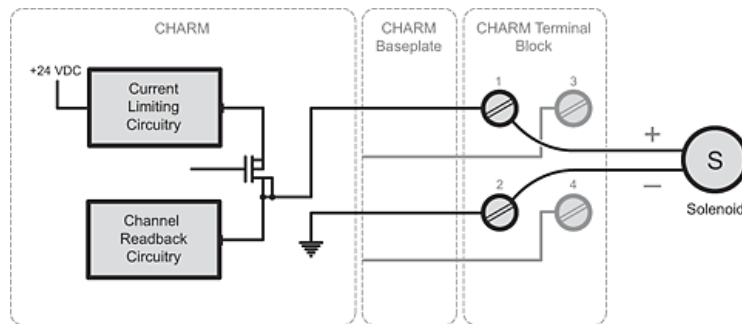

Simplified Circuit and Connection Diagram for DO 24 VDC High Side CHARM

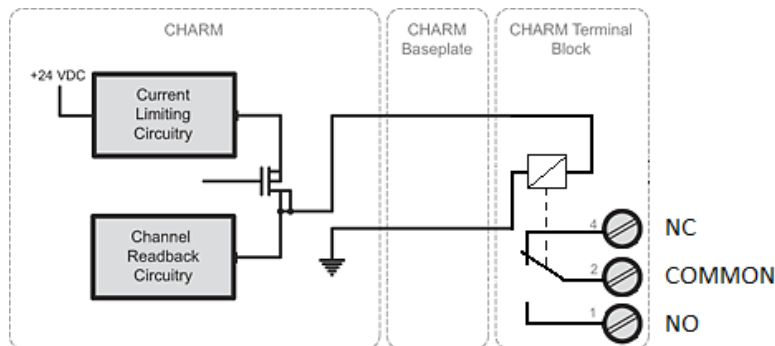

Simplified Circuit and Connection Diagram for DO 24 VDC High Side CHARM with CHARM Relay Output Terminal Block

Specifications for DO 100 mA Energy Limited CHARM	
Device Type	24 VDC Solenoid coils
On State Output rating	100 mA continuous @ 24 VDC
Off-state leakage	1 mA maximum
Line Fault Detection	<ul style="list-style-type: none"> Guaranteed short circuit: <math>< 50 \Omega</math> load Guaranteed good status: 240 Ω to 10 kΩ load Guaranteed open circuit: >20 kΩ load
Line Fault Test timing	200 μ sec
Configurable output behavior	Latching Output Momentary Output Continuous Pulse Output
Field Circuit Protection	- 107 mA Current Limiting Circuit - Field wiring disconnect
CHARM power req.	116 mA max @ 24 VDC
CHARM Heat Dissipation	0.56 W

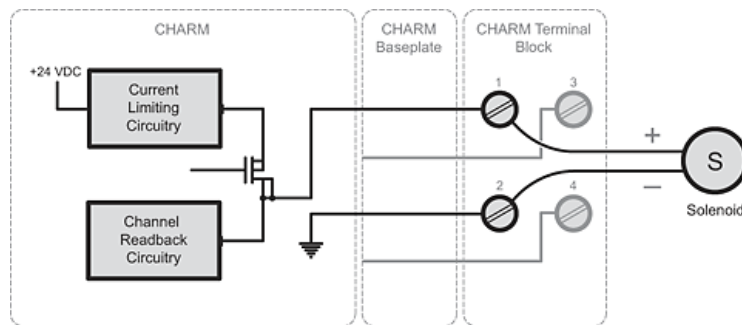

Simplified Circuit and Connection Diagram for DO 100 mA Energy limited CHARM

Specifications for DO 24 VDC Isolated CHARM	
Device Type	24 VDC Inductive Load
Output range	4 VDC to 32 VDC
Output rating	1.0 A continuous (2 A inrush for < 100 msec)
Off state leakage	1 mA maximum
Configurable output behavior	Momentary Output Continuous Pulse Output
Isolation	The output channel is galvanically isolated and factory tested to 1000 VDC.
Field Circuit Protection	- 4 A Current Limiting Circuit (Short Circuit) with thermal shutoff, automatic reset. Recommend external fuse at power source
CHARM power req.	22 mA max @ 24 VDC
CHARM Heat Dissipation	0.46 W

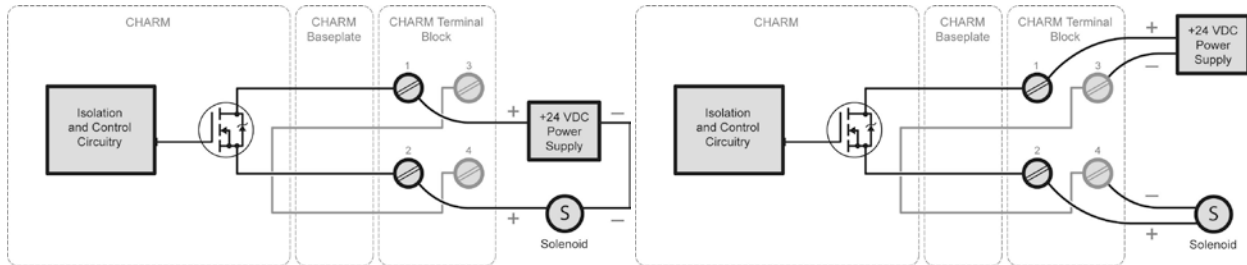

Simplified Circuit and Connection Diagrams for DO 24 VDC Isolated CHARM

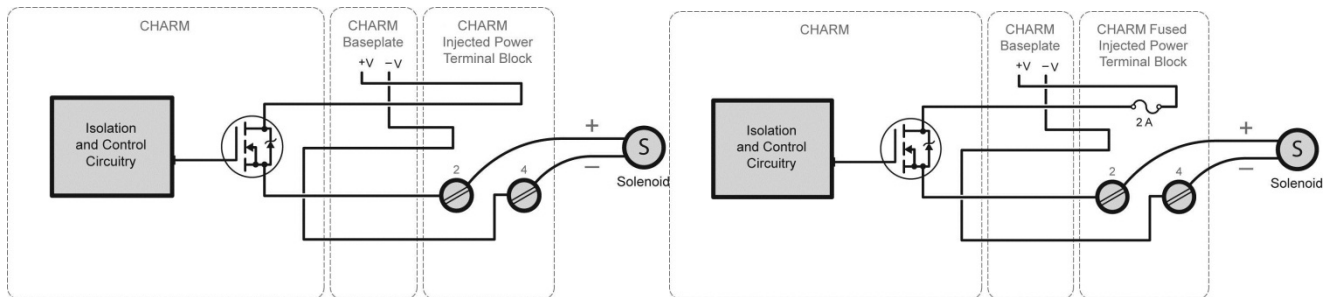

Simplified Circuit and Connection Diagrams for DO 24 VDC Isolated CHARM

with Non-fused and fused Injected Power Terminal Block

Specifications for DO VAC Isolated CHARM	
Sensor types	VAC Inductive load
Off state leakage	2 mA maximum at 120 VAC 4 mA maximum at 230 VAC
Output range	20 to 250 VAC
Output rating	0.5 A maximum continuous per channel
Configurable output behavior	Momentary Output Continuous Pulse Output
Isolation	Each channel is optically isolated from the system at 250 VAC and from other channels at 250 VAC.
Field Circuit Protection	- External Fuse recommended at power source 4 Amps max.
Inrush Current	10 A < 20 ms, 5 A < 100 ms, 0.5 A continuous
CHARM power req.	12 mA max @ 24 VDC
CHARM Heat Dissipation	0.70 W

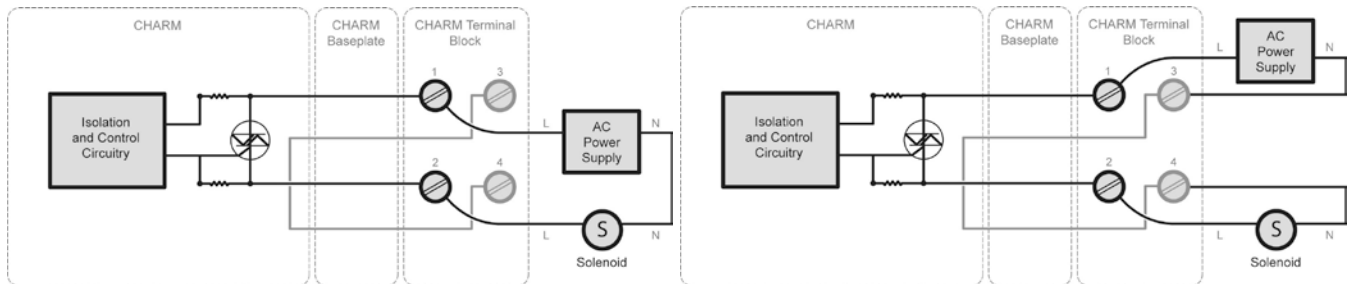

Simplified Circuit and Connection Diagrams for DO VAC Isolated CHARM

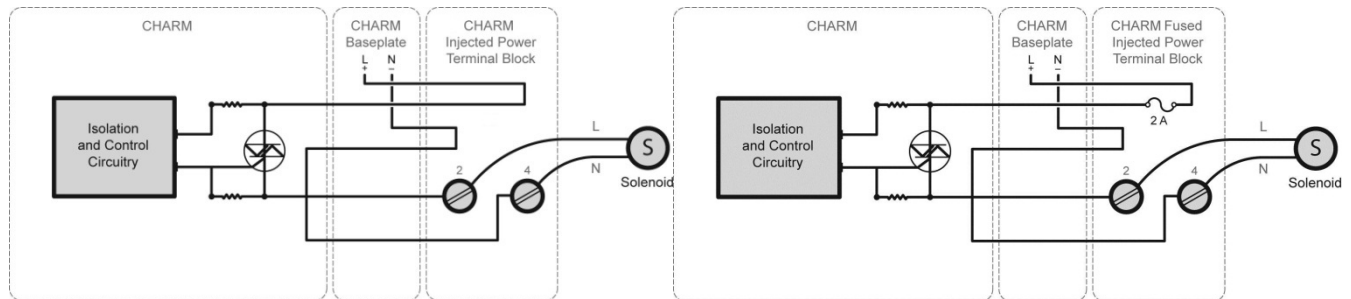

Simplified Circuit and Connection Diagrams for DO VAC Isolated CHARM

with non-fused and fused Injected Power Terminal Block

System Compatibility

CHARM I/O hardware requires:

- SX or SD Plus controllers

S-series Controllers with CHARMs I/O and M-series controllers can be installed on the same DeltaV Area Control Network in v11 and beyond. Control modules can be assigned to either series of controller and inter-controller references are fully supported between controller series.

Certifications

The following certifications are available on CHARMS:

■ CE:

- EMC- EN 61326-1:2006
- LVD: Directive 2006/95/EC Aug 2007

■ FM:

- FM 3600, Nov. 1998
- FM 3611, Dec. 2004
- FM 3810, Jan 2005
- ANSI/ISA 60079-0, Oct 2009
- ANSI/ISA 60079-15, Jul 2009

■ CSA:

- CSA C22.2 No. 213-M1987, 1987
(Reaffirmed 2008)
- CSA C22.2 No. 61010-1, 2004
(Reaffirmed 2009)
CAN/CSA-E60079-0, 2007
- CAN/CSA-E60079-15, March 2002
(Reaffirmed 2006)

■ ATEX:

- ATEX 94/9/EC
- EN60079-0: 2009
- EN60079-15:2005
- EN60079-15:2010

■ IEC-Ex:

- IEC60079-0:2007
- IEC60079-15:2005
- IEC60079-15:2010

■ Marine Certifications:

IACS E10:2006 Rev.5 Control, Protection & Safety

- ABS Certificate of Design Assessment
- Bureau Veritas Certificate
- DNV Marine Certificate
- Lloyds Register

■ GOST Hazardous Area certification Zone 2 (Russian)

- POCC US.ГБ05.B03564

Hazardous Area/Location:

CHARMs can be installed and used based on the following Standards

■ **FM (USA):**

Installation and Field Circuits:

Class I, Division 2, Groups A, B, C, D, T4

■ **cFM (Canada):**

Installation and Field Circuits:

Class I, Division 2, Groups A, B, C, D, T4

■ **ATEX:**

Installation and Field Circuits:



Ex nA IIC T4 Gc



Ex nA nL IIC T4 Gc



Ex nA nC IIC T4 Gc

■ **IEC-Ex:**

Installation and Field Circuits:

Ex nA IIC T4 Gc

Ex nA nL IIC T4 Gc

Ex nA nC IIC T4 Gc

Regarding the Installation instructions please refer to the following Documents:

<i>Class 1 Division 2 Installation Instructions CHARM Subsystem</i>	<i>12P5401 Rev. C</i>
<i>Class 1 Division 2 Installation Instructions DeltaV S-Series</i>	<i>12P5402 Rev. A</i>
<i>Zone 2 Installation Instructions CHARM Subsystem</i>	<i>12P5403 Rev. B</i>
<i>Zone 2 Installation Instructions DeltaV S-Series</i>	<i>12P5404 Rev. A</i>

Ordering Information

CHARM I/O Cards	
Description	Model Number
Redundant CIOC with Copper Ethernet , includes redundant pair of CHARM I/O Cards, CHARM I/O Carrier with Screw Terminals, Copper I/O Ports, a Baseplate Identifier and a Baseplate Separator	SE6501T01
Redundant CIOC with fiber optics Ethernet , includes redundant pair of CHARM I/O Cards, CHARM I/O Carrier with Screw Terminals, Fiber-Optic I/O Ports, a Baseplate Identifier and a Baseplate Separator	SE6501T02*
Redundant CIOC , includes 2 CHARMs I/O Cards, (Order these with standard cabinets)	SE6502
CHARM Baseplates	
Description	Model Number
CHARMs Baseplate Assembly , includes CHARMs Baseplate, CHARM Address Terminal Block with Screw Terminals, 12 Standard CHARM Terminal Blocks and a Baseplate Identifier	SE4601T07
CHARMs Baseplate Assembly with Fused Injected Field Power , includes CHARMS Baseplate, CHARM Address Terminal Block with Screw Terminals, 12 Fused Injected Power CHARM Terminal Blocks and a Baseplate Identifier	SE4601T08
CHARMs Baseplate Assembly with Relay Output , includes CHARMS Baseplate, CHARM Address Terminal Block with Screw Terminals, 12 Relay Output CHARM Terminal Blocks and a Baseplate Identifier	SE4601T05
CHARM I/O Baseplate Address Plugs	
Description	Model Number
CHARMs Addressing Plugs , includes Address Plugs 1 through 8	SE4602
CHARM I/O Baseplate Extender, Terminator & Cables	
Description	Model Number
CHARMs Baseplate Extender with Cable Connectors, Top (Male) includes a Baseplate Identifier and a Baseplate Separator	SE4603T05
CHARMs Baseplate Extender with Cable Connectors, Bottom (Female) includes a Baseplate Identifier and a Baseplate Separator	SE4603T06
CHARMs Baseplate Terminator, Top (Male) includes a Baseplate Identifier and a Baseplate Separator	SE4604T03
CHARMs Baseplate Terminator, Bottom (Female) includes a Baseplate Identifier and a Baseplate Separator	SE4604T04
CHARMs Baseplate Cables , includes two 0.5 m cables	SE4605T02
CHARMs Baseplate Cables , includes two 1 m cables	SE4605T03
CHARMs Baseplate Cables , includes two 2 m cables	SE4605T04

Each vertical DIN rail requires a DIN Rail stop to lock baseplates in position. Order VE4054DRS, which is a box of 5.

Prerequisites

S-Series Electronic Marshalling hardware requires DeltaV v11.3.x or later software.

* Redundant CIOC with fiber optics Ethernet requires DeltaV v11.3.1 or later software

Ordering Information

CHARM I/O Labeling	
Description	Model Number
Channel Identifier Labels for CHARM Baseplates; Package of 8	SE4606T02
Low Voltage Instrumentation CHARMs	
DI NAMUR	SE4301T01
DI 24 VDC low-side sense (dry contact)	SE4301T02
DI 24 VDC Isolated	SE4301T07
DO 24 VDC High-Side	SE4302T01
DO 24 VDC Isolated	SE4302T02
DO 24 VDC 100mA Energy Limited	SE4302T04
AI 4-20 mA HART	SE4303T01
Thermocouple/mV Input	SE4303T02
RTD Input	SE4303T03
AI 0-10 VDC Isolated	SE4303T04*
AO 4-20 mA HART	SE4304T01
High Voltage Instrumentation CHARMs	
DI 120 VAC Isolated	SE4301T03
DI 230 VAC Isolated	SE4301T04
DO VAC Isolated	SE4302T03

Prerequisites

S-Series Electronic Marshalling hardware requires DeltaV v11.3.x or later software.

* AI 0-10 VDC Isolated requires DeltaV v11.3.1 or later software

Spare part ordering Information

SPARE PARTS	
Description	Model Number
Charm Baseplate Identifier (Qty. 1)	KL4502X1-KA1

To locate a sales office near you, visit our website at:
www.EmersonProcess.com/DeltaV
Or call us at:
Asia Pacific: 65.777.8211
Europe, Middle East: 41.41.768.6111
North America, Latin America: +1 800.833.8314 or
+1 512.832.3774

For large power, water, and wastewater applications
contact Power and Water Solutions at:
www.EmersonProcess-powerwater.com
Or call us at:
Asia Pacific: 65.777.8211
Europe, Middle East, Africa: 48.22.630.2443
North America, Latin America: +1 412.963.4000

© Emerson Process Management 2012. All rights reserved. For Emerson Process Management trademarks and service marks, go to:
<http://www.emersonprocess.com/home/news/resources/marks.pdf>.

The contents of this publication are presented for informational purposes only, and while every effort has been made to ensure their accuracy, they are not to be construed as warranties or guarantees, express or implied, regarding the products or services described herein or their use or applicability. All sales are governed by our terms and conditions, which are available on request. We reserve the right to modify or improve the design or specification of such products at any time without notice.



www.DeltaV.com

