

Control Studio On-Line

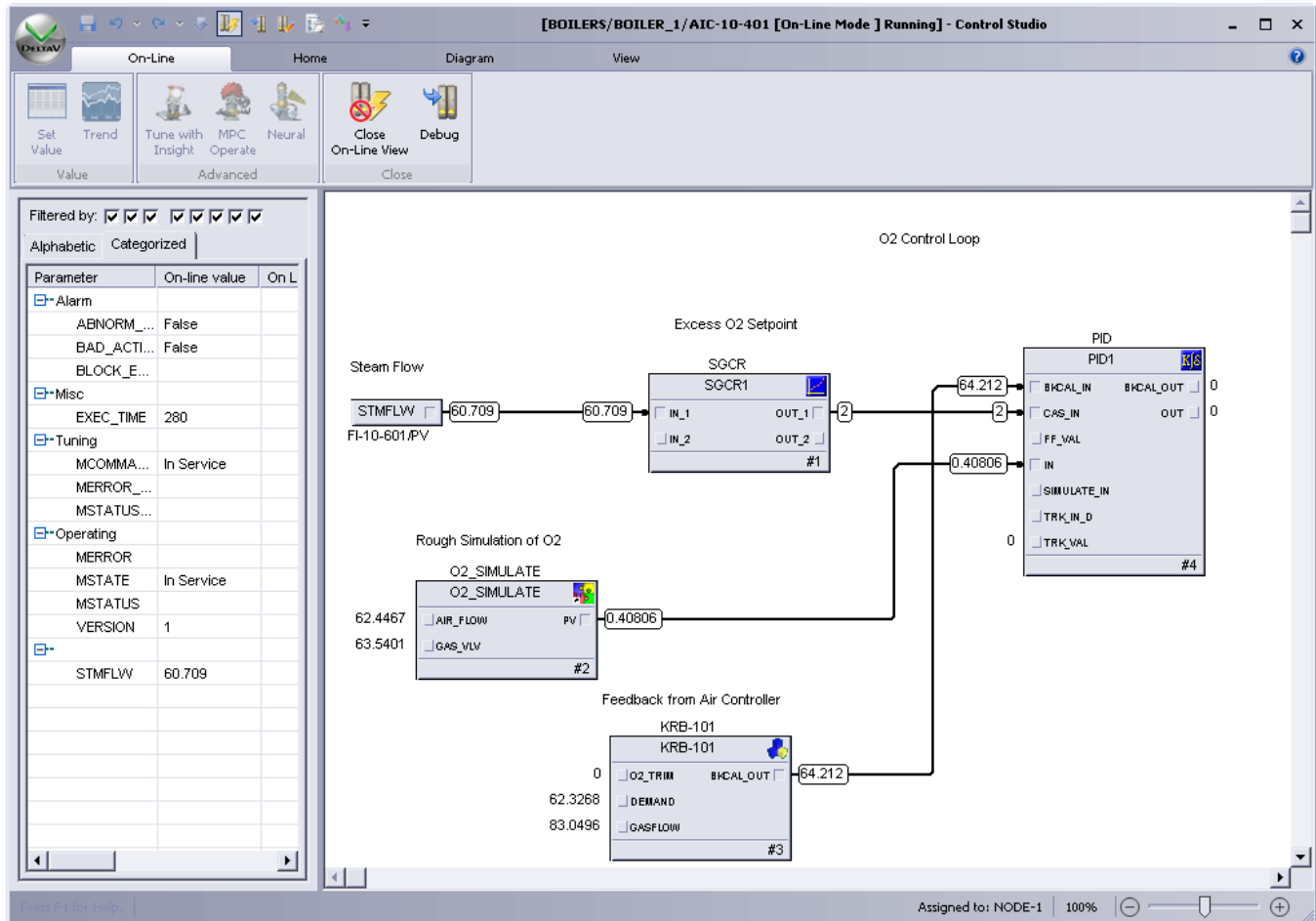

Control strategies can be graphically viewed and tuned as they are executing.

- Graphically displays executing control strategies so you can modify parameters
- Offers operators easy online information
- Equips you with complete troubleshooting capabilities
- Electronic signatures

Introduction

Are you tired of deciphering cryptic control languages or pages of registers to debug your control strategies? Are you using one set of tools to configure your control strategies and a different set of tools for debugging?

With Control Studio On-line, you can view your executing control strategies using the *same graphical view* that you used when you configured your strategies. When online, this view updates with the *actual running values*.



Benefits

Graphically displays executing control strategies so you can modify parameters. After you have installed a module, you can easily view and manipulate to understand its execution. Simply select “on-line” for a module and view its actual execution in the same graphical representation used to edit the module.

Offers operators easy online information. You can understand a loop or motor or even determine why a sequence isn’t progressing using Control Studio On-line. Control Studio On-line can be easily accessed from the DeltaV *Operator Interface*, when both are present on the same workstation. Simply select the Control Studio On-line button from the module faceplate.

Equips you with complete troubleshooting capabilities. You can stop execution, execute a single

block or step at a time, set a break point that stops execution at a particular point, or force specific values to override the actual signal—all without affecting other control modules that may be running in the same controller.

The DeltaV system uses *FOUNDATION fieldbus* function blocks, allowing you to view and modify your executing control strategies in the fieldbus device, the DeltaV system, or a combination of both.

Electronic Signatures. This is an optional feature that can be enabled for individual parameters and fields in selected modules when there is a need to authenticate the person that is requesting an online value change before the change can be accepted.

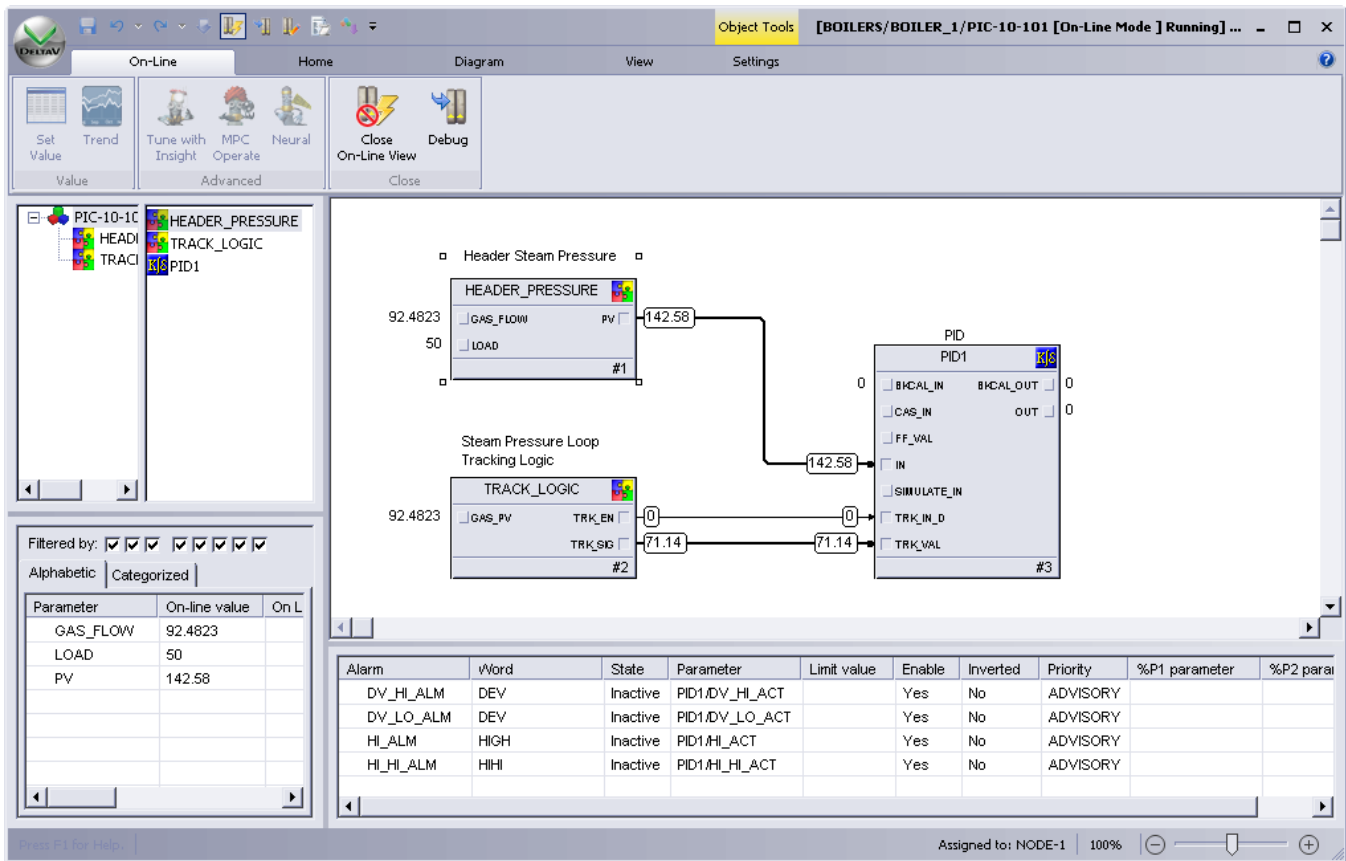

Tune and debug the strategy from this same graphical view.

Product Description

DeltaV Control Studio On-line enables you to graphically view, modify, and troubleshoot your control strategies. You can view and modify these strategies exactly the way they were configured.

Control strategy configuration is performed in Configuration Studio. Refer to the Configuration Studio product data sheet for more information.

With DeltaV software, there are *no behind-the-scenes translation programs* that convert your graphical control strategy into a different structure. The DeltaV control languages are object-oriented. Each function block, sequential step, transition, etc., is downloaded and executed as an object. This allows you to easily view and troubleshoot your strategies with the same tools used to configure.

FOUNDATION fieldbus function blocks executing in a fieldbus device are represented in Control Studio On-line just like a function block executing in a DeltaV controller or workstation. No matter where the strategy is executing, you use the same on-line view and modification capabilities. Fieldbus devices are debugged by simulating the I/O at the function block.

When you want to closely examine the performance and functionality of your control strategies, you can use Control Studio On-line. While on-line you can step through an algorithm element by element and see the specific input and output values of a block. This *allows you to solve problems quickly*, identify areas to increase performance and gain understanding of a particular function.

Control in the DeltaV system is based on modules, each module having a unique control tag. To view a module online, you need only know the name of the module, not its physical controller address.

In Control Studio, each module is treated as a separate entity. This allows you to focus on a specific module without affecting other modules that may be running in the same controller.

After you have installed a module, you can easily view its execution graphically. If you have the appropriate security privileges, you can also debug the strategy from the same graphical view. You can stop execution, execute a single step, set a break point, and perform many other functions on line.

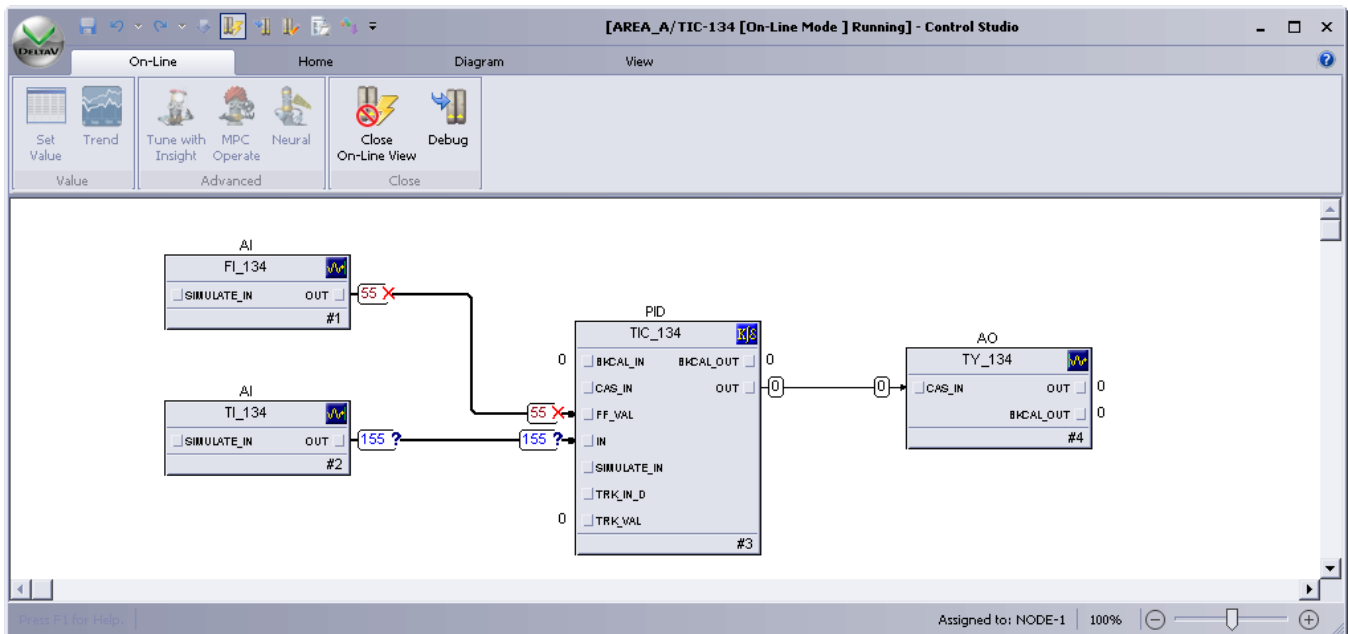

Status and errors of running strategy are marked and color-coded.

Online debugging of Function Block Diagrams (FBDs)

For your closed loop control functions and continuous calculations, Control Studio allows you to perform the following functions on-line:

- **Stop the function block diagram from executing.** This allows you to *review the strategy*

values or make a number of modifications without the control strategy's changing.

- **Advance through the complete module or individual function blocks step by step.** This allows you to analyze each function block, one at a time.
- **Set a breakpoint on a function block.** This allows you to execute the module to a particular function block.
- **Force input values.** You can use this to *override a value* if a transmitter is giving a faulty reading, or you

want to determine how your strategy will execute if the value changes.

- **Internal control strategy simulation.** You can use the simulate parameter on the function blocks and override the I/O value with a simulated value. This approach allows you to troubleshoot any of your strategies, including strategies executing in your FOUNDATION fieldbus devices.
- **Separate, non-intrusive simulation.** You can use mimic, a DeltaV product designed for I/O, and process simulation.

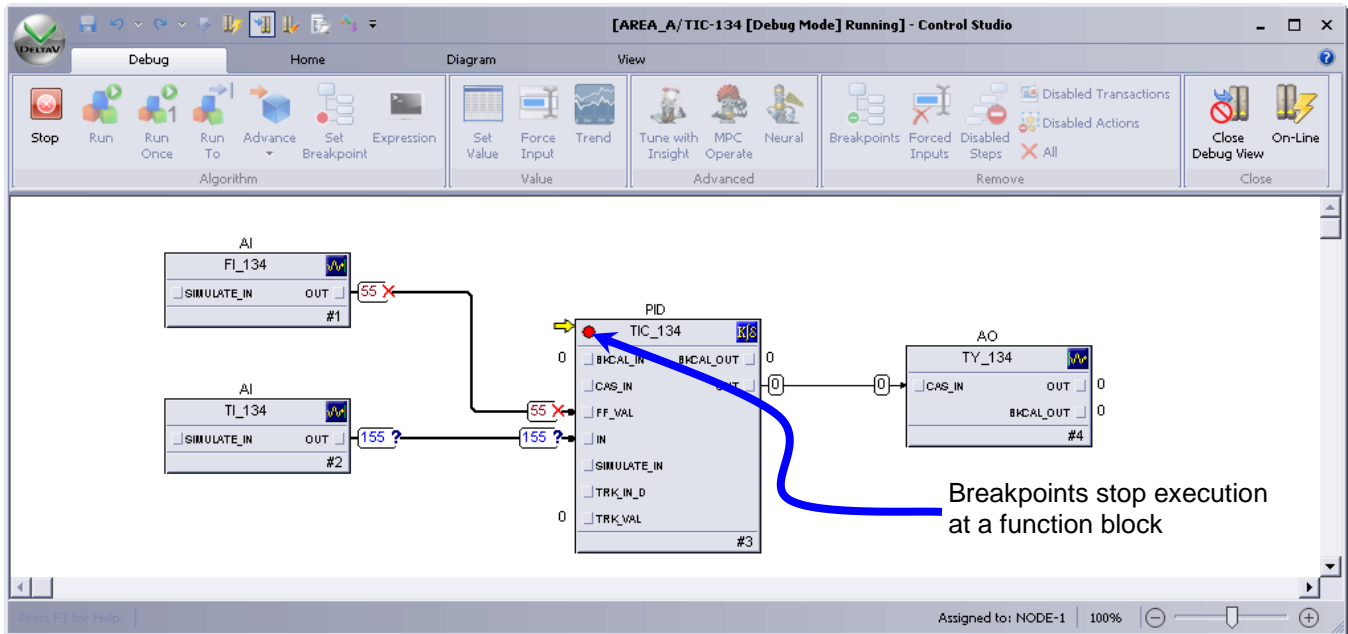

Complete set of online troubleshooting capabilities.

Online debugging of Sequential Function Charts (SFC's). For your control tasks requiring time-variant sequencing, Control Studio allows you to perform the following functions on-line:

- **Stop the SFC from executing.** This allows you to review values or make modifications without the control strategy running.
- **Disable steps, transitions, and individual step actions.** This allows you to stop at a particular transition or skip a step.
- **Force a transition to TRUE.** This allows you to skip a transition.
- **Force input values.** You can use this to override a value.
- **Activate/Deactivate steps**
- **Place the SFC in MANUAL advance.** The user has to confirm each active transition for the SFC to advance.
- **View the status of the terms** in a transition expression.

The screenshot displays the DeltaV Control Studio On-Line interface for a Sequential Function Chart (SFC) named 'MIXTANKS'. The main workspace shows the SFC diagram with the following elements:

- Steps:** INITIALIZE, RECIPE_SELECT (highlighted in green), TANK_LEVEL, ADD_INGREDIENT_1, and ADD_INGREDIENT_2.
- Transitions:** T1 (True), T2 (False), START_INITIATED (False), and START_INITIATED1 (False).
- Values:** The value 48 is associated with the RECIPE_SELECT step.

The left sidebar shows a tree view of the SFC elements. Below it, a table lists parameters and their on-line values:

Parameter	On-line value	On L
ACTIVE	True	
CONFIRM_FAIL	False	
DISABLED	False	
ERROR	False	
FAILED_CON...	0	
PENDING_CO...	0	
RERROR	False	
TIME	48	

At the bottom, a table shows the status of the current action:

Action	State	Disabled	Error	Rerror	Type	Qualifier	Time	Text
SET_RECIPE_VALUE	Complete	False	False	False	Assignment	P Pulse	0	true

View the sequence step currently executing.

Ordering Information

Description	Model Number
Control Studio On-Line	VE2161

Related Products

- **Configuration Software Suite.** Configures system components, operator interfaces, and control strategies for your system.
- **Recipe Studio.** Configures recipes (with formulations) and creates the steps for successful batch production.
- **DeltaV Tune.** Keeps in sync with your closed loop and monitor processes to determine tuning parameters.
- **AMS Device Manager.** Provides predictive diagnostics and full asset management capabilities including calibration, documentation, and device configuration for HART, FOUNDATION fieldbus, Profibus DP, and WirelessHART devices.

Prerequisites

- DeltaV Workstation.

To locate a sales office near you, visit our website at:
www.EmersonProcess.com/DeltaV
Or call us at:
 Asia Pacific: 65.777.8211
 Europe, Middle East: 41.41.768.6111
 North America, Latin America: +1 800.833.8314 or
 +1 512.832.3774

For large power, water, and wastewater applications contact Power and Water Solutions at:
www.EmersonProcess-powerwater.com
Or call us at:
 Asia Pacific: 65.777.8211
 Europe, Middle East, Africa: 48.22.630.2443
 North America, Latin America: +1 412.963.4000

© Emerson Process Management 2009. All rights reserved. For Emerson Process Management trademarks and service marks, go to: <http://www.emersonprocess.com/home/news/resources/marks.pdf>.

The contents of this publication are presented for informational purposes only, and while every effort has been made to ensure their accuracy, they are not to be construed as warranties or guarantees, express or implied, regarding the products or services described herein or their use or applicability. All sales are governed by our terms and conditions, which are available on request. We reserve the right to modify or improve the design or specification of such products at any time without notice.

