D800028X022
March 2008

SIS Accessories Installation and Safety Manual



© 1996 - 2008 Fisher-Rosemount Systems, Inc. All rights reserved. Unauthorized duplication, in whole or in part, is prohibited.

Printed in UK

Emerson, Emerson Process Management, the Emerson Process Management Design, DeltaV, the DeltaV design, and PlantWeb are marks of one of the Emerson Process Management group of companies. All other marks are property of their respective owners. The contents of this publication are presented for informational purposes only, and while every effort has been made to ensure their accuracy, they are not to be construed as warranties or guarantees, expressed or implied, regarding the products or services described herein or their use or applicability. All sales are governed by our terms and conditions, which are available on request. We reserve the right to modify or improve the design or specification of such products at any time without notice.

Contents

Safety Manual	1-5
About This Manual	1-5
Certification	1-5
Management of Functional Safety	1-5
Competence of Persons - Engineering	1-6
Competence of Persons - Installation and Hardware Maintenance	1-6
Competence of Persons - General	1-6
Restrictions	1-7
Engineering Practices	1-7
Operations and Maintenance Practices	1-7
Appendix A Common Specifications	A-1
Failure Rate Data for SIL Verification	A-1
Low Demand Mode of Operation	A-1
Worksheet Instructions	A-2
High Demand Mode of Operation	A-3
Failure Rate Data for Availability	A-4
Response Time Data	A-5
Limits	A-5
Product Life	A-5
Environmental Specifications	A-5
Appendix B Required Practices	B-1
Installation and Site Acceptance Testing	B-1
Functional Testing After the Initial Installation	B-1
Functional Testing Changes to the Installation	B-1
Proof Testing the SIS Relay and Voltage Monitor	B-2
Proof Testing the SIS Relay	B-3
Proof Testing the Voltage Monitor	B-5
Appendix C Product Specific Instructions for the SIS Relay Module	C-1
Appendix D Product Specific Instructions for the Voltage Monitor	D-1
Index	Index-1

Safety Manual

About This Manual

This document contains important information on how the SIS Relay and Voltage Monitor are used in a Safety Instrumented System (SIS) to place and/or maintain the equipment under control in an appropriate state when expected to do so. The guidelines in this document must be followed when using the SIS Relay or Voltage Monitor in a safety-critical application.

To determine whether this document is the most recent revision applicable to a particular revision of the products, compare the part number shown on the cover of this document to the part numbers shown at the following website:

<http://www.EasyDeltaV.com/SISAccessoriesSafetyManual/>

Certification

The information in this document applies to the following hardware components of the SIS Relay and Voltage Monitor.

Safety Rated

SIS Relay - Rev. A

Voltage Monitor - Rev. A

exida has certified the SIS Relay and Voltage Monitor hardware as suitable for use in applications with a maximum Safety Integrity Level of 3 (SIL3) according to IEC 61508. The SIL3 certification applies to simplex applications of the SIS Relay and Voltage Monitor.

The SIS Relay and Voltage Monitor hardware is certified for use in both the low and high demand modes of operation as defined by IEC 61508.

Refer to “Common Specifications” on page A-1 for failure rate and other data to help you verify that your safety requirements are being met and for additional considerations for using the SIS Relay or Voltage Monitor hardware in high demand mode.

Management of Functional Safety

The SIS Relay and Voltage Monitor are intended to be used in accordance with a defined safety lifecycle such as that described in IEC 61511. Emerson Process

Management recommends the following additional functional safety management requirements.

Competence of Persons - Engineering

All persons involved in the initial implementation or modification of the application software should have appropriate training. Opportunities for training include reading this manual and attending a training class taught by persons certified by Emerson Process Management. Formal training is available through Emerson Process Management Educational Services. For information, visit:

http://www.emersonprocess.com/education/contacts_centers.asp

Competence of Persons - Installation and Hardware Maintenance

All persons involved in installation and hardware maintenance activities should have appropriate training. Opportunities for training include reading this manual and attending a training class taught by persons certified by Emerson Process Management. Formal training is available through Emerson Process Management Educational Services.

Competence of Persons - General

All persons involved in any aspect of SIS Relay or Voltage Monitor use, including engineers, operators, supervisors, and maintenance personnel should have training in the importance of Safety Instrumented Systems. All persons should have specific training in the procedures for which they are responsible.

For technical support contact information, visit:

<http://www.emersonprocess.com/systems/support/ratecard.htm>

To report and return failed hardware, please contact the Global Service Center (GSC) for technical support prior to contacting Customer Service for a Material Return Tracking (MRT) number. The GSC will help determine the necessary actions and forward the call to Customer Service if needed.

Restrictions

The practices required in the use of the Voltage Monitor and SIS Relay are summarized below. Each topic is discussed in greater detail in Appendix B.

- You must complete a full functional test of the SIS Relay and Voltage Monitor hardware before it is used to provide the protection function in a running process.
- The SIS Relay and Voltage Monitor are designed for a de-energized to trip operation such that the tripped state for the process is achieved when the output channels are de-energized.

Engineering Practices

The SIS Relay and Voltage Monitor products must be used within the published specifications.

Refer to “Common Specifications” on page A-1 for more information on safety relevant specifications for the SIS Relay and Voltage Monitor products.

Operations and Maintenance Practices

You must conduct a periodic proof test of each SIS Relay and Voltage Monitor channel to reveal potential dangerous faults not detected by continuous runtime diagnostics in the safety PLC. The necessary frequency of the proof test is a function of the required probability of dangerous failure for the safety instrumented function(s) associated with the SIS Relay or Voltage Monitor. The proof test is conducted by manual Proof Test momentary contact switches.

Refer to “Required Practices” on page B-1 for more information on proof testing. Appendix B also contains additional topics on recommended operations and maintenance practices for the SIS Relay and Voltage Monitor.

Appendix A Common Specifications

Failure Rate Data for SIL Verification

In order to verify that a Safety Instrumented Function (SIF) meets the required safety integrity level (SIL) you must determine the probability of the SIF failing dangerously. The tables in this section contain failure rate data for estimating the probability of the SIF's Logic Solver subsystem failing dangerously. Third party tools are available for estimating the probability of failure associated with the SIS Relay and Voltage Monitor products. For more information, refer to:

<http://www.EasyDeltaV.com/SISAccessoriesSafetyManual/>

Low Demand Mode of Operation

In the low demand mode of operation, the proof test frequency is at least twice the expected demand rate. Stated another way, the periodic proof test occurs at regular intervals at least twice during the expected time between demands.

SIL verification for the low demand mode uses the Average Probability of Failure on Demand (PFDavg) for the SIF. You can use the failure rate data in Table A-1 to estimate the PFDavg for the Voltage Monitor and SIS Relay components for the SIF.

The Worksheet for Approximating the SIS Relay and Voltage Monitor DU Failure Rate Contribution for a SIF (see Table A-1) is used to estimate the total dangerous undetected (DU) failure rate of the SLS1508 subsystem of the SIF. The DU failure rate is a function of the number of Voltage Monitors and SIS Relays involved in the SIF. This calculation would normally take dangerous detected (DD) faults into account. However as stand-alone units, the Voltage Monitor and SIS Relay do not have the capability to perform self-diagnosis, so this term becomes 0.

Worksheet Instructions

- Enter the number of SIS Relays that drive output channels in this SIF.
- Multiply the number of SIS Relays by the DU failure rate (failures per hour) and enter the result. Sum the results to get the total DU failure rate.
- Enter the number of Voltage Monitors that are used as safety critical inputs in this SIF.
- Multiply the number of SIS Relays and Voltage Monitors by the DU failure rate (failures per hour) and enter the result. Sum the results to get the total DU failure rate contribution for this SIF from SIS Relays and Voltage Monitors.

Table A-1 Worksheet for Approximating the SIS Relay and Voltage Monitor DU Failure Rate Contribution for a SIF

Number of SIS Relays driving output channels in this SIF.		X	1.75E-11 (0.0175 FITS)	=	
Number of Voltage Monitor channels driving input channels in this SIF.		X	7.2E-10 (0.72 FITS)	=	
Total DU failure rate (failures per hour)					

You can approximate the PFDavg contribution of the SIS Relay and Voltage Monitor subsystems using the total failure rates in Table A-1, the proof test period for the SIS Relays and Voltage Monitor channels in the SIF, and your maximum allowed repair time.

$$\text{PFDavg (LS)} = \lambda \text{ DU} * T/2 + \lambda \text{ DD} * \text{RT}$$

where:

$\lambda \text{ DU} =$	Total DU failure rate from Table A-1, "Worksheet for Approximating the SIS Relay and Voltage Monitor DU Failure Rate Contribution for a SIF" on page A-2
$T =$	Proof test period in hours.
$\lambda \text{ DD} =$	Total DD failure rate for each product. (0.0 in this case).
$\text{RT} =$	Allowed repair time in hours.

Determine the PFDavg for the SIF by summing the PFDavg for the SIS Relay and Voltage Monitor channels with the PFDavg for the Logic Solver subsystem plus the sensor and final element subsystems.

High Demand Mode of Operation

In the high demand mode, the periodic proof test does not occur at least twice during the expected demand interval, but the demand interval is sufficiently longer than the fault detection and reaction time. SIL verification for the high demand mode uses the Probability of Dangerous Failure per Hour (PFH).

There are several additional considerations when operating in the high demand mode. Generally it is easy to avoid operating in high demand mode by reducing the proof test interval on the SIS Relay and Voltage Monitor. But if there is a practical constraint in the proof testing frequency of another subsystem of the SIF that causes the SIF to operate in the high demand mode, the additional considerations of high demand mode apply.

As the SIS Relay and Voltage Monitor are simple products without any online diagnostics, limitations on the use of high demand mode are most likely determined by the Logic Solver, sensor, and final element subsystems.

The PFH for the SIS Relay or Voltage Monitor subsystems of the SIF is the total DU failure rate from Table A-1, "Worksheet for Approximating the SIS Relay and Voltage Monitor DU Failure Rate Contribution for a SIF" on page A-2.

$$\text{PFH (SIS Relay and Voltage Monitor Channels)} = \lambda \text{ DU}$$

where:

λ_{DU} = Total DU failure rate from Table A-1, "Worksheet for Approximating the SIS Relay and Voltage Monitor DU Failure Rate Contribution for a SIF" on page A-2

Determine the PFDavg for the SIF by summing the PFH for the SIS Relay and Voltage Monitor channels with the PFH for the Logic Solver subsystem plus the sensor and final element subsystems.

Failure Rate Data for Availability

The Mean Time to Failure Spurious (MTTFS) is a measure of the time between failures that result in a process shutdown. It takes into account safe failures that can cause outputs to de-energize and the dangerous detected failures that cause the Logic Solver to de-energize its outputs.

MTTFS	
SIS Relay	>3000 years
Voltage Monitor	>1600 years

Not all safe failures result in a process shutdown. A safe failure on an Voltage Monitor input channel or SIS Relay output will not necessarily cause a trip (if it is part of a 2oo3 voting arrangement, for example).

MTTFS for a SIF due to the SIS Relay or Voltage Monitor is a function of the number and type of channels involved. You can estimate MTTFS of a SIF due to these subsystems by dividing the number of years by the number of SIS Relays and Voltage Monitors involved in the SIF.

Response Time Data

The response time for a SIF must be less than the process safety time. The SIF has a response time associated with the sensor, Logic Solver, and final element subsystems in addition to the contributions from the SIS Relays and Voltage Monitors. The sum of the response times must be less than the process safety time. The response time of the SIS Relay or Voltage Monitor subsystem is the time between any change on a SIF input to one of these devices that should result in a trip and the time that the output channel or channels change to the tripped state. The time is measured from screw terminal to screw terminal.

The response time for each individual component is listed in the specification tables in Appendix C and Appendix D.

Limits

Product Life

The lifetime limit of the Voltage Monitor and SIS Relay is 20 years based on the worst case component wear-out.

Environmental Specifications

The environmental specifications for normal operation of the Voltage Monitor and SIS Relay are:

- Operating temperature: -40°C to 70°C (-40°F to 158°F)
- Storage temperature: -40°C to 85°C (-40°F to 185°F)
- Relative humidity: 5% to 95% non-condensing
- Shock: 10 g ½-sine wave for 11 ms
- Vibration: 1 mm peak-to-peak from 5 to 16 Hz; 0.5g from 16 to 150 Hz
- Airborne contaminants: Severity level G3
- IP 20 rating
- Electromagnetic compatibility: Per EN61326 (Class A Emissions; Annex A Immunity for Essential Operation) and Namur NE21

Appendix B Required Practices

This section contains additional information on required practices as they relate to restrictions in the use of the SIS Relay and Voltage Monitor products.

Installation and Site Acceptance Testing

Installation of the Voltage Monitor and SIS Relay must conform to the guidelines in Appendix C and Appendix D of this document. For convenience, the installation instructions are repeated in the *Installing Your Delta V™ Safety Instrumented System Hardware* manual.

Your site acceptance procedures should include functional testing of the application programs using the SIS Relay or Voltage Monitor.

Functional Testing After the Initial Installation

Warning You must complete a full functional test of the SIS Relay and Voltage Monitor before it is allowed to provide the protection function in a running process.

After an initial installation of a SIS Relay or Voltage Monitor, you must ensure that all the output channels respond appropriately:

- as you manipulate the value of input channels on the safety PLC
- to safety relevant changes to external conditions monitored as part of a SIF

The functional test is required even if the identical logic has already been tested in an identical configuration.

Functional Testing Changes to the Installation

If any changes are made to the SIS Relay or Voltage Monitor installation you must complete a full functional test of the SIS Relay and Voltage Monitor before it is allowed to provide the protection function in a running process.

Proof Testing the SIS Relay and Voltage Monitor

The SIS Relay and Voltage Monitor have built-in proof test capability to support guidelines set forth in the IEC 61511 standard. As both the SIS Relay and Voltage Monitor contain internal fault tolerance circuits, it is important to use the built-in proof test capability to ensure full proof test coverage of all potential faults which may result in dangerous or degraded safety performance.

Online proof testing of the SIS Relay or Voltage Monitor may result in a false trip of the associated SIF. If online testing is performed, it is the user's responsibility to implement measures sufficient to maintain safety and prevent a false trip for the duration of the proof testing operation or first take the EUC to a safe state prior to performing the proof test.

Note

To support the safety life cycle, it is the user's responsibility to document that a periodic inspection or proof test has been completed. The results of the test should be recorded and saved.

Proof Testing the SIS Relay

The SIS Relay must be proof tested periodically to ensure there are no dangerous faults present that are not detected by normal operation. A manual proof test for a SIS Relay is to be performed by personnel in direct proximity of the SIS Relay module.

Immediately following successful power-up testing there are no known dangerous faults present. Choose the proof test interval for a SIS Relay for a particular SIF to achieve the required probability of dangerous failure for the SIF.

Note

You can claim a proof test coverage of 100% by following the proof test sequence documented below.

It is important that you proof test all three relays individually. A circuit that does not open when the switch is toggled indicates a stuck contact. If this occurs, replace the module.

It is the user's responsibility to by-pass the field circuit during proof testing if required.

Proof Testing the SIS Relay for AC Wiring

Proof test sequence:

1. Measure the voltage at the AC field device's + and - connections (screw terminals 9 and 11). The voltage at these points should match the input voltage.
2. Slide the switch labeled Test 1 down to toggle it and then measure the voltage at the AC field device's + and - connections (screw terminals 9 and 11). The voltage at these points should be 0 when toggled. Release the toggle and re-measure the voltage.
3. Slide the switch labeled Test 2 down to toggle it and then measure the voltage at the AC field device's + and - connections (screw terminals 9 and 11). The voltage at these points should be 0 when toggled. Release the toggle and re-measure the voltage.
4. Slide the switch labeled Test 3 down to toggle it and then measure the voltage at the AC field device's + and - connections (screw terminals 9 and 11). The voltage at these points should be 0 when toggled. Release the toggle and re-measure the voltage.

Proof Testing the SIS Relay for DC Wiring

Warning

Note that proof testing of the SIS Relay test both DC switched DC outputs at the same time so that testing of either channel will result in a trip of the other channel unless specific actions are taken to prevent it. If online testing is performed it is the users responsibility to implement measures sufficient to maintain safety and prevent a false trip for the duration of the proof testing operation or first take the EUC to a safe state prior to the proof test being performed.

Proof test sequence:

1. Measure the voltage at the first DC field device's + and - connections (screw terminals 9 and 10). The voltage at these points should match the input voltage.
2. Slide the switch labeled Test 1 down to toggle it and then measure the voltage at the DC field device's + and - connections (screw terminals 9 and 10). The voltage at these points should be 0 when toggled. Release the toggle and remeasure the voltage.
3. Slide the switch labeled Test 2 down to toggle it and then measure the voltage at the DC field device's + and - connections (screw terminals 9 and 10). The voltage at these points should be 0 when toggled. Release the toggle and remeasure the voltage.
4. Slide the switch labeled Test 3 down to toggle it and then measure the voltage at the DC field device's + and - connections (screw terminals 9 and 10). The voltage at these points should be 0 when toggled. Release the toggle and remeasure the voltage.

If you have a second DC field device, perform steps 1-4 by measuring the voltage at pins 11 and 12.

Proof Testing the Voltage Monitor

The Voltage Monitor must be proof tested periodically to ensure there are no dangerous faults present that are not detected by normal operation. A manual proof test for a Voltage Monitor channel is to be performed by personnel in direct proximity to the Voltage Monitor.

Immediately following successful power-up testing there are no known dangerous faults present. Choose the proof test interval for a Voltage Monitor channel for a particular SIF to achieve the required probability of dangerous failure for the SIF.

Note

You can claim a proof test coverage of 100% by following the proof test sequence documented below.

The output to the Safety PLC Input channels is based on a simple Type A design with built in proof test support hardware. An output circuit that does not go to the de-energized state when the switch is toggled to the test position indicates a stuck contact. If this occurs, replace the Voltage Monitor.

Proof test sequence:

Perform the following proof test sequence for every Voltage Monitor channel used in the associated SIF being proof tested:

1. Monitor the reported state of the Voltage Monitor output of channel 1 or 2 as read by the associated Safety PLC Input.
2. Verify the input associated with the Voltage Monitor channel to be proof tested initially represents the energized state.
3. Slide the switch labeled CHAN 1 or CHAN 2 to the Test A position and verify Voltage Monitor output for the appropriate channel changes to the de-energized state.
4. Release the switch to its original position and verify Voltage Monitor output for the appropriate channel returns to the energized state.
5. Slide the switch labeled CHAN 1 or CHAN 2 to the Test B position and verify Voltage Monitor output for the appropriate channel changes to the de-energized state.
6. Release the switch to its original position and verify Voltage Monitor output for the appropriate channel returns to the energized state.

Appendix C Product Specific Instructions for the SIS Relay Module

The SIS Relay module is suitable for use in both high and low de-energize to trip safety critical applications to extend the voltage and current capability of the DeltaV SLS1508 or any other safety PLC 24VDC discrete output without compromising safety integrity. It is capable of switching up to 2.5A at 250 VAC or 2.5A at 24 VDC for safety applications following de-energize to trip conventions by disconnecting field power when de-energized.

Two sets of output switches are provided controlled by one common input. DC mode of operation is configured to provide two independent sets of DC input power while the AC mode of operation is configured to switch both sides of the AC input power.

The SIS Relay module contains three relays from different manufacturers. A relay coil is energized for all three relays in normal operation. If a demand occurs, the SLS removes the power from the coil for all three relays at the same time. Each relay can be proof tested in the field. Refer to “Proof Testing the SIS Relay” on page B-3.

AC Field Wiring

Refer to Figure C-1 for AC field wiring connections.

- Two pin discrete input connection for input from an SLS or generic safety PLC 24VDC Discrete Output channel
- Two pin connections for input from an AC power source
- Two pin connections for the switched AC output to an AC field device

DC Field Wiring

Refer to Figure C-2 for DC field wiring connections.

- Two pin discrete input connection for input from an SLS or generic safety PLC 24VDC Discrete Output channel
- Four pin connection for input from two DC power sources
- Four pin connection for the switched outputs to two DC field devices

The SIS Relay module’s LED shows the state of the relay coil if the discrete input is correctly connected to the PLC output. The LED is illuminated when the relays are energized and supplying power through the switched power outputs.

Table C-1 shows the specifications for the SIS Relay module.

Table C-1 SIS Relay Module Specifications

Item	Specification
Input for energized relay	> 18VDC
Input for de-energized relay	< 6VDC
Input current at 24 VDC	< 70 mA
Relay current rating for AC operation	2.5A @ 250 VAC
Relay current rating for DC operation Note: When used in switched applications where transients and current are limited.	2.5A @ 30 VDC
Maximum AC Source	280 VAC
Maximum DC Source	30 VDC
Output series impedance (energized state)	< 0.5 Ω
Output series impedance (de-energized state)	> 1 M Ω
Maximum DC source 1 to source 2 potential	100 V
Input to Output isolation rating	300 VAC
Input to output delay (de-energize)	10 msec
Input to output delay (energize)	12 msec
Mounting configuration	Horizontal DIN rail
Lifetime limitation on number of relay cycles	>30,000 cycles or 20 years

The dimensions for the SIS Relay are the same as the Voltage Monitor (see Figure D-1). Figure C-1 shows the SIS Relay module's connections for AC wiring.

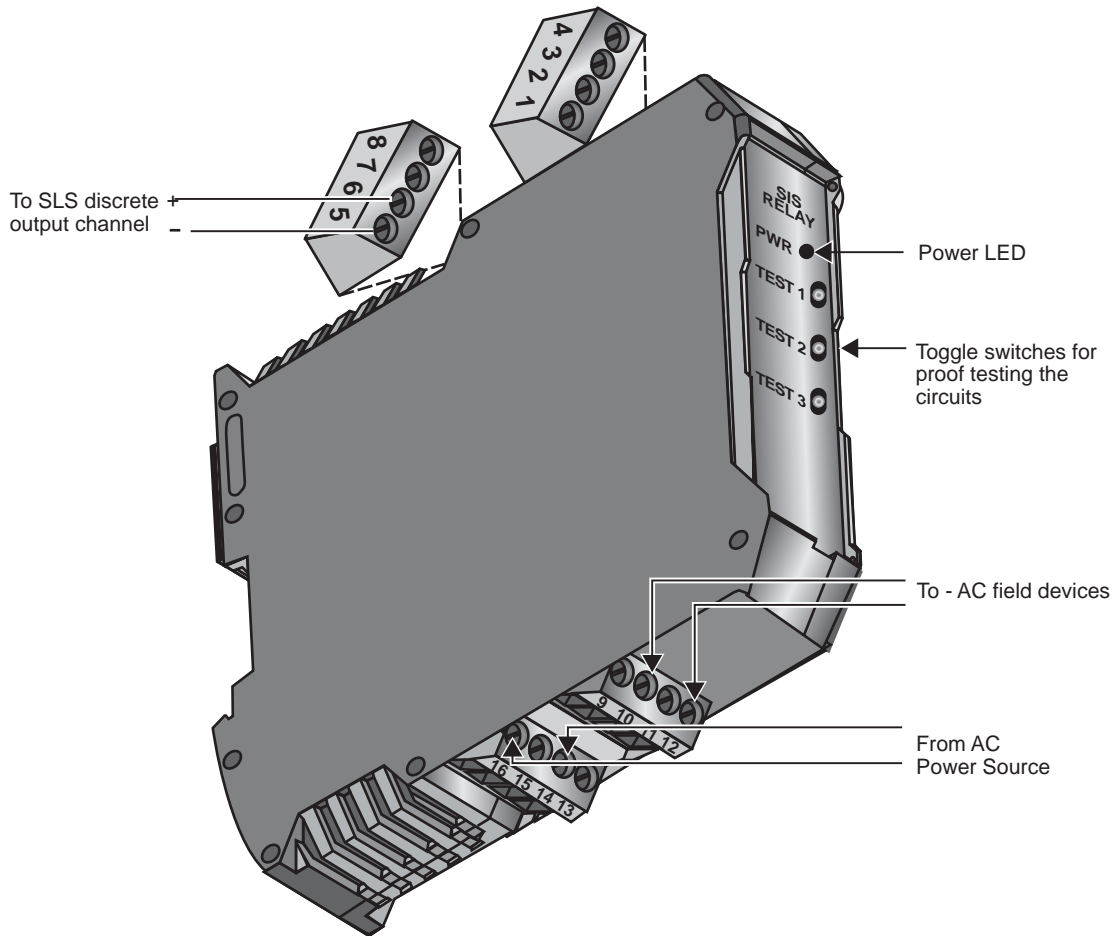

Figure C-1 SIS Relay Module for AC Field Wiring

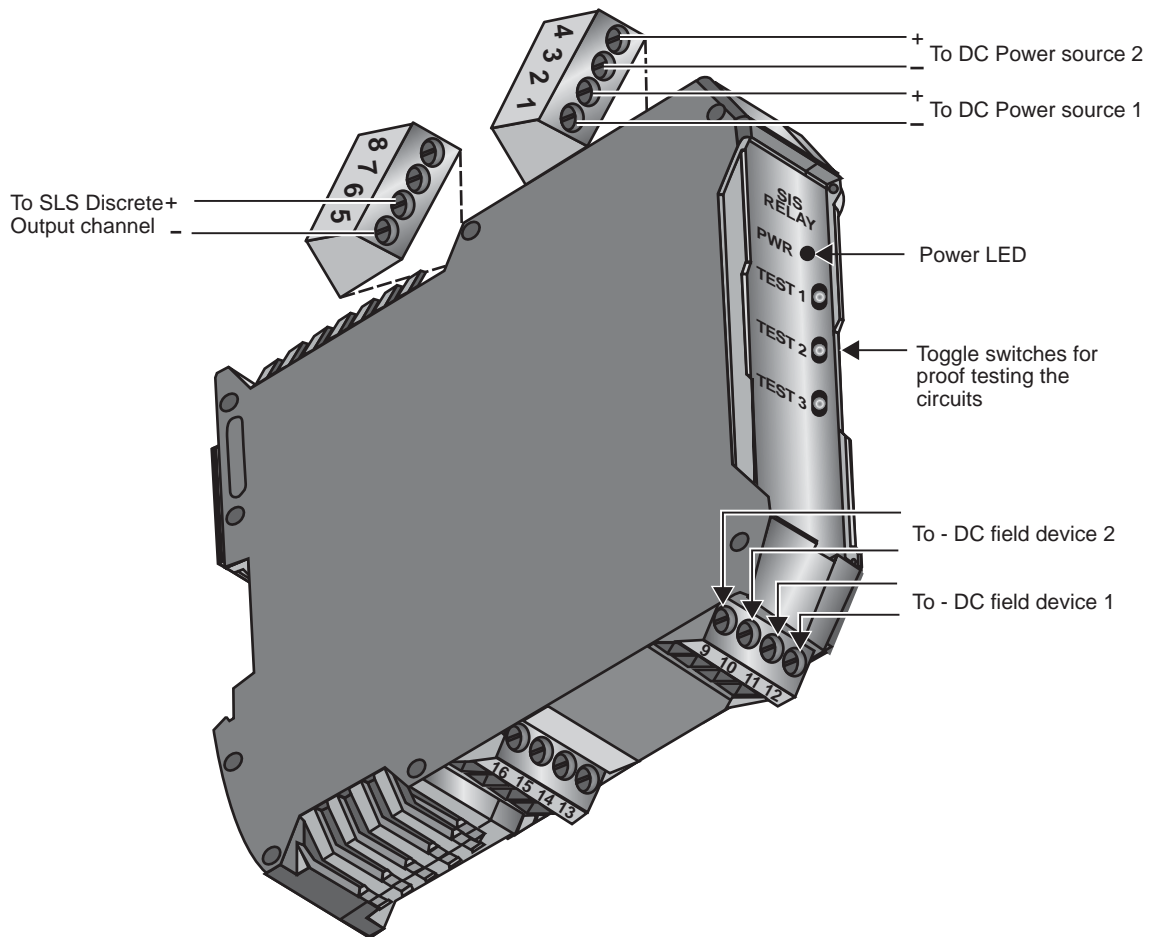

Figure C-2 SIS Relay Module for DC Field Wiring

Appendix D Product Specific Instructions for the Voltage Monitor

The Voltage Monitor provides two independent sets of voltage monitoring circuitry in one device where each is suitable for use in both high and low de-energize to trip applications to extend the voltage input monitoring capability of the DeltaV SLS1508 or any other safety PLC discrete input compatible with its specified output states. It also supplies a secondary output for non-safety critical monitoring for each input.

The state of both outputs for an associated input is controlled by the voltage level of the input with the outputs going to the de-energized state when the input goes below a specified value.

It is designed to be used with DeltaV SLS1508 to drive a Logic Solver's Discrete Input channel or a Series 2 DI Dry Contact channel based on the output of the SIS Relay module. Refer to Figures D-1 and D-2. The Voltage Monitor has the following connections:

- Two four pin connection blocks, one for each voltage monitoring channel for connection to DC or AC power source being monitored
- Two four pin connection blocks, one for each voltage monitoring channel for connecting the output to a SLS or other safety PLC monitored DI channel and a DI, Dry Contact channel

Table D-1 shows the specifications for the Voltage Monitor.

Table D-1 Voltage Monitor Specifications

Item	Specification
Input for energized output	>18 VDC or > 80 VAC
Input for de-energized output	<3 VDC or <3 VAC
Maximum input voltage rating	250 VAC
Input current at 24 VDC	<6 mA
Input current at 120 VAC	<12mA
Input current at 230 VAC	<15 mA
Output impedance (energized state)	< 3.5 K Ω
Output impedance (de-energized state)	>8.5 K Ω
Maximum output voltage rating	30 VDC
Input to output isolation rating	250 VAC
Safety output to Dry Contact isolation rating	30 VAC
Channel-to-channel isolation rating	250 VAC
Input to output delay (de-energize)	30 msec
Input to output delay (energize)	5 msec
Mounting configuration	Horizontal DIN rail
Lifetime limitations	30,000 cycles or 20 years

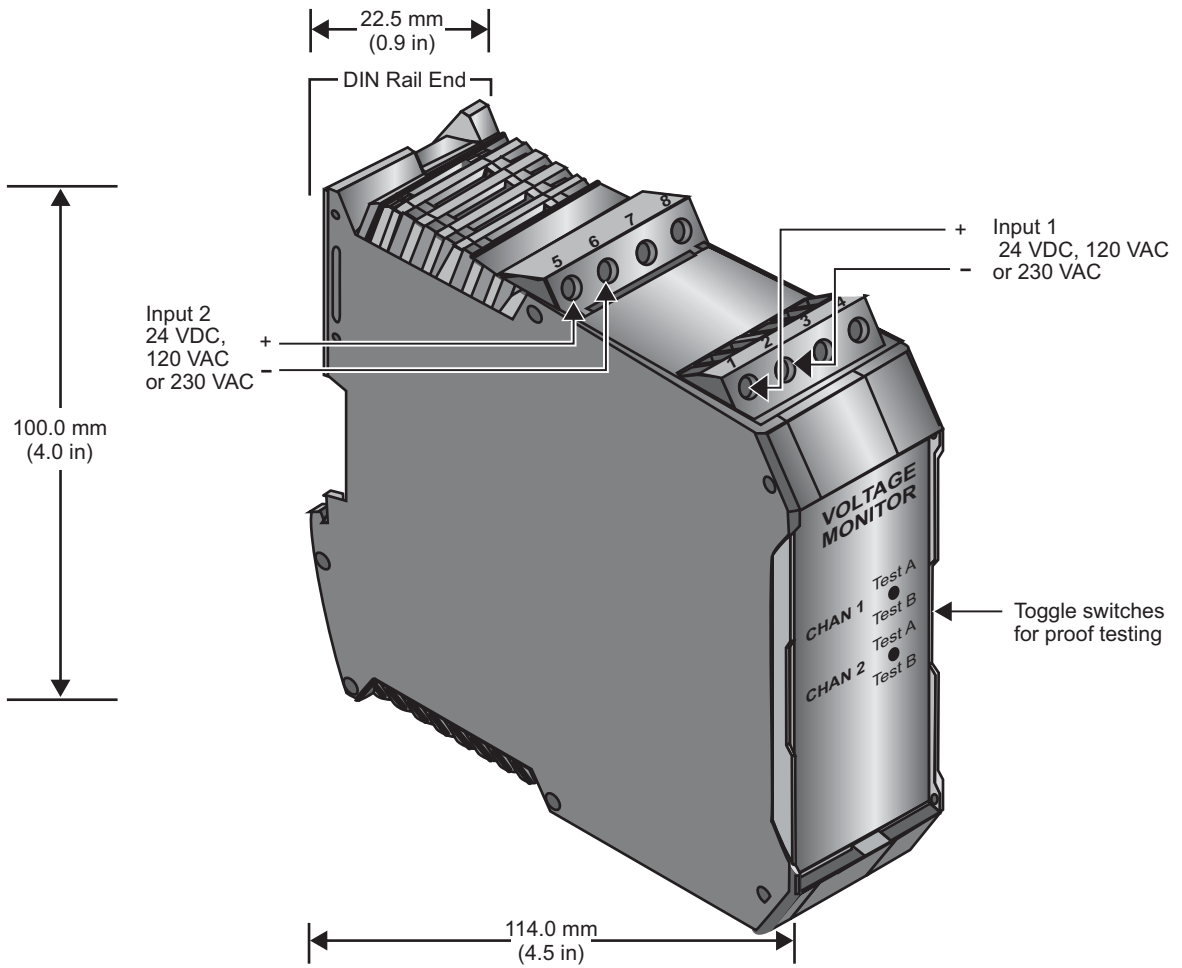

Figure D-1 Voltage Monitor Top View and Dimensions

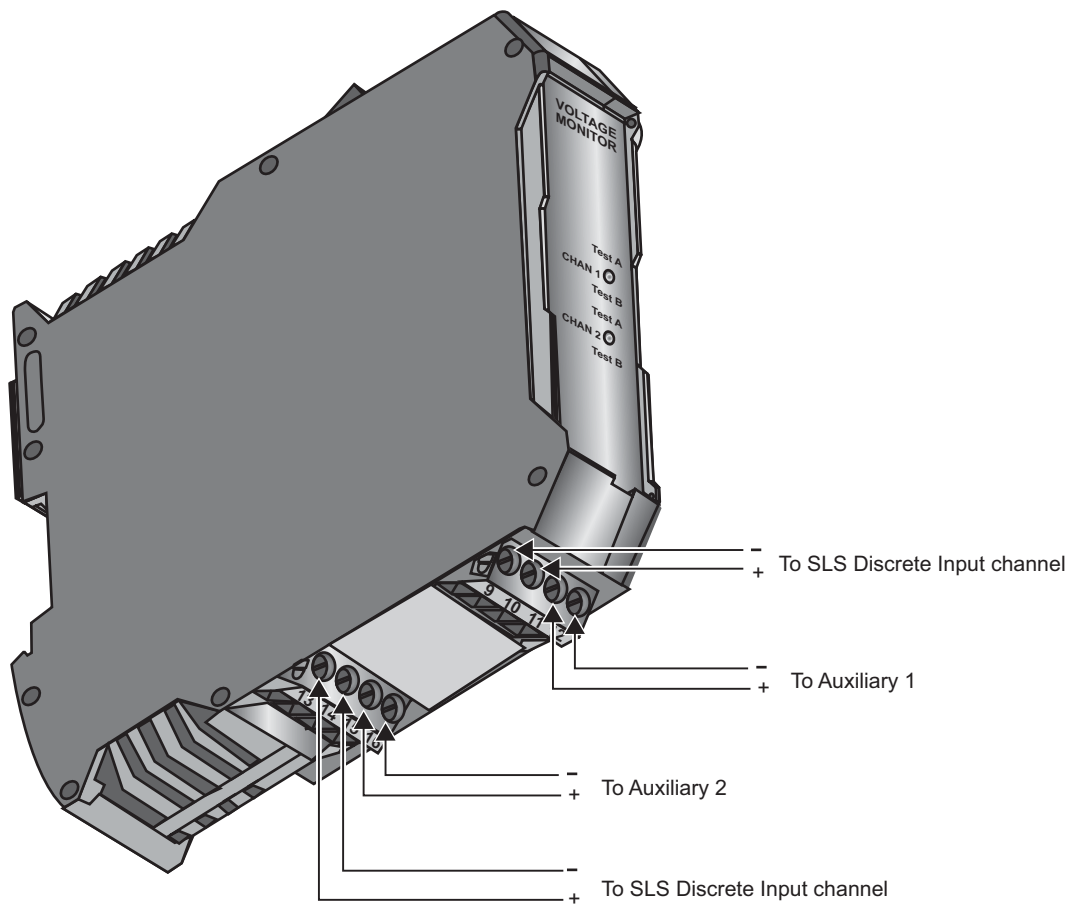

Figure D-2 Voltage Monitor Bottom View

Index

- A**
 - AC field wiring
 - connections for C-1
 - Airborne contaminants A-5
 - Average Probability of Failure on Demand A-1
- C**
 - Certifications 1-5
- D**
 - DC field wiring
 - connections for C-1
 - Dimensions D-3
 - Document revision 1-5
 - DU failure rate
 - estimating A-1
- E**
 - Electromagnetic compatibility A-5
 - Engineering practices 1-7
 - Environmental specifications A-5
- F**
 - Failed hardware
 - returning 1-6
 - Failure rate data A-1
 - Functional safety management requirements 1-6
 - Functional testing B-1
- H**
 - Hardware revisions 1-5
 - High demand mode 1-5
 - considerations for operating in A-3
 - Humidity A-5
- I**
 - Installation and hardware maintenance
 - training 1-6
- L**
 - Lifetime limit A-5
- M**
 - Maintenance practices 1-7
 - Mean Time to Failure Spurious A-4
 - MTTFS A-4
- O**
 - Operating temperature A-5
- P**
 - PFDAvg A-3
 - PFH A-3
 - Probability of Dangerous Failure per Hour A-3
 - Proof testing B-2
- R**
 - Relative humidity A-5
 - Required practices 1-7
 - Response time A-5
 - Returning failed hardware 1-6
 - Revisions
 - document and hardware 1-5
- S**
 - Shock A-5

SIF

response time for A-5

SIL verification

failure rate data A-1

SIS Relay

dimensions D-3

environmental specifications A-5

functional testing B-1

proof testing B-2

response time A-5

restrictions for using 1-7

site acceptance procedures B-1

specifications C-1

Site acceptance procedures B-1

Specifications

SIS Relay C-1

Voltage Monitor D-1

Storage temperature A-5

T

Training 1-6

V

Vibration A-5

Voltage Monitor

dimensions D-3

environmental specifications A-5

functional testing B-1

proof testing B-2

response time A-5

restrictions for using 1-7

site acceptance procedures B-1

specifications D-1