

Analysis of Pipeline-Quality Gas using a C9: Application (Five-Minute Analysis)

www.daniel.com

Emerson Process Management's on-line chromatographs provide custody-transfer measurement of energy content in natural gas. To determine this heating value component, first we must determine component concentrations. In a standard C6+ application, this analysis is performed using two valves in a single oven (12-minute analysis time) or three valves in a single oven (four-minute analysis time). To perform this analysis to C9+, five valves are used in two different ovens (five-minute analysis time).

The results from both detectors are combined in post-analysis calculations and reported together.

Industry Background

Deregulation of the natural-gas industry, coupled with high demand, has caused the composition of natural gas to be less consistent in recent years. Pipelines can now carry gas from a variety of sources, as market forces dictate. Furthermore, the increased demand of natural gas, mostly attributed to increased electricity requirements and air-pollution standards, has expanded the number of gas fields and producers. Much of the new gas comes from Canada and the Northwestern US and is quite rich (gas with higher concentrations of relatively heavier hydrocarbons). Additionally, during periods when natural gas prices rise (such as winter periods), the gas may not be processed — leaving the heavier hydrocarbon gasses (butane, propane, ethane — that would have normally been removed and sold) in the pipeline.

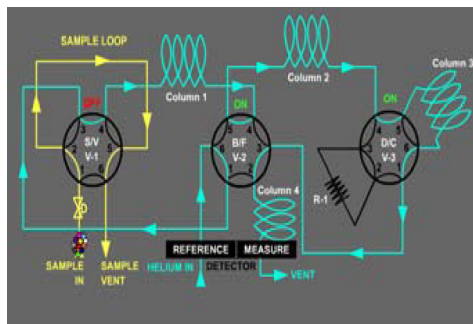

Figure 1. Oven 1 is used for measurement of C1-C2, N2 and CO2

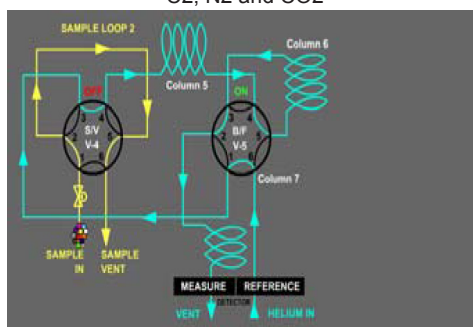

Figure 2. Oven 2 is used for measurement of C6, C7, C8 and C9+

Using a C9+ extended analysis gas chromatograph at these rich-gas custody transfer points enables a more accurate measurement than a standard C6+ analysis. Rather than assuming fixed percentages of the C6+ peak (as the C6+ application does per 2261), a C9+ analysis separates and measures the component hydrocarbon groups of C6, C7, C8, and C9+.

Analysis Method

This analysis is performed with two ovens — each with a thermal conductivity detector (TCD) pair and column set. The first oven measures nitrogen, methane, carbene dioxide, and ethane up to C6. The second oven uses two valves and three column sets and separates and measures heavier hydrocarbon component groups of C6 to C9+. Both measurements are made simultaneously in under five minutes.

Since there are many different components for each carbon number, some of the components within a given carbon number are completely separated from each other, and some are partially separated. Their collective peak areas are all calculated and summed in what is called forced integration. This is a forced on and off time for all peaks to be integrated. The sum of all peak areas is then reported as the total peak area for that particular carbon number. The response factor is then used for further calculations to determine mole percentage.

Calibration

The calibration procedure and the calibration standard used are more complex and costly than the C6+ application. The application is simplified, however, because the extended component mixture contains only the normal components. For example, normal hexane is the only C6 component used in the calibration mixture. Columns are chosen that elute the normal components last, thus allowing easier set up of the forced integration off time for that carbon number group. It also allows for setting the forced integration on time for the next carbon number group. A common response factor calculated from the detector's response to the normal component and used for all components in that carbon number group. There are several advantages with this method.

- The cost of calibration standard is reduced
- The calibration is simplified to allow for automatic calibration in most cases
- The calibration standard and transport tubing can be installed without heat tracing (in most climates) to ensure complete vaporization of all components because the mole fraction of the heavier components is reduced
- Increased volume can be contained within the same calibration bottle for the same price. The mixture can withstand higher pressures and remain in the vapor phase due to the reduced volume of heavier components
- Thermal conductivity detectors (TCDs) can be used for trace component analysis. TCDs operate with far less maintenance than alternate flame ionization detectors (FIDs), which also require hydrogen and combustion air. Emerson offers TCDs with increased sensitivity to measure the lower concentrations of the heavier components.

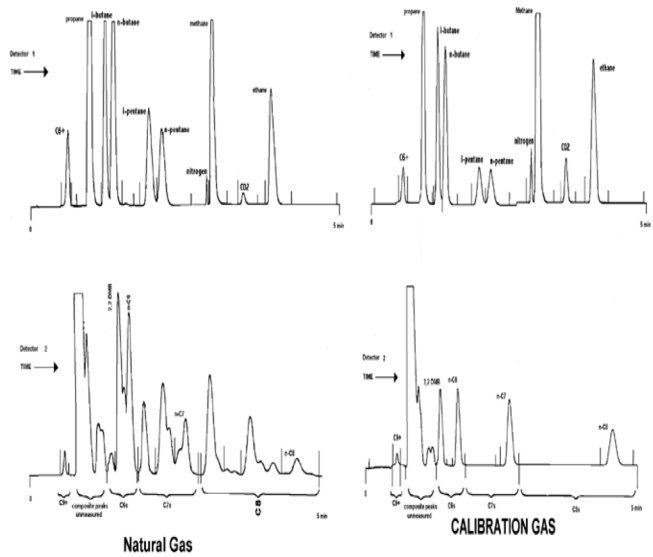

Component		Range
C9+	Nonanes and heavier	(0-0.05%)*
C8+	Octanes	(0-0.1%)*
C7+	Heptanes	(0-0.2%)*
C6+	Hexanes and heavier	(0-0.5%)*
C3	Propane	(0-5%)*
IC4	Isobutane	(0-1%)*
NC4	Normal Butane	(0-1%)*
NeoC5	Neopentane	(0-1%)*
IC5	Isopentane	(0-1%)*
NC5	Normal Pentane	(0-1%)*
N2	Nitrogen	(0-15%)
C1	Methane	(0-100%)
CO2	Carbon Dioxide	(0-15%)
C2	Ethane	(0-15%)
H2S	Hydrogen Sulfide	(0-30 ppm)

* Heavier concentrations can be measured but may require a heated sampling system to prevent drop-out

Emerson Process Management
Daniel Measurement and Control, Inc.
www.daniel.com

North America / Latin America:
Headquarters
USA - Houston, Texas
T +1.713.467.6000
F +1.713.827.3880
USA Toll Free 1.888.FLOW.001

Europe: Stirling, Scotland, UK
T +44.1786.433400
F +44.1786.433401

Middle East, Africa: Dubai, UAE
T +971.4.811.8100
F +971.4.886.5465

Asia Pacific: Singapore
T +65.6777.8211
F +65.6777.0947 / 0743

Daniel Measurement and Control, Inc. is a wholly owned subsidiary of Emerson Electric Co., and a division of Emerson Process Management. The Daniel name and logo are registered trademarks of Daniel Industries, Inc. The Emerson logo is a registered trademark and service mark of Emerson Electric Co. All other trademarks are the property of their respective companies. The contents of this publication are presented for informational purposes only, and while every effort has been made to ensure their accuracy, they are not to be construed as warranties or guarantees, expressed or implied, regarding the products or services described herein or their use or applicability. All sales are governed by Daniel's terms and conditions, which are available upon request. We reserve the right to modify or improve the designs or specifications of such products at any time. Daniel does not assume responsibility for the selection, use or maintenance of any product. Responsibility for proper selection, use and maintenance of any Daniel product remains solely with the purchaser and end-user.

