

Model V2700-20 Aggressive Product (AP) Cylinder Assembly for 700 Series Valves

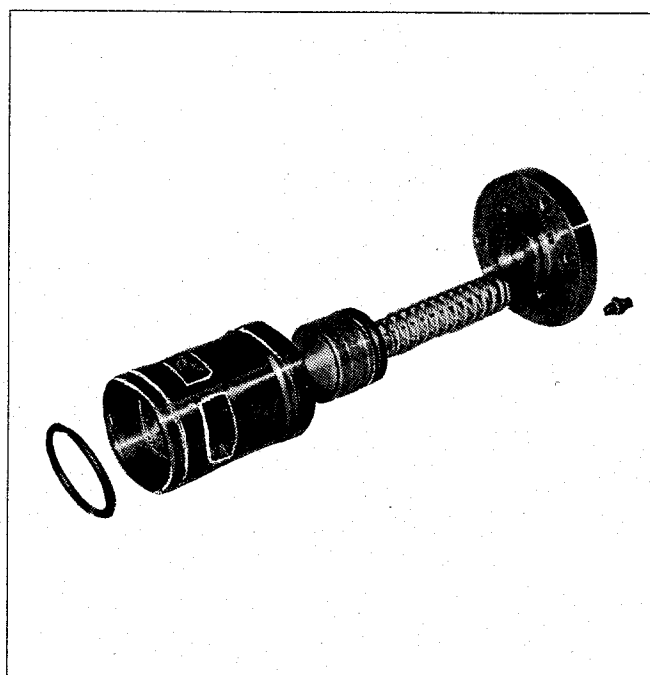

Brooks Instrument

FISHER-ROSEMOUNT

Essential Instructions

Read this page before proceeding!

Brooks Instrument designs, manufactures and tests its products to meet many national and international standards. Because these instruments are sophisticated technical products, you must properly install, use and maintain them to ensure they continue to operate within their normal specifications. The following instructions must be adhered to and integrated into your safety program when installing, using and maintaining Brooks Products.

- Read all instructions prior to installing, operating and servicing the product. If this instruction manual is not the correct manual, telephone Brooks, Hatfield at 215-362-3500 and the requested manual will be provided. Save this instruction manual for future reference.
- If you do not understand any of the instructions, contact your Brooks Instrument representative for clarification.
- Follow all warnings, cautions and instructions marked on and supplied with the product.
- Inform and educate your personnel in the proper installation, operation and maintenance of the product.
- Install your equipment as specified in the installation instructions of the appropriate instruction manual and per applicable local and national codes. Connect all products to the proper electrical and pressure sources.
- To ensure proper performance, use qualified personnel to install, operate, update, program and maintain the product.
- When replacement parts are required, ensure that qualified people use replacement parts specified by Brooks Instrument. Unauthorized parts and procedures can affect the product's performance and place the safe operation of your process at risk. Look-alike substitutions may result in fire, electrical hazards or improper operation.
- Ensure that all equipment doors are closed and protective covers are in place, except when maintenance is being performed by qualified persons, to prevent electrical shock and personal injury.

TABLE OF CONTENTS

	Paragraph Number	Page Number
Section 1 INTRODUCTION		
General	1-1	1
Specifications	1-2	1
Section 2 RECEIPT OF EQUIPMENT		
General	2-1	1
Receipt of Equipment	2-2	1
Return Shipment	2-3	1
Section 3 INSTALLATION AND MAINTENANCE		
General	3-1	1
Cylinder Assembly Removal	3-2	1
Aggressive Products (AP) Cylinder Disassembly	3-3	2
Aggressive Products (AP) Cylinder Reassembly	3-4	2
Cup-Seal Replacement on Existing AP Option Piston	3-5	2
Section 4 MAINTENANCE		
General	4-1	3
Section 5 PARTS LIST		
General	5-1	3

LIST OF ILLUSTRATIONS

Figure Number	Title	Page Number
3-1	AP Option Assembly	2
5-1	Complete Assembly	6

LIST OF TABLES

Table Number	Title	Page Number
5-1	Complete Assembly Parts List	4 & 5

Section 1 INTRODUCTION

1-1 General

This manual contains specific instructions for receipt, installation and maintenance of Brooks® Control Valves containing the "AP" Cylinder Assembly. Also contained within is complete instructions for retrofitting existing standard valves with the "AP" Option package. This cylinder assembly is a direct replacement for existing units and requires no special parts or tools. It is designed for all Brooks 2, 3, 4 and 6", 150/300 lb. ANSI, Series 700 Valves. Spring loaded Teflon® cup-seals are utilized on the main body piston and low swell Nitrile O-rings in static positions.

1-2 Specifications

Materials of Construction

- Main Valve Cylinder: Ductile Iron, Nickel Coated
- Main Valve Piston: Bronze (Standard), Stainless Steel (Optional)
- Cup-Seals: Teflon
- O-rings: Nitrile (Static)
- Other Internal Parts: Stainless Steel

Ratings

WARNING: Do not exceed the ratings given below. Failure to heed this warning may result in serious personal injury and/or damage to the equipment.

- Maximum Safe Working Pressure
 - 150 lb. ANSI Steel Body: 285 psi (1965 kPa)
 - 300 lb. ANSI Steel Body: 740 psi (5102 kPa)
- Maximum Safe Working Temperature:
 - Standard: 150°F (65°C)
 - Optional: 250°F (121°C)

Section 2 RECEIPT OF EQUIPMENT

2-1 General

This section contains specific instructions for receipt of the Aggressive Products Cylinder Assembly.

2-2 Receipt of Equipment

When the equipment is received, the outside of the packing case should be checked for any damage incurred during shipment. If the packing case is damaged, the local carrier should be notified at once concerning his liability.

A report should be submitted to the Product Service Department, Brooks Instrument, P.O. Box 450, Statesboro, Georgia, 30459.

Remove the envelope containing the packing list. Carefully remove the equipment from the packing case. Make sure spare or replacement parts are not discarded with the packing material. Inspect for damaged or missing parts.

Refer to your packing list for information as to what is

supplied with your particular Valve or valve order. In the event that any items are missing from your shipment, contact your local Brooks representative or Sales Office. The serial number of your valve and sales order number should be supplied at this time.

2-3 Return Shipment

To be able to process return goods quickly and efficiently, it is IMPORTANT that you provide essential information. Do not return any assembly or part without an "R.M.R." (Returned Materials Report), or a letter which describes the problem, correction action, if any, to be taken, and the work that is to be performed at the factory. R.M.R. forms can be obtained from Brooks Sales Offices or the Service Department, Brooks Instrument, P.O. Box 450, Highway 301 N., Statesboro, Georgia, 30459.

Place a copy of either of the above inside the shipping container and attach it physically to the material being returned. A copy of your packing list should be placed inside an envelope and attached to the outside of the shipping container, or placed inside the container.

Section 3 INSTALLATION AND MAINTENANCE

3-1 General

The following information is intended as a guide for the general replacement and maintenance of the Brooks "AP" Cylinder Assembly.

CAUTION: Disassembly of this cylinder assembly is different than previous Brooks Control Valves and requires strict adherence to the procedures outlined in this manual. Failure to read and comply with these procedures could cause damage to the equipment and compromise the integrity of operation.

Read the entire recommended procedure for all installation operations and maintenance procedures before attempting to install or disassemble the valve.

3-2 Cylinder Assembly Removal - All Brooks Valves

1. Isolate the Control Valve from the system and bleed off pressure.
2. Loosen and remove the tubing from the cylinder head.
3. Remove the nuts securing the cylinder assembly within the valve body.
4. Tighten the two jack screws provided in the cylinder head until the cylinder assembly has been freed from the valve body. These screws should be tightened evenly to prevent damage to the cylinder O-ring and binding the cylinder assembly.
5. Remove the cylinder assembly from the valve body by pulling upward and evenly using both hands (on smaller valves) or a mechanical device (for larger models).

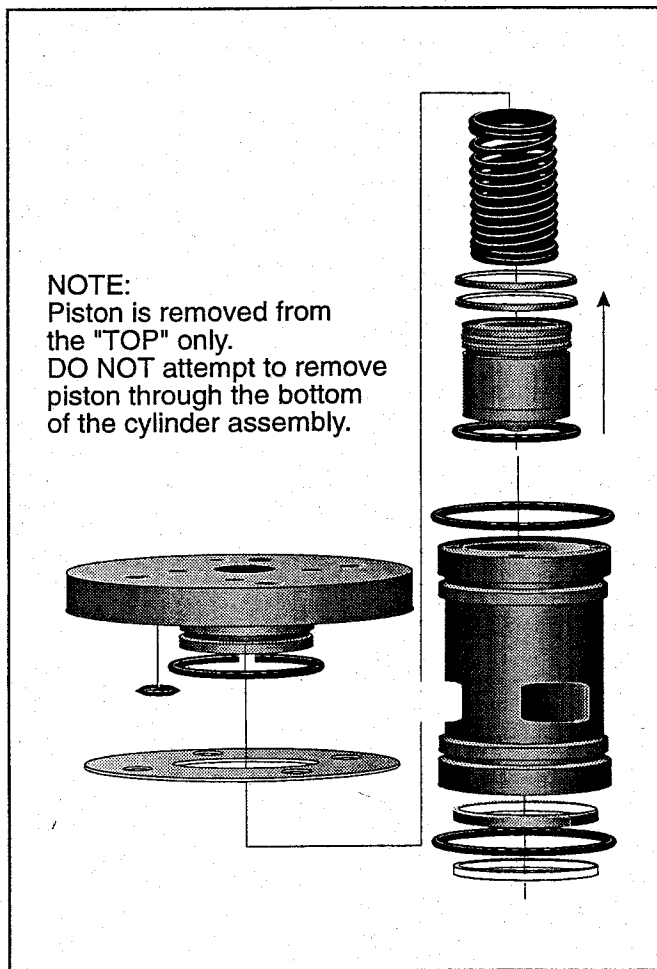

Figure 3-1 AP Option Assembly

3-3 Aggressive Products (AP) Cylinder Disassembly - Sizes 2-6" (Reference Table 5-1 Parts List)

WARNING: The Cylinder Head is bolted to a spring loaded cylinder assembly and will require caution when performing any disassembly procedure. Failure to comply with recommended practice could result in serious personal injury and/or damage to the equipment. Service should be performed only by trained and qualified service personnel.

1. Position the cylinder assembly with the Cylinder Head (item 5) up. Larger units may require the use of a spindle or arbor press to facilitate removal of the piston assembly in which case the arbor should be resting against the cylinder head.
2. Carefully loosen the socket-head Screws (item 6) which hold the cylinder head in place. Alternate to opposite sides to equalize release of spring tension on the Cylinder Head.
3. Using **EXTREME CAUTION** hold the Cylinder Head firmly against the cylinder assembly and remove the retaining Screws, Washer and Stat-O-Seal.
4. Lift off the Cylinder Head and Gasket and retain accompanying O-rings for reassembly. If an Indicator is

being used, care should be taken to avoid bending or damaging the Indicator Stem in this operation. Note: It is not necessary to remove the Indicator Guard (item 17) or other component parts of the Indicator at this time; however the indicator stem should be wiped clean of any residue or foreign material that may have gathered on its surface. This will protect the internal Cup Seal (item 21) from unnecessary abrasion upon removal of the Indicator Stem (item 27).

5. The Spring, Piston, Indicator Stem Assembly (if used) and Cylinder may be removed at this time by pushing from the bottom of the unit. See Figure 3-1.
NOTE: Do not attempt to remove the piston through the seat area. Removal through the seat area will destroy the spring loaded Teflon cup seals.
6. Inspect all O-rings (Cylinder, Piston, Cylinder Head and Indicator), and Cup-Seals for nicks, damage or wear and replace as required.
7. The cylinder and piston may be cleaned to remove foreign materials or residue that may impede proper operation. Care should be taken not to damage the piston seat radius or seals.

3-4 Aggressive Products (AP) Cylinder Reassembly

1. The Cup-Seals should be protected at all times against damage or distortion of any kind.
2. Proper installation dictates that Cup-Seals be installed with the closed ends facing "in".
3. To best accommodate Cup-Seal installation:
 - a. Place the inside edge of the bottom seal in the deep recess of the piston body (below the seal's resting position) and carefully pull into position. Adjust Cup-Seal position in its proper location.
 - b. Install the top Cup-Seal assuring that closed ends face "in".

3-5 Cup-Seal Replacement on existing "AP" Option Piston

A. General

If your Brook's Valve is being modified to accommodate applications requiring the use of aggressive products used in petroleum blending operations the following procedures should be followed in retrofitting your valve.

B. Retrofit

1. To replace existing standard cylinder assemblies with the current Brooks "AP" Option:
 - a. Remove the original cylinder assembly as shown in Section 3-2. The Cylinder Assembly will be supplied from the factory with or without an indicator (specified on order).
 - b. Clean and inspect O-ring Sealing Surfaces in the main valve body. Apply a lightweight lubricant to these surfaces before installing the new cylinder assembly.
 - c. Lower the "New" Cylinder Assembly and Cylinder Head into the valve body. Align the bolt holes in

the Cylinder Head with the studs in the main Valve Body.

- d. Fasten the Cylinder Head into position using retaining nuts. Tighten nuts, alternating to opposite sides, to assure a uniform seat.
 - e. Return all tubing and/or valve accessories to their original position.
2. To upgrade existing valves having the original "AP" option (received prior to September 1992) the following parts have been supplied as a separate kit. (Reference Figure 5-1 for complete valve part numbers).

- Washers (Item 29)
- Stat-O-Seals (Item 30)
- 1 Gasket (Item 31)
- 3 O-rings (Replaces existing O-rings, items 3 and 4 of the same part numbers.)

To upgrade existing "AP" units supplied prior to September, 1992:

- a. Follow procedures described in Section 3-2 for general disassembly and Section 3-3 for Aggressive Products Cylinder disassembly.
- b. Replace O-rings and install Gasket, Stat-O-Seal and Washers as required (reference Figure 5-1).
- c. Complete Cylinder assembly by installing Piston and all component parts through the top of the Cylinder Housing.

NOTE: Do not attempt to install the piston through the seat area. Attempts to assemble through the seat area will destroy the spring loaded teflon cup-seals.

- d. Secure Cylinder Assembly to Cylinder Head using hand pressure or arbor press for ease of installation.

CAUTION: The Cylinder Head is to be bolted to a spring loaded cylinder assembly and will require caution when performing assembly procedure.

- d. Lower the "New" Cylinder Assembly and Cylinder Head into the valve body. Align the bolt holes in the Cylinder Head with the studs in the main Valve Body.
- e. Fasten the Cylinder Head into position using retaining nuts. Tighten nuts, alternating to opposite sides, to assure a uniform seat.
- f. Return all tubing and/or valve accessories to their original position.

Section 4 TROUBLESHOOTING AND PREVENTIVE MAINTENANCE

4-1 General

The most frequent problem encountered with any con-

trol valve is the accumulation of sediment, rouge, scale and other foreign material in the pilot or its supply system. It is therefore good practice to periodically remove the pilot from the valve and inspect it for accumulation of these materials.

The strainer and needle valve in the pilot supply line should also be flushed periodically to avoid erratic control and slow response typical to obstructed flow. If substandard conditions persist after thoroughly cleaning the system, examine the pilot for swollen O-rings.

Periodic examination of all Seals and O-rings for nicks, cuts and wear is recommended, reference Section 3, Maintenance, for disassembly/assembly instructions.

Section 5 PARTS LIST

5-1 General

This section contains the necessary parts required to assemble any standard unit that is covered in this bulletin. Recommended spare parts have been indicated using an asterisk before the item number. All part numbers shown reflect standard materials of construction. For other materials of construction, special requirements or part numbers not listed, consult factory.

TRADEMARKS

Brooks Brooks Instrument Division, Emerson Electric Co.
Kalrez E.I. DuPont de Nemours & Co.
Teflon E.I. DuPont de Nemours & Co.

Table 5-1 Parts List

Item	Qty. Req.	Description	Size
			2"
1	1	Cylinder	520021-500
2	1	Cap Plug	154774
*3	2	O-ring (Nitrile)	157000-120
*4	1	O-ring (Nitrile)	157029-120
5	1	Cylinder Head	520056-510
6		A/R Screw	151012 (4)
7	1	Spring (Medium)	520029
		(Light)	520031
		(Heavy)	520059
*8	2	Cup-Seal (Teflon)	159775
*9	1	O-ring (Nitrile)	152085-120
10	1	Lock Ring	156460
11	1	Sealing Ring	520026-500
12	1	Piston	520057-230
13	1	Screw	151069
*14	1	O-ring (Nitrile)	152070-120
15	1	Piston Plug	----
16	1	Pin	153540
17	1	Indicator Guard	540082-400
18	2	Washer	152119
19	2	Screw	150727
*20	1	O-ring (Nitrile)	157012-120
*21	1	Cup Seal	159777
22	2	Washer	151979-419
23	1	Upper Bearing Gland	520189-500
24	1	Seal Retainer	540188-500
25	1	Rulon Bearing	155150-001
26	1	Indicator Guard Adapter	540081-500
27	1	Indicator Stem	520183
*28		A/R O-ring (Nitrile)	----
		Old Style Bodies Only	
29	6	Washer	151901 (4)
*30	6	Stat-O-Seal	152028
*31	1	Gasket	159071
32	1	Adaptor Ind. Stem	540086
33	1	Piston Connector	540087
34	1	Hex Nut	151544-019
35	1	Flat Washer	151857
36	1	Lock Washer	152119
37	1	Seal Ring	520026-201
38	1	Retaining Ring	156575
39	1	O-ring	159578-120
40	1	Retaining Ring	156576

*Recommended Spare Parts

Table 5-1 Parts List Continued

Item	Qty. Req.	Description	Size		
			3"	4"	6"
1	1	Cylinder (Ported)	530471-500	540471-500	560471-500
2	1	Cap Plug	154774	154774	154774
*3	2	O-ring (Nitrile)	152095-120	152094-120	152079-120
*4	1	O-ring (Nitrile)	159575-120	157032-120	159576-120
5	1	Cylinder Head	530056-510	540056-510	560056-510
6		A/R Screw	151012 (6)	151012 (6)	151012 (8)
7	1	Spring (Medium)	530029	540029	560029
		(Light)	530031	540031	560031
		(Heavy)	530059	540059	560059
*8	2	Cup-Seal (Teflon)	159714	159715	159716
*9	1	O-ring (Nitrile)	152100-120	152080-120	157003-120
10	1	Lock Ring	156458	156459	156461
11	1	Sealing Ring	530026-500	540026-500	560026-500
12	1	Piston	530026-230	540057-230	560057-230
		Piston w/ Indicator	530057-231	540057-231	560057-231
13	3	Screw	150333	150333	150333
*14	1	O-ring (Nitrile)	152048-120	152048-120	152048-120
15	1	Piston Plug	540053	540053	540053
16	1	Pin	153622	153622	153622
17	1	Indicator Guard	540082-400	540082-400	540082-400
		6" Two Stage			580082-400
18	2	Washer	152119	152119	152119
19	2	Screw	150727	150727	150727
*20	1	O-ring (Nitrile)	157012-120	157012-120	157012-120
*21	1	Cup Seal (Teflon)	159777	159777	159777
22	1	Washer	151979-419	151979-419	151979-419
23	1	Upper Bearing Gland	520189-500	520189-500	520189-500
24	1	Seal Retainer	540188-500	540188-500	540188-500
25	1	Rulon Bearing	155150-001	155150-001	155150-001
26	1	Indicator Guard	540081-500	540081-500	540081-500
		Adaptor			
27	1	Indicator Stem	530183	540183	560183
		6" Two-Stage			560183-001
*28		A/R O-ring (Nitrile)	152086-120	152070-120	152070-120
		Old Style Bodies Only			
29		A/R Washer	151901 (6)	151901 (6)	151901 (6)
*30		A/R Stat-O-Seal	152028 (6)	152028 (6)	152028 (6)
*31	1	Gasket	159070	159068	159069
32	1	Instruction Plate	520020	520020	520020

*Recommended Spare Parts

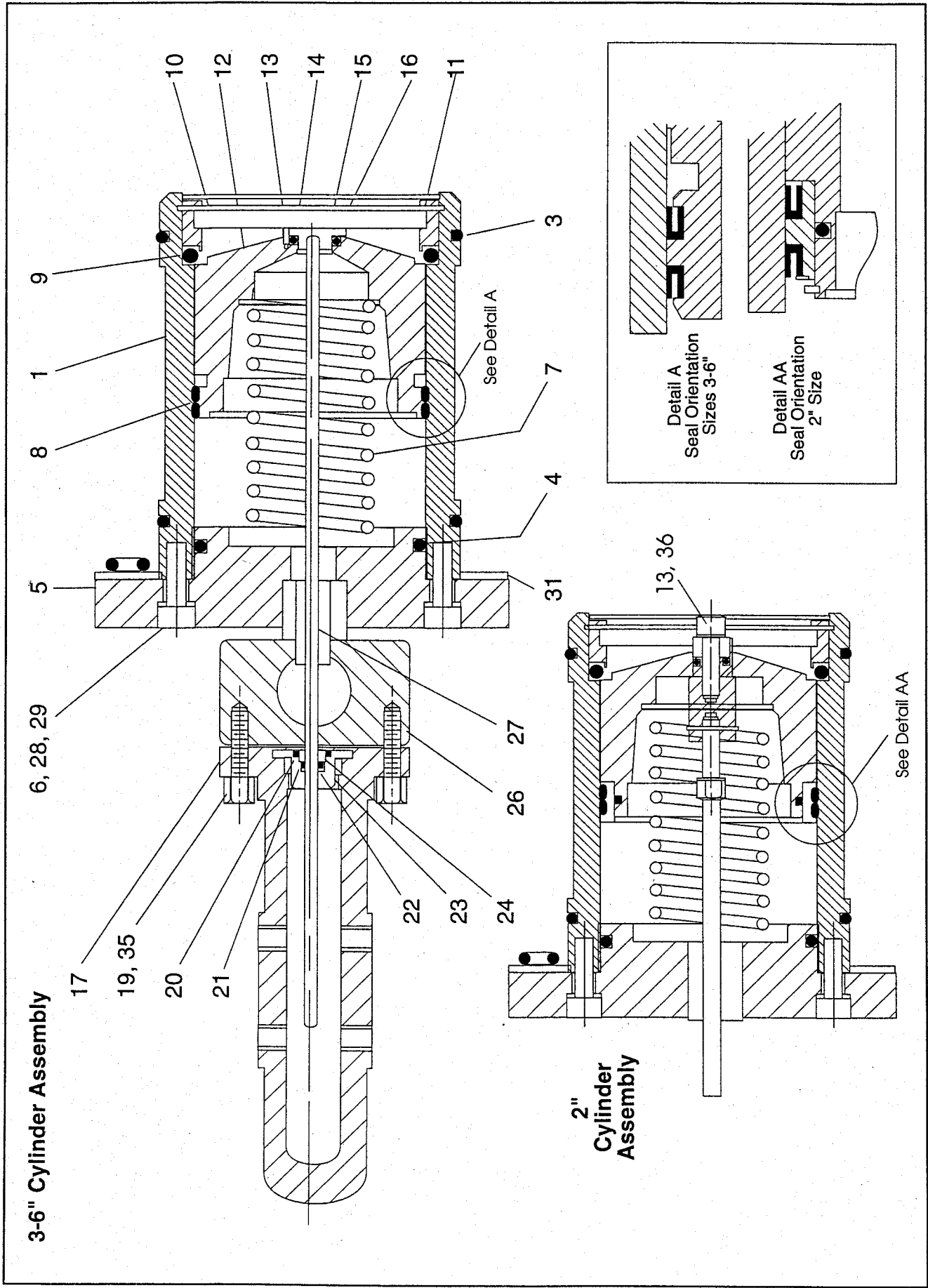

Figure 5-1 Valve Cylinder Assembly

GUARANTEE

If at any time, within one year after shipment but not thereafter, it is proved that any part of the equipment furnished by us was defective when shipped by us, we will repair or replace the same free of charge F.O.B. our plant. Notice of this claim must be made to us within one year after delivery. Our liability is limited to replacement of such defective parts or equipment. There are no guarantees or warranty expressed or implied other than those herein specifically mentioned.

Brooks Instrument shall not, in any event, be liable for any consequential damages, secondary charges, expenses for erection or disconnecting or losses resulting from any alleged defect in the apparatus.

It is understood that corrosion or erosion of material is not covered by our guarantee.

Brooks Instrument
Highway 301 North
P.O. Box 450
Statesboro, GA 30459-0450 USA
Tel (912) 764-5471
Fax (912) 764-2538
Telex 160069

Brooks Instrument

FISHER-ROSEMOUNT