

TABLE 1 - FM ENTITY PARAMETERS

Input Parameter	
$U_i$ (Vmax) = 30 Vdc	Vt or Voc of loop must be $\leq 30$ Vdc
$I_i$ (Imax) = 200 mA	It or Isc of loop must be $\leq 200$ mA
$P_i$ (Pmax) = 1 W	
$C_i$ = 0 $\mu$ F	Device does not add capacitance to the loop
$L_i$ = 0 mH	Device does not add inductance to the loop

Output Parameter	
$U_o$ (Voc) = 1.9 Vdc	
$I_o$ (Isc) = 32 $\mu$ A	
$P_o$ = 61 $\mu$ W	
$C_a$ = 100 $\mu$ F	
$L_a$ = 5600 mH	

Classification: T4

Max. Ambient temp:  
-10°C less than or equal to  $T_a$   
less than or equal to +50°C

WARNING - BATTERIES MUST BE CHARGED  
IN A NONHAZARDOUS LOCATIONS ONLY

WARNING - SUBSTITUTION OF COMPONENTS  
MAY IMPAIR INTRINSIC SAFETY

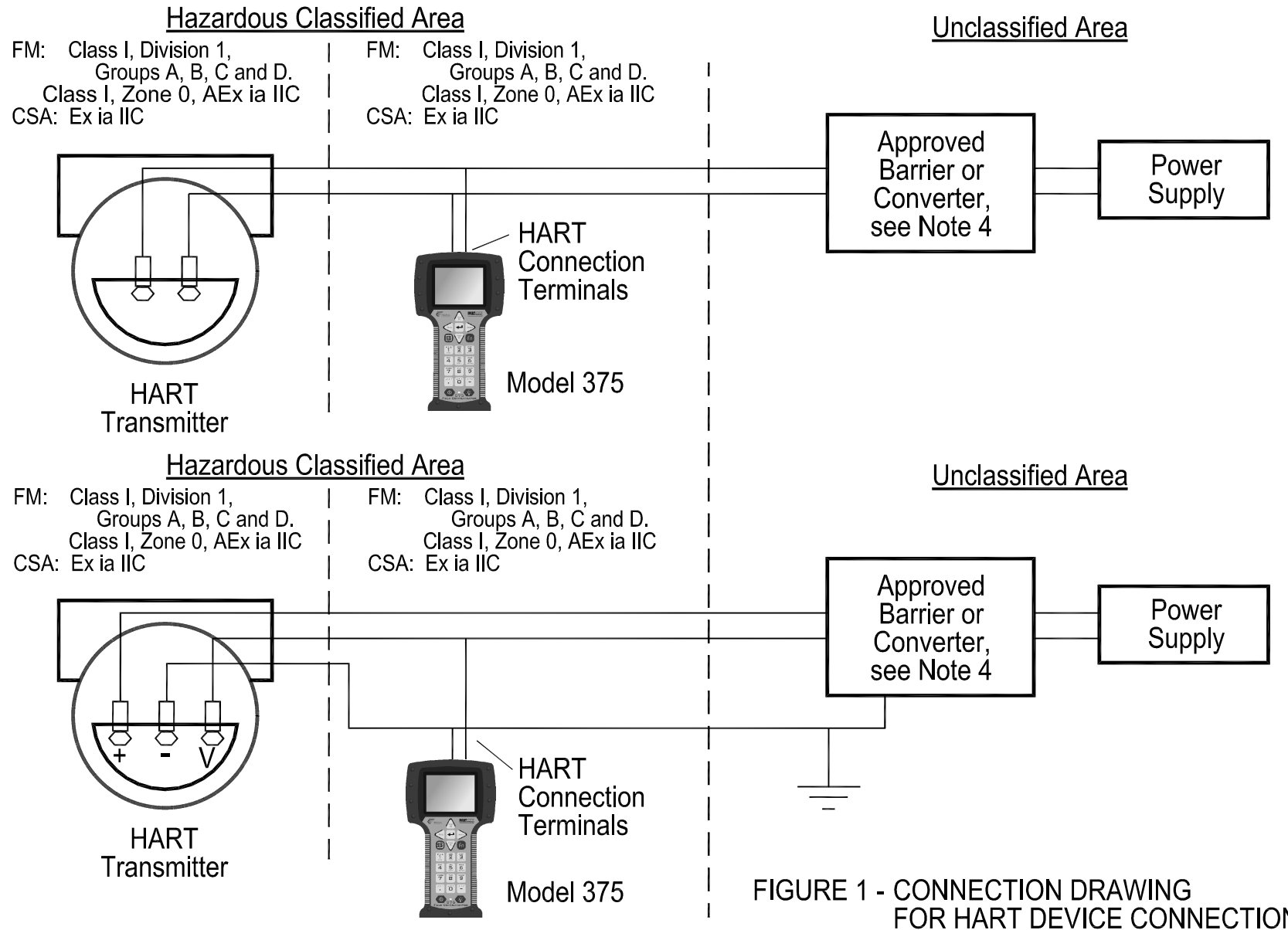

FIGURE 1 - CONNECTION DRAWING  
FOR HART DEVICE CONNECTION

Notes:

- No revision to this drawing without prior FM Approval and CSA International Approval.
- Associated Apparatus manufacturer's installation drawing must be followed when installing the equipment.
- Associated Apparatus and Model 375 Communicator must meet the following parameters :
  - $U_o$ , Voc or Vt of the barrier plus Voc of the Model 375 Communicator must be less than or equal to  $U_i$  (Vmax)
  - $I_o$ , Isc or It of the barrier plus Isc of the Model 375 Communicator must be less than or equal to  $I_i$  (Imax)
  - $P_o$  of the barrier plus  $P_o$  of the Model 375 Communicator must be less than or equal to  $P_i$  (Pmax)
  - $C_a$  of barrier must be greater than or equal to  $C_i$  of the Model 375 Communicator plus  $C_i$  of the HART Transmitter plus  $C_{cable}$
  - $L_a$  of barrier must be greater than or equal to  $L_i$  of the Model 375 Communicator plus  $L_i$  of the HART Transmitter plus  $L_{cable}$
  - $L_a$  of Model 375 Communicator must be greater than or equal to  $L_i$  of the HART Transmitter plus  $L_{cable}$
  - $C_a$  of Model 375 Communicator must be greater than or equal to  $C_i$  of the HART Transmitter plus  $C_{cable}$

FM:

- The Associated Apparatus must be FM Approved.
- HART Transmitter must be FM Approved for use with the Model 375 Communicator.
- Installation should be in accordance with ANSI/ISA RP12.06.01 "Installation of Intrinsically safe systems for Hazardous (classified) Locations" and the National Electrical Code (ANSI/NFPA 70).
- Control equipment connected to Associated Apparatus must not use or generate more than 250V.
- Resistance between Intrinsically Safe Ground and Earth Ground must be less than 1.0 Ohm.

CSA:

- The Associated Apparatus must be CSA certified.
- HART Transmitter must be CSA certified for use with the Model 375 Communicator.
- Installation should be in accordance with Canadian Electrical Code, CSA 22.1, Part 1.
- Control equipment connected to Associated Apparatus must not use or generate more than 250V.
- Resistance between Intrinsically Safe Ground and Earth Ground must be less than 1.0 Ohm.

UNLESS OTHERWISE SPECIFIED  
TOLERANCES  
.X± \_\_\_\_\_  $\angle$  ± \_\_\_\_\_  
.XX± \_\_\_\_\_  
.XXX± \_\_\_\_\_  
R OR CHAM \_\_\_\_\_  
UNIT OF MEASURE \_\_\_\_\_  
DO NOT SCALE THIS DWG  
ANSI Y14.5M

© 2004 Fisher-Rosemount Systems, Inc. All Rights Reserved  
Emerson Process Management  
Distribution Ltd  
Leicester, UK

REVISIONS	BY	DATE	DESIGN
B	EJH	30SEP04	20417

MODEL 375  
IS INSTALLATION DRAWING

DWN.	BY	DATE	DESIGN	REV
	EJH	24AUG04		B
	MJH	24AUG04		
	VRM	24AUG04		

SCALE NONE TOOL A SIZE C  
DWG. NO. 00375-1130  
SHEET 1 OF 4

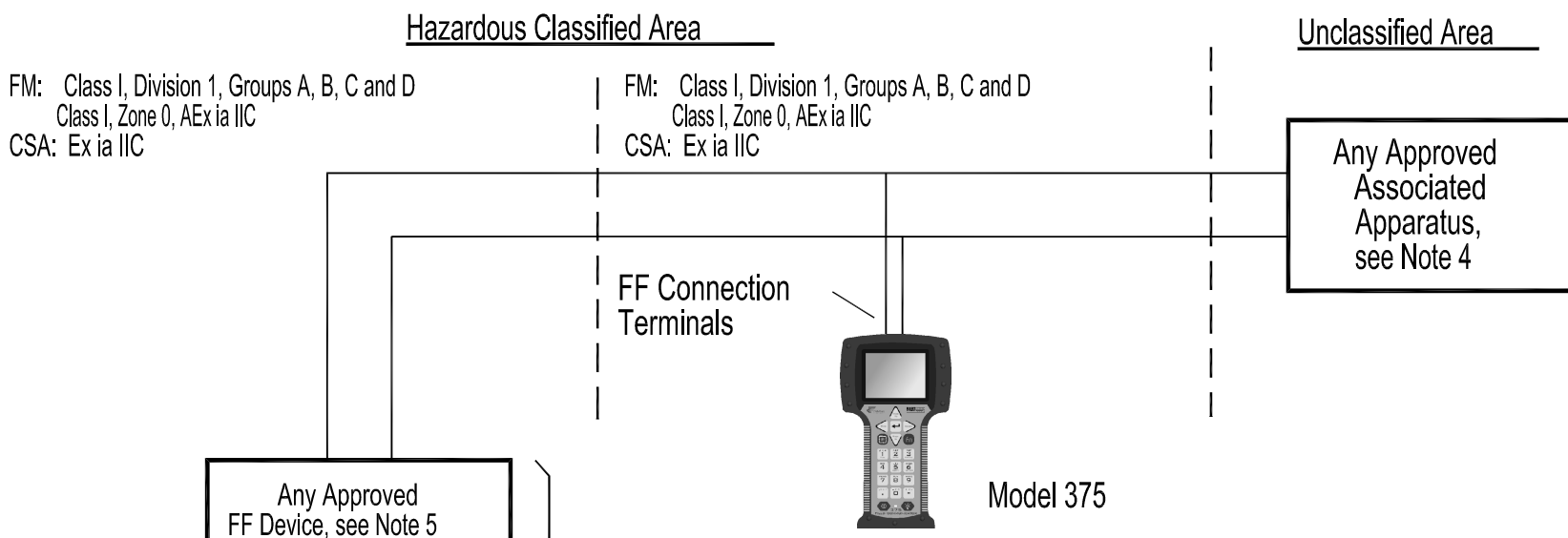

**WARNING - BATTERIES MUST BE CHARGED  
IN A NONHAZARDOUS LOCATIONS ONLY**

**WARNING - SUBSTITUTION OF COMPONENTS  
MAY IMPAIR INTRINSIC SAFETY**

Notes:

1. No revision to this drawing without prior FM Approval and CSA International Approval.
2. Associated Apparatus manufacturer's installation drawing must be followed when installing the equipment.
3. Associated Apparatus and Model 375 Communicator must meet the following parameters :
  - a)  $U_o$ ,  $V_{oc}$  or  $V_t$  of the barrier plus  $V_{oc}$  of the Model 375 Communicator must be less than or equal to  $U_i$  ( $V_{max}$ )
  - b)  $I_o$ ,  $I_{sc}$  or  $I_t$  of the barrier plus  $I_{sc}$  of the Model 375 Communicator must be less than or equal to  $I_i$  ( $I_{max}$ )
  - c)  $P_o$  of the barrier plus  $P_o$  of the Model 375 Communicator must be less than or equal to  $P_i$  ( $P_{max}$ )
  - d)  $C_a$  of barrier must be greater than or equal to  $C_i$  of the Model 375 Communicator plus  $C_i$  of the HART Transmitter plus  $C_{cable}$
  - e)  $L_a$  of barrier must be greater than or equal to  $L_i$  of the Model 375 Communicator plus  $L_i$  of the HART Transmitter plus  $L_{cable}$
  - f)  $L_a$  of Model 375 Communicator must be greater than or equal to  $L_i$  of the HART Transmitter plus  $L_{cable}$
  - g)  $C_a$  of Model 375 Communicator must be greater than or equal to  $C_i$  of the HART Transmitter plus  $C_{cable}$

FM:

4. The Associated Apparatus must be FM Approved.
5. FF Device must be FM Approved for use with the Model 375 Communicator.
6. Installation should be in accordance with ANSI/ISA RP12.06.01 "Installation of Intrinsically safe systems for Hazardous (classified) Locations" and the National Electrical Code (ANSI/NFPA 70).
7. Control equipment connected to Associated Apparatus must not use or generate more than 250V.
8. Resistance between Intrinsically Safe Ground and Earth Ground must be less than 1.0 Ohm.

CSA:

4. The Associated Apparatus must be CSA certified.
5. FF Device must be CSA certified for use with the Model 375 Communicator.
6. Installation should be in accordance with Canadian Electrical Code, CSA 22.1, Part 1.
7. Control equipment connected to Associated Apparatus must not use or generate more than 250V.
8. Resistance between Intrinsically Safe Ground and Earth Ground must be less than 1.0 Ohm.

**For Non-FISCO installation**

$U_i$  ( $V_{max}$ ) = 30 Vdc  
 $I_i$  ( $I_{max}$ ) = 380 mA  
 $P_i$  ( $P_{max}$ ) = 1.3 W  
 $C_i$  = 0  $\mu$ F  
 $L_i$  = 0 mH  
  
 $U_o$  ( $V_{oc}$ ) = 1.9 Vdc  
 $I_o$  ( $I_{sc}$ ) = 32  $\mu$ A  
 $P_o$  = 61  $\mu$ W  
 $C_a$  = 100  $\mu$ F  
 $L_a$  = 5600 mH  
  
 Leakage current:  
 less than or equal to 50  $\mu$ A  
  
 Classification: T4  
  
 Max. Ambient temp:  
 -10°C less than or equal to  $T_a$   
 less than or equal to +50°C

Any Approved FF Device, see Note 5  
 Any Approved FF Device, see Note 5  
 Any Approved FF Device, see Note 5  
 Any Approved FF Device, see Note 5  
  
**MULTIPLE FF DEVICES**  
 ( Number is limited by the requirement to meet all other IS requirement for the network. )

**FIGURE 2 - CONNECTION DRAWING FOR FF Non-FISCO DEVICE CONNECTION**

UNLESS OTHERWISE SPECIFIED TOLERANCES .X± _____ / ± _____ .XX± _____ .XXX± _____		© 2004 Fisher-Rosemount Systems, Inc. All Rights Reserved		MODEL 375 IS INSTALLATION DRAWING	
R OR CHAM _____	UNIT OF MEASURE _____	Emerson Process Management Distribution Ltd Leicester, UK		BY: EJM	DATE: 24AUG04
DO NOT SCALE THIS DWG	ANSI Y14.5M	REVISIONS	APPROVED	DESIGN	DWG. NO.
		B EJM 30SEP04 20417	VRM	24AUG04	00375-1130
			SCALE: NONE	TOOL: A	SIZE: C
					SHEET 2 OF 4

Hazardous Classified Area

Unclassified Area

FM: Class I, Division 1, Groups A, B, C and D  
Class I, Zone 0, AEx ia IIC  
CSA: Ex ia IIC

FM: Class I, Division 1, Groups A, B, C and D  
Class I, Zone 0, AEx ia IIC  
CSA: Ex ia IIC

WARNING - BATTERIES MUST BE CHARGED  
IN A NONHAZARDOUS LOCATIONS ONLY

WARNING - SUBSTITUTION OF COMPONENTS  
MAY IMPAIR INTRINSIC SAFETY

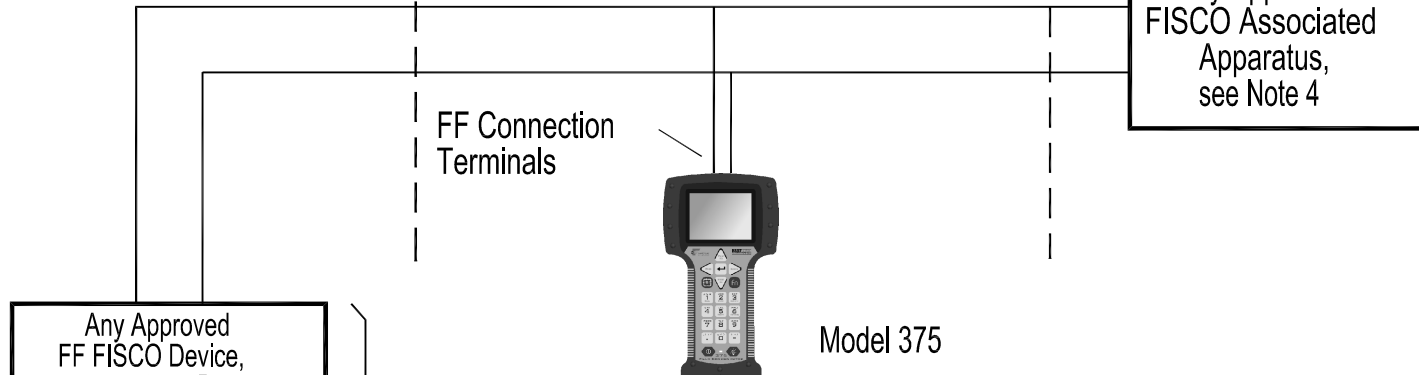

Model 375

MULTIPLE  
FF DEVICES  
( Number is  
limited by the  
requirement to  
meet all other  
IS and FISCO  
requirement  
for the network. )

For FISCO installation

$U_i (V_{max}) = 17.5 \text{ Vdc}$   
 $I_i (I_{max}) = 215 \text{ mA}$   
 $P_i (P_{max}) = 1.9 \text{ W}$   
 $C_i = 0 \text{ uF}$   
 $L_i = 0 \text{ mH}$   
 $U_o (V_{oc}) = 1.9 \text{ Vdc}$   
 $I_o (I_{sc}) = 32 \text{ uA}$   
 $P_o = 61 \text{ uW}$   
 $C_a = 100 \text{ uF}$   
 $L_a = 5600 \text{ mH}$   
 Leakage current:  
 less than or equal to 50 uA  
 Classification: T4  
 Max. Ambient temp:  
 -10°C less than or equal to  $T_a$   
 less than or equal to +50°C

Notes:

- No revision to this drawing without prior FM Approval and CSA International Approval.
- Associated Apparatus manufacturer's installation drawing must be followed when installing the equipment.
- Associated Apparatus and Model 375 Communicator must meet the conditions of the "FISCO CONCEPT" see notes on Page 4

FM:

- The Associated Apparatus must be FM Approved.
- FF Device must be FM Approved for use with the Model 375 Communicator.
- Installation should be in accordance with ANSI/ISA RP12.06.01 "Installation of Intrinsically safe systems for Hazardous (classified) Locations" and the National Electrical Code (ANSI/NFPA 70).
- Control equipment connected to Associated Apparatus must not use or generate more than 250V.
- Resistance between Intrinsically Safe Ground and Earth Ground must be less than 1.0 Ohm.

CSA:

- The Associated Apparatus must be CSA certified.
- FF Device must be CSA certified for use with the Model 375 Communicator.
- Installation should be in accordance with Canadian Electrical Code, CSA 22.1, Part 1.
- Control equipment connected to Associated Apparatus must not use or generate more than 250V.
- Resistance between Intrinsically Safe Ground and Earth Ground must be less than 1.0 Ohm.

FIGURE 3 - CONNECTION DRAWING  
FOR FF FISCO DEVICE  
CONNECTION

UNLESS OTHERWISE SPECIFIED TOLERANCES .X± _____ / ± _____ .XX± _____ .XXX± _____ R OR CHAM _____ UNIT OF MEASURE _____ DO NOT SCALE THIS DWG ANSI Y14.5M		© 2004 Fisher-Rosemount Systems, Inc. All Rights Reserved		MODEL 375 IS INSTALLATION DRAWING	
Emerson Process Management Distribution Ltd Leicester, UK		BY: EJM DATE: 24AUG04	DESIGN		
REVISIONS B EJM 30SEP04 20417		CHKD: MJM DATE: 24AUG04	DWG. NO.		REV B
SUPERSEDES		APVD: VRM DATE: 24AUG04	00375-1130		
		SCALE: NONE	TOOL: A	SIZE: C	SHEET 3 OF 4

## FISCO CONCEPT

THE FISCO CONCEPT ALLOWS INTERCONNECTION OF INTRINSICALLY SAFE APPARATUS TO ASSOCIATED APPARATUS NOT SPECIALLY EXAMINED IN SUCH COMBINATION. THE CRITERIA FOR INTERCONNECTION IS THAT THE VOLTAGE ( $U_i$  OR  $V_{max}$ ), THE CURRENT ( $I_i$  OR  $I_{max}$ ) AND THE POWER ( $P_i$  OR  $P_{max}$ ) WHICH AN INTRINSICALLY SAFE APPARATUS CAN RECEIVE AND REMAIN INTRINSICALLY SAFE CONSIDERING FAULTS, MUST BE EQUAL OR GREATER THAN VOLTAGE ( $U_o$ ,  $V_{oc}$  OR  $V_t$ ), THE CURRENT ( $I_o$ ,  $I_{sc}$  OR  $I_t$ ) AND THE POWER ( $P_o$  OR  $P_{max}$ ) LEVELS WHICH CAN BE DELIVERED BY THE ASSOCIATED APPARATUS, CONSIDERING FAULTS AND APPLICABLE FACTORS. IN ADDITION, THE MAXIMUM UNPROTECTED CAPACITANCE ( $C_i$ ) AND THE INDUCTANCE ( $L_i$ ) OF EACH APPARATUS (OTHER THAN THE TERMINATION) CONNECTED TO THE FIELDBUS MUST BE LESS THAN OR EQUAL TO 5 nF and 10 uH RESPECTIVELY.

IN EACH SEGMENT ONLY ONE ACTIVE DEVICE, NORMALLY THE ASSOCIATED APPARATUS, IS ALLOWED TO PROVIDE THE NECESSARY ENERGY FOR THE FIELDBUS SYSTEM. THE VOLTAGE  $U_o$  (OR  $V_{oc}$  OR  $V_t$ ) OF THE ASSOCIATED APPARATUS IS LIMITED TO A RANGE OF 14 V TO 24 Vdc ALL OTHER EQUIPMENT CONNECTED TO THE BUS CABLE HAS TO BE PASSIVE, MEANING THAT THEY ARE NOT ALLOWED TO PROVIDE ENERGY TO THE SYSTEM, EXCEPT A LEAKAGE CURRENT OF 50uA FOR EACH CONNECTED DEVICE. SEPARATELY POWERED EQUIPMENT NEEDS GALVANIC ISOLATION TO ASSURE THAT THE INTRINSICALLY SAFE FIELDBUS CIRCUIT REMAINS PASSIVE.

THE CABLE USED TO INTERCONNECT DEVICES NEEDS TO HAVE THE PARAMETERS IN THE FOLLOWING RANGE:

- Loop Resistance R: 15.....150 Ohm/km
- Inductance per unit length L: 0.4.....1 mH/km
- Capacitance per unit length C: 80.....200 nF
- C = C line/line + 0.5C line/screen, if both lines are floating, or
- C = C line/line + C line/screen, if the screen is connected to one line
- Length of trunk cable: less than or equal to 1000m
- Length of spur cable: less than or equal to 30m
- Length of spur splice: less than or equal to 1m

AT EACH END OF THE TRUNK CABLE AN APPROVED INFALLIBLE LINE TERMINATION WITH THE FOLLOWING PARAMETERS IS SUITABLE:

- R = 90.....100 Ohm
- C = 0.....2.2 uF

ONE OF THE ALLOWED TERMINATIONS MIGHT ALREADY BE INTEGRATED IN THE ASSOCIATED APPARATUS. THE NUMBER OF PASSIVE APPARATUS CONNECTED TO THE BUS SEGMENT IS NOT LIMITED DUE TO I.S. REASONS. IF THE ABOVE RULES ARE RESPECTED, UP TO A TOTAL LENGTH OF 1000 m (SUM OF TRUNK AND ALL SPUR CABLES) OF CABLE IS PERMITTED. THE INDUCTANCE AND THE CAPACITANCE OF THE CABLE WILL NOT IMPAIR THE INTRINSIC SAFETY OF THE INSTALLATION.

<p>UNLESS OTHERWISE SPECIFIED TOLERANCES</p> <p>.X± _____ <math>\angle</math> ± _____</p> <p>.XX± _____</p> <p>.XXX± _____</p> <p>R OR CHAM _____</p> <p>UNIT OF MEASURE _____</p> <p>DO NOT SCALE THIS DWG</p> <p> ANSI Y14.5M</p>	<p>© 2004 Fisher-Rosemount Systems, Inc. All Rights Reserved</p> <p>Emerson Process Management Distribution Ltd Leicester, UK</p>	<p>MODEL 375 IS INSTALLATION DRAWING</p> <table border="1" style="width: 100%; border-collapse: collapse;"> <tr> <td style="width: 10%;"></td> <td style="width: 10%;">BY</td> <td style="width: 10%;">DATE</td> <td style="width: 10%;">DESIGN</td> <td style="width: 10%;"></td> <td style="width: 10%;"></td> </tr> <tr> <td>DWN.</td> <td>EJH</td> <td>24AUG04</td> <td></td> <td></td> <td></td> </tr> <tr> <td>CHKD.</td> <td>MJH</td> <td>24AUG04</td> <td></td> <td>DWG. NO.</td> <td></td> </tr> <tr> <td>APVD.</td> <td>VRM</td> <td>24AUG04</td> <td></td> <td>00375-1130</td> <td>REV B</td> </tr> <tr> <td>SCALE</td> <td>NONE</td> <td>TOOL</td> <td>A</td> <td>SIZE</td> <td>C</td> </tr> </table> <p style="text-align: right;">SHEET 4 OF 4</p>		BY	DATE	DESIGN			DWN.	EJH	24AUG04				CHKD.	MJH	24AUG04		DWG. NO.		APVD.	VRM	24AUG04		00375-1130	REV B	SCALE	NONE	TOOL	A	SIZE	C
	BY	DATE	DESIGN																													
DWN.	EJH	24AUG04																														
CHKD.	MJH	24AUG04		DWG. NO.																												
APVD.	VRM	24AUG04		00375-1130	REV B																											
SCALE	NONE	TOOL	A	SIZE	C																											