

# CSI 2130 Machinery Health Analyzer

- Data collection, vibration analysis, alignment and balancing in a single unit
- Embedded intelligence unlocks powerful technology solutions
- Compact, rugged design holds up to any plant environment
- Intuitive operation shortens the learning curve for faster implementation
- Modular format allows you to add capabilities as your needs change
- Upload data to AMS Suite for a single view of machinery health



*The Route application in the CSI 2130 uses pre-defined settings to provide instant feedback about machinery health in an easy-to-read color bar graph.*

## Overview

Maintenance departments today are asked to run with fewer staff and smaller budgets than ever before. In this do-more-with-less environment, maintenance personnel can't afford to continuously chase the next breakdown. They need to quickly and accurately identify developing faults and find the root cause of the machinery problem so that it can be fixed.

An effective technology solution must be simple to operate – reducing training requirements – while providing fast, actionable information to help you prioritize maintenance activities. Emerson's CSI 2130 Machinery Health Analyzer was developed with these requirements in mind.

The CSI 2130 stands alone as the industry-leading vibration data collector. In addition, the CSI 2130 can provide:

- Advanced vibration analysis
- Cross-channel analysis
- Transient analysis
- Dynamic balancing
- Laser shaft alignment
- Motor monitoring



Complex data from vibration signals is condensed into machinery health information and presented in an easy-to-understand bar graph format. Details are available at the push of a button.

Routine data and corrective maintenance jobs can be uploaded to AMS Suite: Machinery Health Manager for analysis and reporting. AMS Machinery Manager integrates data from multiple technologies, including vibration and oil analysis, thermography, and alignment and balancing into a single database. Alerts generated by AMS Machinery Manager can be exported automatically to AMS Suite: Asset Performance Management where they are combined with alerts from other plant assets to provide a unified view of your plant's health. These predictive diagnostics power PlantWeb® by enabling plant personnel to improve plant availability and reliability.

## Monitor More Machines in Less Time

As shown below, data collection time is reduced by as much as 60% compared to the CSI 2120, and even more when compared to other instruments. Faster data collection translates into more machines monitored and more time dedicated to machinery analysis.

## Portable and Durable

The durability of this unit makes it ideal for field work in a wide variety of industrial applications.

- Large Color Display: backlit VGA display for use anywhere.
- Small and Lightweight: easily carried on long routes
- In-Field Reports: color-coded alarm report for each point.
- Industrial Design: IP 65 rated with optional safety rating.

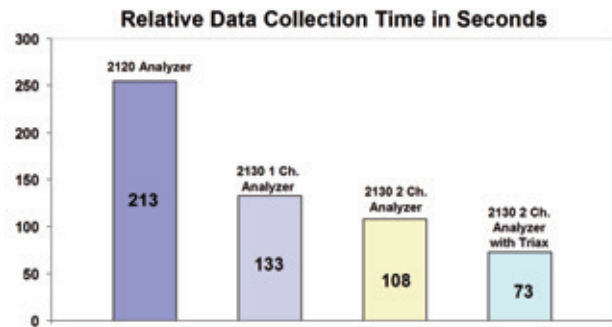

## Increase Productivity with the Dual-Channel Option

The CSI 2130 is available with either one or two channels for vibration analysis. The dual-channel option not only enables advanced analysis options, but also brings significant efficiency improvements. Emerson's patented dual-channel data collection technique slashes measurement time by an additional 20% to 45%. This increase in productivity translates into a complete return on investment within the first year.

## Easy Operation

The CSI 2130 requires only minimal training for effective operation. In addition to collecting data, the CSI 2130 converts data into actionable information about machinery health. For example, it can automatically distinguish between an imbalance and a bearing fault. The user is instantly notified about the nature of developing faults at the time of measurement, so that you can focus your attention on critical machine issues immediately.

## Embedded Intelligence

The ability to perform additional diagnostic tests at the machine site transforms simple data collection into an effective machinery health program. In today's demanding work environment, it is difficult to find the time to acquire advanced analysis skills. Embedded diagnostics enable even a novice user to conduct sophisticated tests with the touch of a button. The bottom line impact is that users can quickly harness the full power of the CSI 2130 in the field, immediately impacting your bottom line.

## Detect the Earliest Sign of Bearing and Gear Wear

Detecting imbalance or misalignment is simple with most data collectors, but the CSI 2130 can also detect developing faults on bearings and gears.

Emerson's patented PeakVue® processing applies digital technology to detect stress waves – the earliest sign of bearing and gear wear. Demodulation and other analog technologies typically can not detect such faults until much later – after the machine is already damaged.

PeakVue processing not only offers the earliest warning of developing faults, it also provides an indication of severity. Measurements can be translated into reliable trends to determine the optimal timing for maintenance.

With PeakVue, machinery faults are clearly visible in the waveform, opening up new options for fault detection and diagnosis.

## Full Spectrum of Measurement

Another unique feature of the CSI 2130 is its exceptional frequency range. Using Emerson's patented Slow Speed Technology (SST), the CSI 2130 can accurately measure signals on critical low speed equipment that would be out of range for other vibration analyzers. The CSI 2130 also boasts the highest frequency range in the market. It can measure signals up to 80,000 Hz, which is important for accurate diagnosis of centrifugal compressors and other high speed machinery.

## In-field Analysis

There are many route vibration data collectors available for simply getting the normal periodic vibration spectrum and waveform. But when your needs call for an advanced vibration analyzer with analysis tools beyond normal periodic route vibration measurements, then the CSI 2130 is unmatched. The CSI 2130 has advanced in-field analysis tools, including:

- waveform autocorrelation for identifying periodic-versus-random impacting waveform energy.
- fault frequency overlays to match and identify the source of peaks in the vibration spectrum
- trending of up to 12 narrow band parameters for as long as two years, allowing you to see where on the trend your immediate measurement acquisition appears



*The full VGA screen displays standard and PeakVue data at the same time. The PeakVue plot (bottom right) provides clear indication of a rolling element bearing fault that is not visible in the standard reading (bottom left).*

- Fourteen predefined analysis experts (such as coast down, bump tests, time synchronous averaging, order tracking, MCSA, high resolution, high frequency, etc.) for troubleshooting difficult machine problems
- Quad plotting for comparisons of multiple measurements

## Variable Speed Analysis

Variable speed analysis is essential to any effective machinery health program because most critical pieces of equipment must be operated at varying speeds to accommodate the changing production demands. While most vibration systems do not take variable speed into account during data collection, the CSI 2130 automatically adapts all of its diagnostic tools to variable turning speeds during routine data collection. This provides an accurate evaluation of developing problems in the field.

## Predict Catastrophic Failure

Many online monitoring systems installed in plants today serve as nothing more than a shutdown switch in the case of a catastrophic condition. By collecting the signals from these systems with the CSI 2130, you can add predictive capabilities by identifying faults before a catastrophe occurs. Orbit plots can be generated to identify problems such as misalignment and shaft rubs. Trending data also helps to uncover developing cracks and other types of structural faults.

## Monitoring Trouble Spots

The CSI 2130 can also serve as a temporary online monitor. With line power, it is possible to monitor machine health for longer spans up to a month. It can automatically acquire and store data such as the overall vibration, fault frequencies associated with specific fault types, or even the complete spectrum over an extended period of time. You can capture the break-in period for new equipment or to ensure that a machine with a known fault can make it to the next outage.

## Capture Machine Shutdowns

For analysis of transient events, the CSI 2130 collects a series of machine vibration snapshots during startup, coastdown or process changes. These spectra can then be viewed individually or in a Cascade plot.

## Correlate Vibration and Process Variables to Identify Machine Problems

Use the dual-channel feature of the CSI 2130 to correlate machinery vibration with process variables. This is accomplished by inputting the process information as a volt signal into one channel, while monitoring vibration on the other.

## Unsurpassed Versatility

The CSI 2130 incorporates a modular design so that it can be configured to specifically address your current needs. As your needs evolve, the CSI 2130 can be easily and affordably expanded to enhance your capabilities while protecting your initial investment. This versatile unit can be purchased as a single- or dual-channel analyzer – with or without route measurement capability, as a dedicated field balancer, or as a laser alignment calculator. Put together any combination of capabilities to match your requirements. Additional modules are also available for transient and structural analysis.

## Advanced Cross-Channel Analysis

Standard data collection serves as an excellent base for identifying developing machinery faults, but cross-channel analysis is often required to identify the root cause of the fault. Expand the vibration analysis application of the CSI 2130 with the cross-channel module to determine the actual movement of the shaft during operation and to identify structural faults such as cracks and resonances. While the dual-channel CSI 2130 can display orbits for turbomachinery analysis, the optional Advanced Cross-Channel application expands these capabilities to include impact testing and other types of cross-channel analysis.

As a further enhancement, the ODS/Modal application (Operational Deflection Shapes) makes structural analysis simple by automatically configuring the required series of cross-channel tests.

Cross-channel data can also be analyzed in the VibPro module of AMS Machinery Manager, or exported to specialized ODS/Modal analysis software.



*Fault frequency overlays is just one of many advanced analysis tools available in the field with the CSI 2130.*



*The Cascade application captures machine vibration during startup, coast-down, or over an extended period of time. Top half of screen shows spectra individually; bottom half of screen shows cascade plot.*

## Expand the Power of Your CSI 2130 with Transient Analysis

The Advanced Transient Analysis application expands the power of a single- or dual-channel CSI 2130 to record the raw vibration signal over a prolonged period of time for post-processing and analysis. This is essential for diagnostics of turbomachinery, startup and coastdown or machines with short, repetitive duty cycles. This data can be examined directly on the CSI 2130 or in AMS Machinery Manager.

## Field Balancing

The Advanced Balancing application allows you to use the CSI 2130 as a powerful field balancer. This application combines advanced technology with simple, straightforward operation for a fast, effective solution to your balancing problems. The graphical user interface automatically guides you through the balance checklist so that only minimal training is required for effective operation. The application offers a basic mode for simple one- or two-plane balancing and an advanced mode for more complex jobs. Full job documentation can be printed or stored in AMS Machinery Manager.

The Advanced Balancing application offers two solutions to the typical challenges of field balancing:

**Vector Averaging** – This technique systematically removes background vibration that would otherwise contaminate the calculated solution.

**Balancing Watchdog** – This patented technology automatically checks the vibration data on the machine while you perform the balance job. The Watchdog is able to identify and alert you of severe structural faults (such as looseness or resonance) that would otherwise make the job difficult or impossible to complete. The user can take corrective action to remove the structural fault, balance the rotor, and leave the machine in reliable operating condition.

## Laser Alignment

The Advanced Laser Alignment application offers a graphically-driven user interface and wireless operation to quickly and easily complete alignment jobs. Emerson's advanced laser system uses built-in dual inclinometers to automatically determine the shaft position, so you simply rotate the shaft and the solution is plotted on the screen. The Live Move option updates the change in alignment condition during the machine move. Full job documentation is available in AMS Machinery Manager.



*The Advanced Transient Analysis application records the vibration signature from machine startup, coastdown or during process disruptions for advanced analysis.*

The Live Move option updates the change in alignment condition during the machine move. Full job documentation is available in AMS Machinery Manager.

The Laser Alignment Expansion Pak adds this important capability to any CSI 2130.

## Motor Current Analysis

Together with the MotorView® module in AMS Machinery Manager, the CSI 2130 performs non-intrusive analysis of the rotor and stator condition in induction motors. This can be accomplished with a standard current clamp or Emerson's patented flux monitoring.

## Industrial Ratings

Designed for use in industrial environments, the CSI 2130 has received an IP 65 rating certifying that is dust- and splashwater-tight. It also complies with international safety standards for hazardous areas in the United States, Canada and Europe.

## Accessory Options

### Speed Detection

Accurate detection of the shaft turning speed is critical to effective machinery health analysis. The CSI 430 Laser Speed Sensor allows you to determine shaft speed without requiring reflective tape or specific markings on the machine.

### Triaxial Accelerometer

The Model A0643TX is a revolutionary new triaxial sensor. This sensor can be magnet mounted to the machine and still provide high-quality readings in all three directions.

### Proximity Probe Connections

To measure orbits on a protection system, use BNC-type cables and the dual-volt adapter. The phase reference can be read using the generic tach cable.

### Structural Analysis

For advanced structural analysis, use the modally-tuned hammer listed at the bottom of page 11. See pages 10 -12 for additional accessory listings.



*Applications for Advanced Balancing and Alignment make it possible to detect and correct machinery faults with the same CSI 2130.*

## General Specifications

Physical Data	
Color Display	5.75" x 4.25" (146 mm x 108 mm) Transflective (for indoor or outdoor use) liquid crystal display, built-in backlight, 640 x 480 pixel
Key Pad	Oversized, easy to press keys, 12 soft function keys, context sensitive help key
Dimensions	8" (203 mm) high, 1.88" (48 mm) deep, 10.25" (260 mm) wide
Weight	4.5 lbs (2.04 kg)
Operating Conditions	
Moisture	Sealed enclosure, IP-65 rated
Temperature	15 to 113 °F (-10 to 50 C)
Supply	
Battery	NiMH
	4.5 amp hours
	7.2 V
	8 hours typical use (longer with backlight off). Data saved in the event of low battery voltage.
	Discharge/Fastcharge/Trickle charge "Smart Charger". Also functions as a continuous power supply.
	3 hours recharge time
Quality Assurance	NIST Traceable calibration. Safety rated versions available, approved to Class I, Division II rating for Groups A,B,C, & D. Performance specifications for safety rated version are identical to standard model.

**The CSI 21302Q is approved for use in the following areas:**

- FM: Class I, Division 2, Groups A, B, C and D, Temperature Code T4A @ Ta = 50C, CLI, Zone 2, IIC, Non Incedive, T4
- CSA: Class I, Division 2, Groups A, B, C and D, Temperature Code T4A @ Ta = 50C Ex nA IIC, T4 @ Ta = 50C
- ATEX: CE EX II 3 G, Ex nL IIC T4

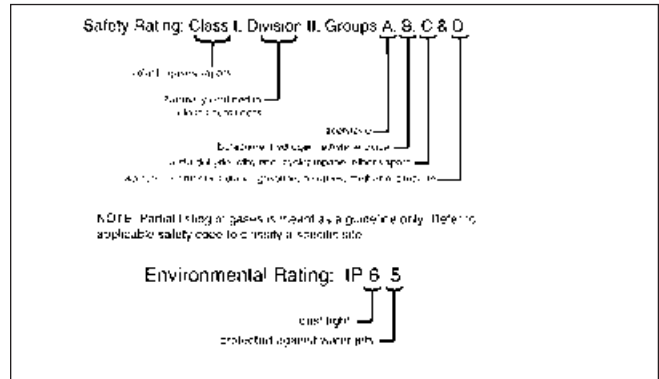

**Analyze & Route Specifications**

**Analysis Experts**

Interactive data acquisition setups for the following analysis types:

High Frequency, High Resolution, Bearing/Gear Fault analysis, Low Frequency, Order Tracking, Synchronous Time Averaging, Bump Test (on and off-line), Coastdown (peak-hold and peak/phase), Turning Speed Detection (vibration and laser), Rotor Fault Detection, Cross-Channel Phase\*, and Orbit Analysis\*.

**Data Analysis Speed**

400 line / 1000 Hz spectrum	0.14 sec/avg
1600 line / 1000 Hz spectrum	0.5 sec/avg

**Analysis Capabilities**

Noise Floor	Less than 0.2 micro-volts per root Hz over 1,000 Hz
PeakVue	Built in, with selectable filters
Demodulation	Built in, with selectable filters
SST	Built in Low Frequency processing
Dual-Channel*	Fully matched, independently configurable. Simultaneous dual channel collection. Filtered Orbit analysis.
Cross-Channel*	Synchronized cross channel Phase and Coherence (Full Spectrum or Single Frequency)
Dynamic Analysis*	Overall, Spectra, Waveform, 12 analysis parameters, 1/3 Octave, A-weighting, Phase, Bode/Nyquist
Signal Range	Autoranging maintains optimum dynamic range. 16 bit A/D Converter has 96 dB Dynamic Range, (coupled with analog integration provides better than 120 dB for typical applications).
Frequency Range	740 ranges from DC-10 Hz to DC-80 kHz.
Low Frequency Response	DC coupling on non-powered inputs allows flat response to DC for non-integrated signals.
Resolution	1/3 Octave, 100, 200, 400, 800, 1600, 3200, 6,400, 12,800 lines. True Zoom provides effective resolution of up to 300,000 lines.
Averaging	Normal, Exponential, Peak Hold, Order Tracking, Synchronous Time, and Negative Averaging
Number of Averages	5,000 in route mode, 10,000 in Job mode, unlimited in Monitor mode
Integration	None, Single, Double (Analog or Digital)
Trigger	Vibration level, Pretrigger, Tach, Pretach
Anti-Aliasing	Filters attenuate all alias components to below noise floor

Amplitude Units	Metric or English, acceleration, velocity, displacement, or user programmable
Frequency Units	Hz, CPM, Orders
Scaling	Linear or Log, both X and Y axes
Windows	Hanning or Uniform
Cursor	Single, Harmonic, Moving Harmonic, Sideband
Memory	512 MB internal memory for data storage Secure digital memory card slot for virtually unlimited memory

Signal Input	
Powered Inputs	(2 mA, +20 V ICP power supply) +/- 15 V
Non-Powered Inputs	+/- 24 V range
Input Impedance	Greater than 125 k ohms
Tach	TTL input, built in conditioning for non TTL signals, adjustable trigger
Pseudo tach	Generates tach pulses for hidden shafts
Triaxial	Internal multiplexer for automatic sequencing of triaxial measurements
Output	Communication with host computer with USB, ethernet, or emailable data files USB data stick file transfer*

**Balancing Specifications**

Basic Mode offers	
	Pre-configured jobs for single and two plane balancing
	Full calculator mode

Advanced Mode adds	
	Up to 4 planes
	Up to 8 sensor inputs
	Up to 6 different speeds
	Automatic unit conversion
	Automatic weight splitting
	Trial weight estimation

Special Features	
Vector Averaging	Eliminates background vibration
Balancing Watchdog	Automatically detects secondary machinery faults
Graphic User Interface	Provides data stability indicator Displays live imbalance vector Eliminates confusion about weight placement

**Alignment Specifications**

**Basic Mode offers**

- Auto sweep (includes partial sweep)
- Manual 4 point
- Soft foot detection
- Thermal growth compensation
- Live machine moves
- Jackshaft applications
- Record notes and observations
- Store and recall jobs

**Advanced Mode adds**

- QuickSpec alignment checker
- Manual sweep
- Dual pass mode (uncoupled shafts)
- Vertical machine alignment
- C-face alignment
- Straightness measurement
- Enhanced soft foot detection
- Data averaging
- Custom machine configuration
- Custom tolerance values
- Additional live move options
- Upload jobs to software

**Communication**

- Standard via cables
- Cableless measurement
- Optional RF (where permitted)

**Special Features**

- Thermal growth compensation
- Live machine moves
- Jackshaft applications
- Record notes and observations

Part No.	Description	Application						Vib.		S/W	Ratings		
		Route	Analyze	Cascade	Balance	Basic Align	Adv. Align	1 ch.	2 ch.	Ultra Mgr	FM	CSA	ATEX
A2130D1	1 ch. collector	✓						✓					
A2130D1Q	Safety-rated 1ch. collector	✓						✓			✓	✓	✓
A2130A1	Std. 1 ch. Route/Analyze/Cascade	✓	✓	✓				✓					
A21301Q	Safety-rated 1 ch. Route/Analyze/Cascade	✓	✓	✓				✓			✓	✓	✓
A2130A2	Std. 2 ch. Route/Analyze/Cascade	✓	✓	✓					✓				
A21302Q	Safety-rated 2 ch. Route/Analyze/Cascade	✓	✓	✓					✓		✓	✓	✓
A8130Z1	1 ch. Vibration Analyzer Package		✓	✓				✓					
A8130Z2	2 ch. Vibration Analyzer Package		✓	✓					✓				
A8130B1	1 ch. Adv. Balance Analyzer Package				✓			✓		✓			
A813025-IN	Adv. Laser Align Pkg / 8225 cabled heads									✓			
A813025-CU	Adv. Laser Align Pkg / 8225 RF heads									✓			

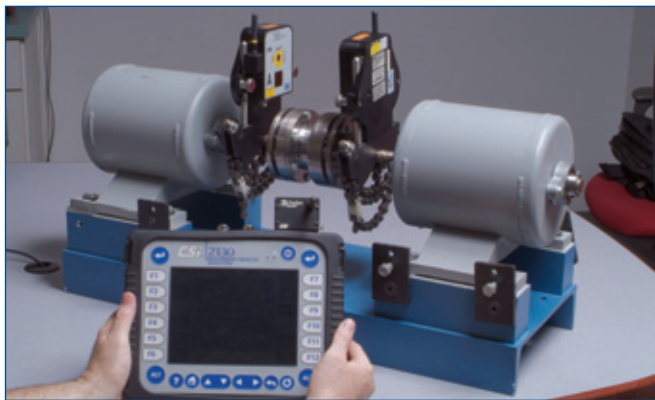

CSI 8225 Laser Heads

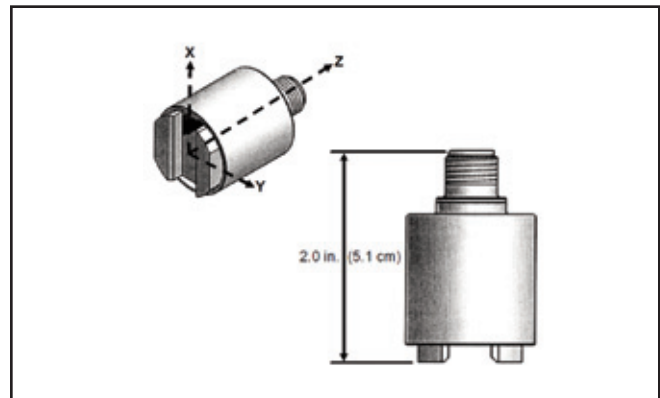

Emerson's patented triaxial sensor with integral magnet

Part Number	Description
<b>Firmware Application</b>	
A2130S0	Route/Analyze/Cascade applications
A2150S1	Route application
A2130S2	Analyze application
A2130S3	Advanced Cross-Channel application
A2130S4	Transient application
A2130S5	ODS/Modal application
A2130S7	Advanced Balancing application
A2130S8	Basic Laser Alignment application
A2130S9	Advanced Laser Alignment application
<b>Standard Accessories</b>	
D24642	CSI 2130 protective rubber jacket
A063902	USB communications cable
MHM-64986	Ethernet Communication cable
D24899	CSI 2130 hand strap - qty 2

D24834	CSI 2130 hand pad - qty 2
D24933	Shoulder strap for vibration meters
D24892	Hardshell carrying case
93140	Power supply
65010	Power cord
91413	Screen protector starter pack - Reorder using P/N 91411
<b>Vibration Measurement Accessories</b>	
A0760GP	Accelerometer
A0643TX	Triaxial Accelerometer with integral magnet
A090835	Magnet
A6121BL	Cable, 2-pin MIL to BNC, blue, 4'
A6121RD	Cable, 2-pin MIL to BNC, red, 4'
D24844	Coiled accelerometer cable, 2-pin to Turck, 8' extended
D25064	Triaxial accelerometer cable
A06280A	Dual-channel accel adapter, 25-pin to 2 BNC
D24826	Triaxial accelerometer keyed mounting pad
<b>Balancing Accessory Package</b>	
A648	4-channel multiplexer
A0404P1	1 - 20K RPM Infrared Phototach Kit, including: <ul style="list-style-type: none"> <li>■ A040801 - Phototach power supply</li> <li>■ A403 - Reflective tape (3 rolls)</li> <li>■ 24862 - Phototach cable</li> </ul>
D24786	Hard shell suitcase
<b>Standard Laser Accessories</b>	
D23465	Mounting posts (4)
A8211	Super-fast smart charging station
A8AA10	Tape measure
A821510	Direct connect cable
99451	Screwdriver
D24492	Hard shell suitcase
A8AA55	Quick mount brackets & chains (2) - Basic Package only
B821007	Standard mount brackets (2) - Adv. Package only
B8210-CHN	Standard mount chains (2) - Adv. Package only
99510	Hex ball driver- Adv. packages only
B8100-EXT2	Extension Blocks (2) - Adv. packages only
A8215C2-PM	Pass Mode Cable - RF packages only
B8000RF	RF adapter - RF packages only

<b>Expansion Paks</b>	
A1730B1	Balance Expansion Pak for 2130
A873025-IN	Adv. Laser Expansion Pak - 20x20 mm cabled heads
A873025-CU	Adv. Laser Expansion Pak - 20x20 mm RF heads
<b>Phototachs, Strobes, and Speed Sensors</b>	
A0430L3	SpeedVue laser speed sensor package for 2130
A0404B1	404B IR Phototach for 2130
A0404P1	404B IR Phototach for 2130 with external power
A0555-30	Computerized strobe light package for 2130
<b>Special Vibration Sensors</b>	
A0120LF	Low frequency accel, top connect, 2 pin
A0220HF	High frequency accel, top connect, 2 pin
A0222H1	60 kHz high freq. accel, top connect, stud mount
A0222H2	60 kHz high freq. accel, top connect, epoxy mount
A0623SS	SST kit for low frequency measurements
<b>Modally-Tuned Impact Hammer</b>	
A034701	1 lb Small Modal Force Hammer
A034703	3 lb Mini-Sledge Modal Force Hammer
A034712	12 lb Sledge Modal Force Hammer
<b>Adapters</b>	
A06290V	Dual-channel volt adapter, 25-pin to 2 BNC
A06280A	Dual-channel accel adapter (Turck connectors)
A648	4-channel accelerometer input multiplexer for 2130



CSI 430 Laser Speed Sensor



CSI 555 Strobe Light

<b>Phototachs, Strobes, and Speed Sensors</b>	
A0430L3	SpeedVue laser speed sensor package for 2130
A0404B1	404B IR Phototach for 2130
A0404P1	404B IR Phototach for 2130 with external power
A0555-30	Computerized strobe light package for 2130
<b>Special Vibration Sensors</b>	
A0120LF	Low frequency accel, top connect, 2 pin
A0220HF	High frequency accel, top connect, 2 pin
A0222H1	60 kHz high freq. accel, top connect, stud mount
A0222H2	60 kHz high freq. accel, top connect, epoxy mount
A0623SS	SST kit for low frequency measurements
<b>Modally-Tuned Impact Hammer</b>	
A034701	1 lb Small Modal Force Hammer
A034703	3 lb Mini-Sledge Modal Force Hammer
A034712	12 lb Sledge Modal Force Hammer
<b>Adapters</b>	
A06290V	Dual-channel volt adapter, 25-pin to 2 BNC
A06280A	Dual-channel accel adapter (Turck connectors)
A648	4-channel accelerometer input multiplexer for 2130
<b>Current Clamps</b>	
A341B	Clip-on AC current clamp (1.0 to 600 Amp AC)
A341C	Clip-on AC current clamp (50 mA to 150 Amp AC)
A341D	Clip-on AC current clamp (0.1 to 1000 Amp AC)
<b>Cables</b>	
D24859	CSI 2130 Volts straight cable, BNC to Turck, 4' long
D24861	CSI 2130 tach cable, 404B connector to blue Turck, 2 m
D24862	CSI 2130 tach cable, BNC to blue Turck, 4'
D24863-1	CSI 2130 SpeedVue cable, LEMO to Turck, 18" long
D24863-2	CSI 2130 SpeedVue cable, LEMO to Turck, 6 ft. long
D24973	CSI 2130 accel/hammer straight cable, BNC to Turck, 6.5' (2m)
D24809-2	SpeedVue cable for 2120A (6 ft. long)
65116	Ext. cable for Turck accel connector, 6' 5"
65117	Ext. cable for Turck accel connector, 19' 8"
65118	Ext. cable for Turck tach connector, 6' 5"
65119	Ext. cable for Turck tach connector, 19' 8"
<b>Battery Pack</b>	
D24777	Battery Pack for A2130A2
D24974	Battery Pack for A21302Q

Other Accessories	
A0130FS	Folding desk stand for CSI 2130
91411	CSI 2130 Adhesive screen protectors (10 pack)
D24937	SpeedVue mounting strap for 2130
97017	CSI 2130 printed user manual

Note: Descriptions are for illustrative purposes only. Packages and part numbers are subject to change without notice.



Current Clamps

**Emerson Process Management**  
**Asset Optimization**  
835 Innovation Drive  
Knoxville, TN 37932  
T (865) 675-2400  
F (865) 218-1401  
[www.EmersonProcess.com](http://www.EmersonProcess.com)

©2012, Emerson Process Management.

The contents of this publication are presented for informational purposes only, and while every effort has been made to ensure their accuracy, they are not to be construed as warranties or guarantees, express or implied, regarding the products or services described herein or their use or applicability. All sales are governed by our terms and conditions, which are available on request. We reserve the right to modify or improve the designs or specifications of our products at any time without notice.

All rights reserved. PlantWeb, AMS, Machinery Health, and PeakVue are marks of one of the Emerson Process Management group of companies. The Emerson logo is a trademark and service mark of Emerson Electric Co. All other marks are the property of their respective owners.