

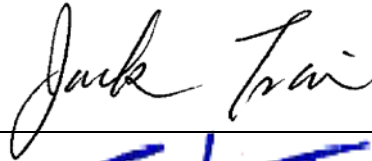

Report No.	B25CE100205
Directives Specifications	89/336/EEC, 92/31/EEC, 93/68/EEC, 2004/108/EC EMC/EN 61000-6-3/2001; EN 55024/1998+A1+A2, AS/NZS CISPR 22
Applicant Applicant address	POWERSOLVE ELECTRONICS LTD. Units 8A Arnhem Road,, Newbury, RG14 5RU
Items tested	Power Supply
Model No.	PSS40-1212
EUT Condition	<input checked="" type="checkbox"/> Engineering sample; <input type="checkbox"/> Pre-production; <input type="checkbox"/> Final production (Sample # B25100205)
Results	Compliance (As detailed within this report)
Date	12/22/2010 (month / day / year) (Sample received) 12/29/2010 ~ 01/05/2011 (Test)
Prepared by	 Project Engineer (Jack Tsai)
Authorized by	 General Manager (Frank Tsai)
Issue date	January 07, 2011 (month / day / year)
Modifications	None
Tested by	Training Research Co., Ltd.
Office at	No. 255, Nan Yang Street, Shijr City, Taipei Hsien 221, Taiwan
Open site at	No. 15, Lane 530, Balian Rd., Sec. 1, Shijr City, Taipei Hsien 221, Taiwan

Conditions of issue :

- (1) This test report shall not be reproduced except in full, without written approval of TRC. And the test result contained within this report only relate to the sample submitted for testing.**
- (2) This report must not be used by the client to claim product endorsement by NVLAP or any agency of U.S. Government.**
- (3) This test report, measurements made by TRC are traceable to the NIST only Conducted and Radiated Method.**



Contents

CHAPTER 0	EMISSION AND SUSCEPTIBILITY STANDARDS.....	4
	Emission Standards	4
	Susceptibility Standards	4
CHAPTER 1	INTRODUCTION	5
	Description of EUT	5
	Connections of EUT	5
	Test method	5
	Configuration of Test Setup	6
	Connections of equipment.....	6
	List of Support Equipment	6
CHAPTER 2	CONDUCTED EMISSION TEST	7
	Test condition and setup.....	7
	List of test Instrument	8
	Conducted Test Placement: (Front view and Side view)	9
CHAPTER 3	RADIATED EMISSION TEST	10
	Test condition and setup.....	10
	List of test Instrument	11
	Radiated Test Placement: (Front view and Rear view).....	12
CHAPTER 4	ELECTROSTATIC DISCHARGES IMMUNITY TEST	13
	ESD Test information:	13
	EN 61000-4-2 PHOTO OF TEST SET-UP	16
CHAPTER 5	RADIO FREQUENCY IMMUNITY TEST.....	17
	RS Test information:	17
	EN 61000-4-3 PHOTO OF TEST SET-UP	20
CHAPTER 6	ELECTRIC FAST TRANSIENT/BURST REQUIREMENTS TEST... 	21
	EFT Test information:.....	21
	EN 61000-4-4 PHOTO OF TEST SET-UP	24
CHAPTER 7	SURGE IMMUNITY TEST.....	25
	Surge Test information:.....	25
	EN 61000-4-5 PHOTO OF TEST SET-UP	27

- CHAPTER 8 CONTINUOUS WAVE VOLTAGE IMMUNITY TEST 28**
 - CS Test information: 28
 - EN 61000-4-6 PHOTO OF TEST SET-UP 30

- CHAPTER 9 VOLTAGE DIP / INTERRUPTION TEST 31**
 - DIP Test information: 31
 - EN 61000-4-11 PHOTO OF TEST SET-UP 33

- CHAPTER 10 HARMONICS TEST..... 34**

- CHAPTER 11 VOLTAGE FLUCTUATION AND FLICKER TEST..... 35**

- APPENDIX A 36**
 - Test Result of Conducted Emissions for Mains power 36

- APPENDIX B 37**
 - Test Result of Radiated Emission (Horizontal) 37
 - Test Result of Radiated Emission (Vertical)..... 37

- APPENDIX C 38**
 - Photographs of EUT 38

Chapter 0 Emission and Susceptibility Standards

Emission Standards

Emission Standard	European Standard	International Standard
(X)	EN 61000-6-3/2007	IEC 61000-6-3/2007
()	EN 61000-6-4/2001	IEC 61000-6-4/1997
()	EN 50081-1/1992	
()	EN 50081-1/8.93	
()	EN 55014/4.93	CISPR 14: 1993
()	EN 55015/12.93	CISPR 15: 1992
()	EN 55013/2001	CISPR 13: 2001
(X)	EN 55022/2006+A1/2007	CISPR 22: 2005
(X)	EN 61000-3-2/2006	IEC 61000-3-2:2005
(X)	EN 61000-3-3/2008	IEC 61000-3-3: 2008

Susceptibility Standards

Susceptibility Standard	European Standard	International Standard
()	EN 61000-6-1/2001	IEC 61000-6-1/1997
()	EN 61000-6-2/2001	IEC 61000-6-2/1999
()	EN 50082-1/1997	
()	EN 50082-2/1994	
(X)	EN 55024/1998+A1/2001+A2/2003	CISPR 24/1997
()	EN 55020/2002	CISPR 20/2002
(X)	EN 61000-4-2:2009	IEC 61000-4-2:2008
(X)	EN 61000-4-3:2006 +A1/2008	IEC 61000-4-3:2006
(X)	EN 61000-4-4:2004	IEC 61000-4-4:2004
(X)	EN 61000-4-5:2006	IEC 61000-4-5:2005
(X)	EN 61000-4-6:2009	IEC 61000-4-6:2008
()	EN 61000-4-8:1993+A1/2001	IEC 61000-4-8:1993+A1/2000
(X)	EN 61000-4-11:2004	IEC 61000-4-11:2004

Chapter 1 Introduction

Description of EUT

The EUT is a battery charger

(I/P: 100-240VAC, 50-60Hz, 0.75A; O/P: 1: 5-12.6Vdc/1A max;

O/P 2: 5.7-13.6Vdc/2A max, combined 2A max).

Connections of EUT

(1)The primary cable of EUT is connects to power source.

(2)The secondary cable of EUT is connects to dummy load.

Test method

Pretest was found that the emission of operating mode is worse than standby mode. So, the final test is made at the load.

During testing the EUT is loading at continuously.

The test placement as the photographs showed is the worst case emission placed. (If the emission is close to the ambient, the resolution BW and view resolution will be reduced and the data will be recorded by detection of maximum hold peak mode.)

Deviation from test standard: No deviation.

The testing configuration of test setup is showing in the next page.

Configuration of Test Setup

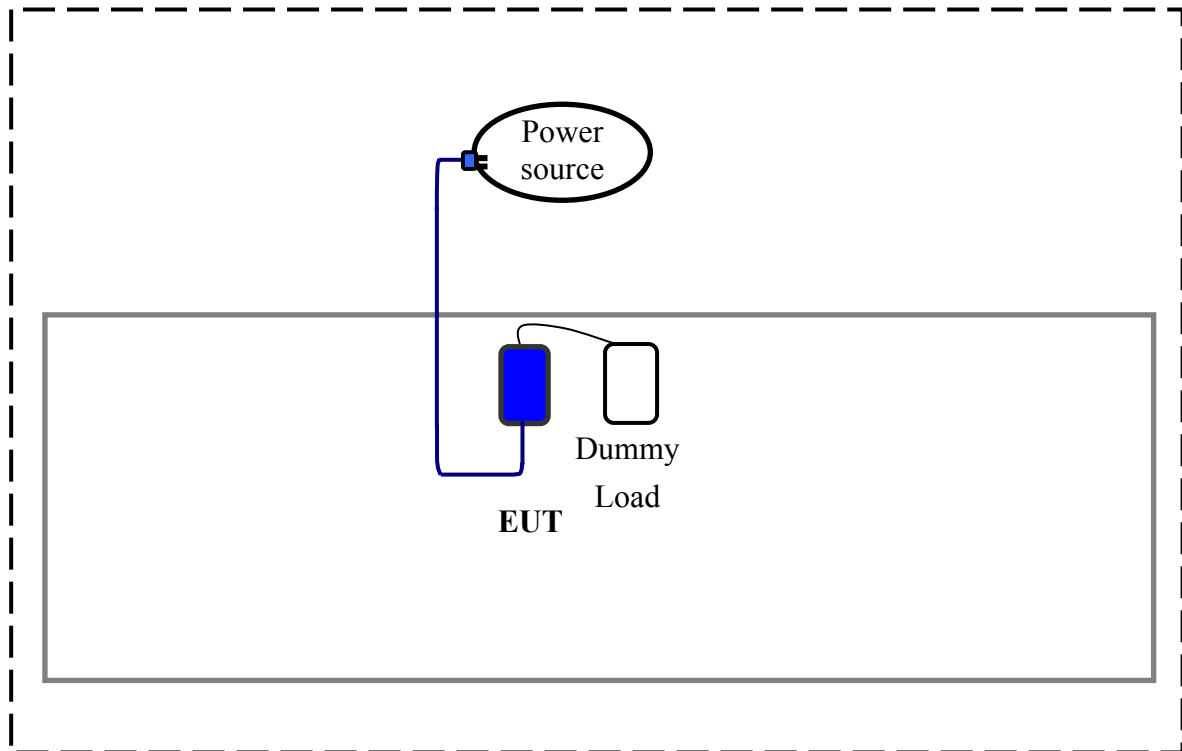

Connections of equipment

EUT:

- * Secondary Power Cable x 1 ... 1.88m length, shielded, without ferrite core
- * Primary Power Cable x 1 1.83m length, non-shielded, without ferrite core

List of Support Equipment

Dummy Load : 9.2 Ohm *2 (Max. loaded)

Chapter 2 Conducted Emission Test

Test condition and setup

All the equipment is placed and setup according to *EN 55022*.

Mains power:

The EUT is assembled on a wooden table, which is 80 cm high and placed 40 cm from the back-wall, which is a vertical conducting plane. One LISN is for EUT, the other LISN is for support equipment. They are all placed on the conductive ground. The EUT's LISN connect a line switch box for selecting L1 or L2, then connect to a preamplifier and spectrum.

The spectrum scans from 150KHz to 30MHz. Conducted emission levels are detected at *maximum peak mode*. But if the maximum peak mode failed or over *average limit*, it will be measured by *average detection mode*.

While testing the worst-emission plot printed in the *peak detection mode*, and there are up to 6 highest emissions to be recorded. The plot is kept as the original data and not included in the test report.

List of test Instrument

				Calibration Date
Instrument Name	Model No.	Brand	Serial No.	Next time
EMI Receiver	ESCI	Rohde & Schwarz	100027	09/14/11
LISN	3825/2	EMCO	9411-2284	01/15/11
LISN	3825/2	EMCO	9210-2007	01/15/11
Switch Box	Sb-01	TRC	98-04	10/01/11
Pre-amplifier (<30Mhz)	CNIJ69051	TRC	96061	10/01/11
Coaxial cable	BNC3200B-0058	Jyebao	CL-003	10/01/11
Coaxial Cable	BNC31VB-0316	Jyebao	IF-01C0069-036	10/01/11
Coaxial Cable	BNC3200B-0058	Jyebao	CL-05	10/01/11
Isolation Transformer	FTB-1-6	Mini-circuits	15542	10/01/11
20dB attenuator	CAT-20	min-circuits	960113	10/01/11
50 Ohm Terminator	370BNM	Narda	PWR5W	01/15/11
50 Ohm Terminator	370BNM	Narda	PWR5W	01/15/11
50 Ohm Terminator	370BNM	Narda	PWR5W	01/15/11
50 Ohm Terminator	370BNM	Narda	PWR5W	01/15/11

The level of confidence of 95%, the uncertainty of measurement of conducted emission is +3.10dB / -4.84dB.

Test Result: Pass (Appendix A)

Conducted Test Placement: (Front view and Side view)



Chapter 3 Radiated Emission Test

Test condition and setup

Pretest:

Prior to the final test (OATS test), the EUT is placed in an anechoic chamber, and scan from 30MHz to 1GHz. This is done to ensure the radiation is exactly emitted from the EUT.

Final test:

Final radiation measurements are made on a **10 – meter, open-field** test site. The EUT is placed on a nonconductive table, which is 0.8m height, the top surface is 1.0 x 1.5 meter. The entire placement is according to *EN 55022*.

The spectrum is examined from 30MHz to 1GHz measured by HP spectrum. The whole range antenna is used to measure frequency from 30MHz to 1GHz.

The final test is used the spectrum analyzer. Measure more than six top marked frequencies generated form pretest by computer step by step at each frequency. The EUT is rotated 360 degrees, and antenna is raised and lowered from 1 to 4 meters to find the maximum emission levels. The antenna is used with both horizontal and vertical polarization. Appropriated preamplifier which is made by TRC is used for improving sensitivity and precautions is taken to avoid overloading .The spectrum analyzer's 6dB bandwidth is set to 120kHz, and the EUT is measured at quasi-peak (below 1GHz) mode.

If the emission is close to the frequency band of ambient, the tester will recheck the data and the corrected data will be written in the test data sheet. If the emission is just within the ambient, the data from shielded room will be taken as the final data.

List of test Instrument

				Calibration Date
Instrument Name	Model No.	Brand	Serial No.	Next time
EMI Receiver	8546A	HP	3520A00242	03/12/11
RF Filter Section	85460A	HP	3448A00217	03/12/11
Small Biconical Antenna	UBAA9114 & BBVU9135	Schwarzeck	127	09/21/11
Pre-amplifier	PA1F	TRC	1FAC	10/06/11
Auto Switch Box (>30MHz)	ASB-01	TRC	9904-01	10/06/11
Coaxial Cable (Double shielded, 15 meter)	A30A30-0058-50FS -15M	JYEBAO	SMA-01	10/06/11
Coaxial Cable (1.1 meter)	A30A30-0058-50FS -1M	JYEBAO	SMA-02	10/06/11
EMI Receiver	ESCI	ROHDE & CHWARZ	100027	09/14/11
Bi-log Antenna	VULB 9168	SCHWARZEBECK	9168-231	12/23/11
Pre-amplifier	CNIJ69051	TRC	96061	10/01/11
Coaxial cable	N30N30-JBY400	JYEBAO	CL-011	10/01/11
Coaxial Cable	A30A30-0316	JYEBAO	CL-012	10/01/11
Spectrum Analyzer	8564E	HP	3720A00840	03/03/11
Microwave Preamplifier	84125C	HP	US36433002	10/19/11
Horn Antenna	1196E (3115)	HP (EMCO)	9704-5178	01/15/11

The level of confidence of 95% , the uncertainty of measurement of radiated emission is +2.85dB / -2.77dB .

Test Result: Pass (Appendix B)

Radiated Test Placement: (Front view and Rear view)



Chapter 4 Electrostatic Discharges Immunity Test

ESD Test information:

Test setup: Shielded room

Test setup for table-top equipment at laboratory tests:

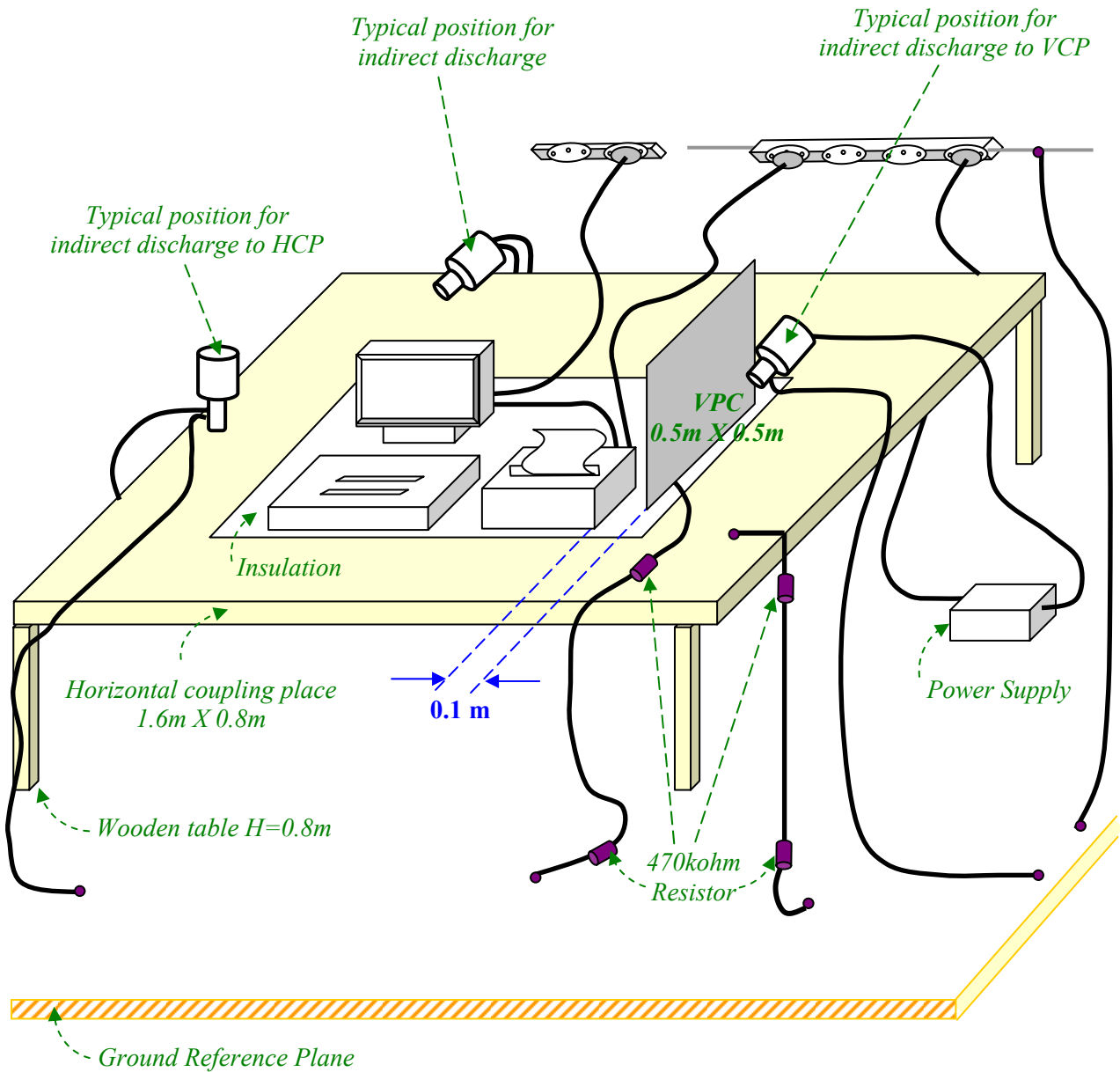

Test levels: (Apply Level 2 and Level 3)

1a — Contact discharge		1b — Air discharge	
Level	Test voltage (kV)	Level	Test voltage (kV)
1	2	1	2
2	4	2	4
3	6	3	8
4	8	4	15
X	Special	X	Special

NOTE: “X” is an open level. The level has to be specified in the dedicated equipment specification. If higher voltages than those shown are specified, special test equipment may be needed.

Test Voltage: 4KV contact discharge
 8KV air discharge

Indirect Discharges: HCP
 VCP

Polarity: Positive
 Negative

Test points: Each Connector and Enclosure of EUT.

Test mode: Ref. Test method of Chapter 1

Test instruments:

Name	Model Number	Serial Number	Selected
Best Plus BURST ESD SURGE TRANSIENTS	Best Plus V6.2	199749-019SC	
SCHAFFNER EMV AG	NSG 438 INA 4380	253	X
BEST EMC Test Instrument	BEST EMC V2.3 (-8, -9)	199918-006SC	

Comment:

Performance Criteria () A (X) B () C

EN 61000-4-2 PHOTO OF TEST SET-UP



Chapter 5 Radio Frequency Immunity Test

RS Test information:

Test setup: Fully anechoic chamber

Radiated Immunity Test Setup

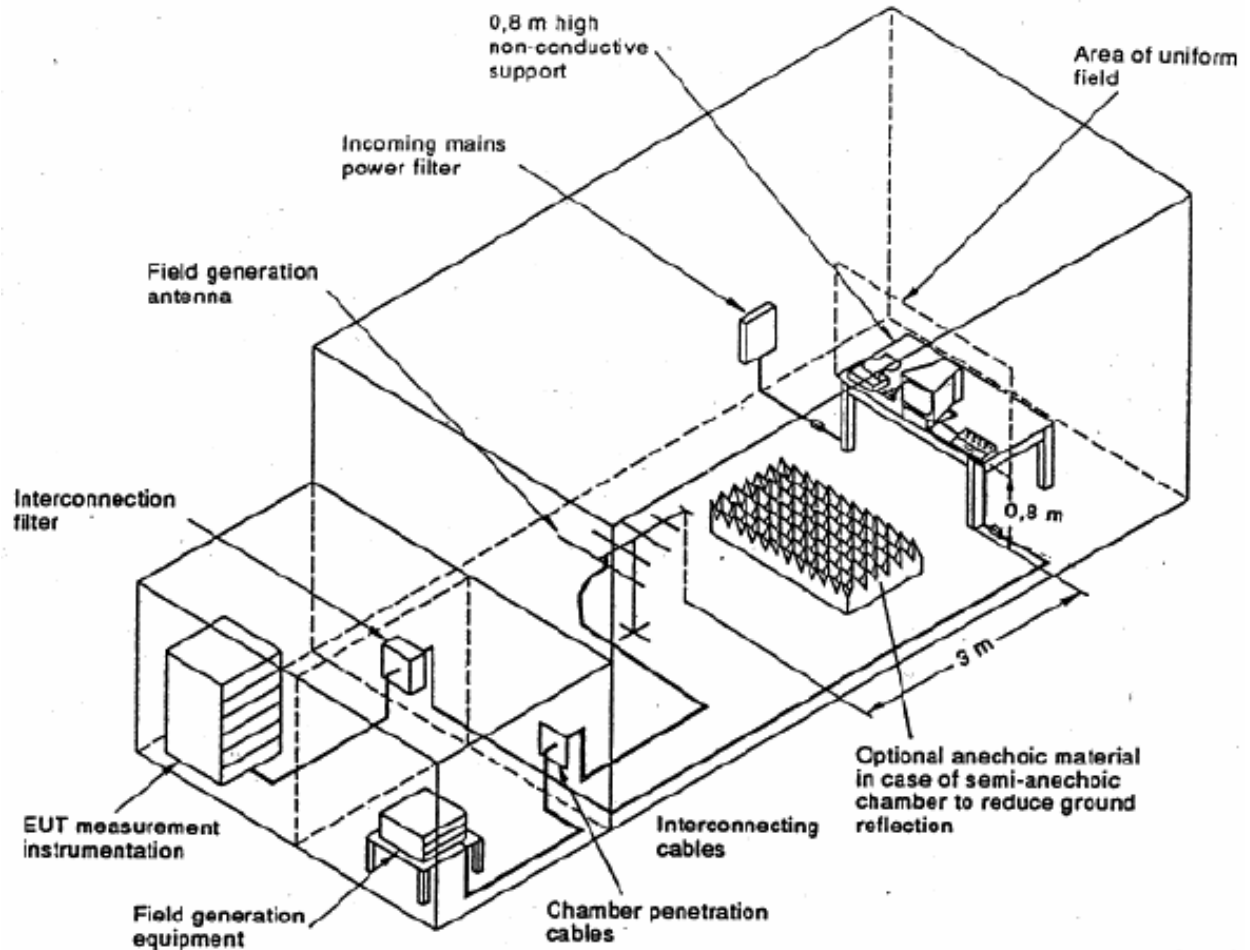

Test levels: (Apply Level 2)

Level	Test Field Strength (V/m)
1	1
2	3
3	10
X	Special

NOTE: the "X" is an open test level. This level may be given in the product specification.

Test Frequency: 80 ~ 1000 MHz
 27 ~ 500 MHz Without Modulation

Modulation: FM %
 80% AM Modulation with 1KHz

Step size: $\leq 1\%$ step size

Sweep time: 2.5 Second for each frequency

Test mode: Refer to test method of Chapter 1

Test instruments:

Name	Model Number	Serial Number	Selected
Amplifier Research RF Amplifier (0.8 – 3GHz)	15S1G3	305899	X
Amplifier Research 40dB Attenuator	DC7144	305930	X
Mini-Circuits RF Amplifier (20 – 500MHz)	LZT-1	N/A	X
Mini-Circuits RF Amplifier (500 – 1GHz)	LZT-2	N/A	X
EMCO Bi-log Antenna	3141	9711-1075	X
TRC Horn Antenna	HA0501-05	RS-01	X
HP Signal Generator	8648D	3613A00117	X
HP Power Meter	E4418B	GB39291240	X
WG radiation meters	EMC-20	BN2244129	X
WG E-filed	2244 / 90.20	Z-0001	X
GW DC Power Supply	GPR-3520HD	A150114	X

EN 61000-4-3 PHOTO OF TEST SET-UP

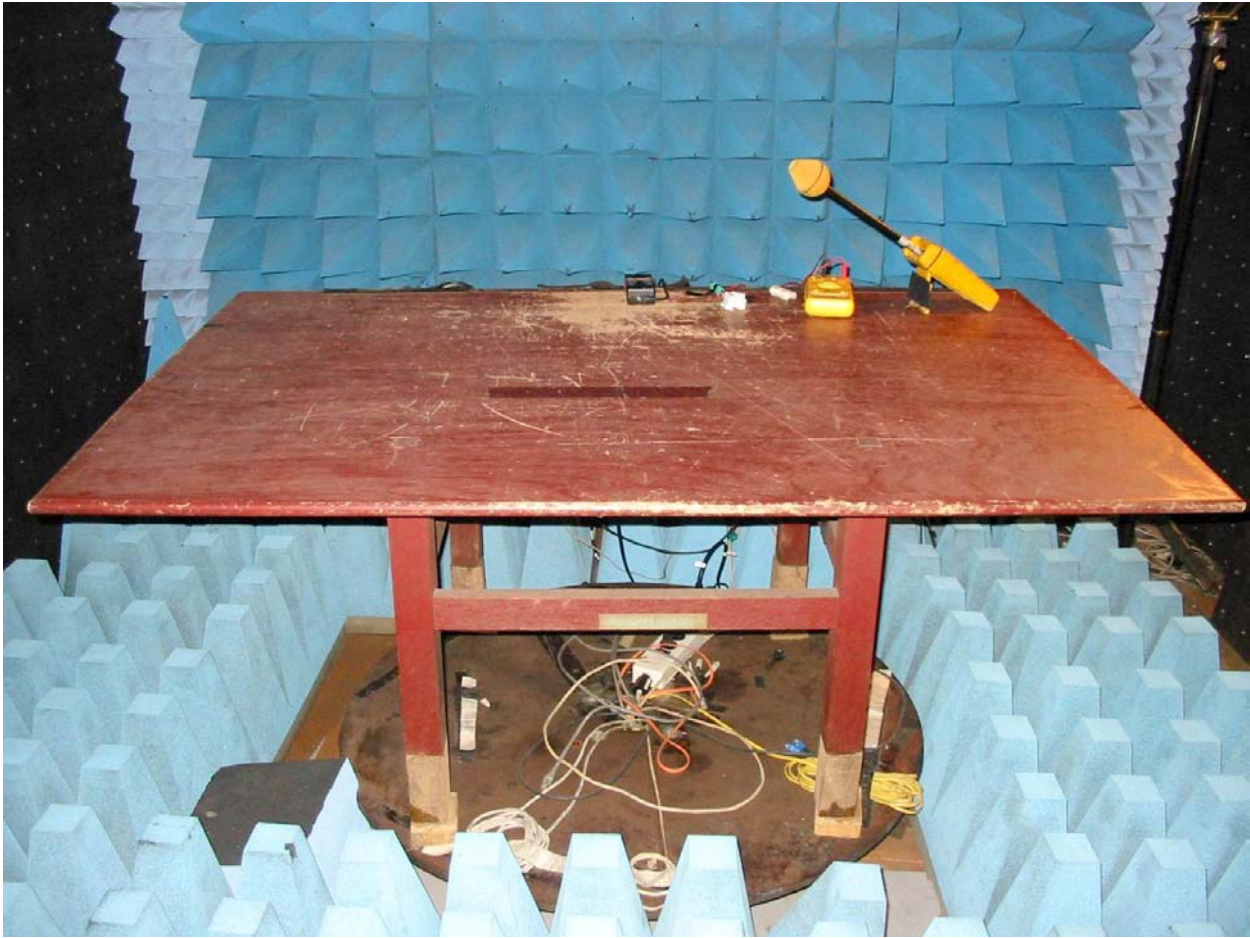

Chapter 6 Electric Fast Transient/Burst Requirements Test

EFT Test information:

General test set-up for laboratory type tests:

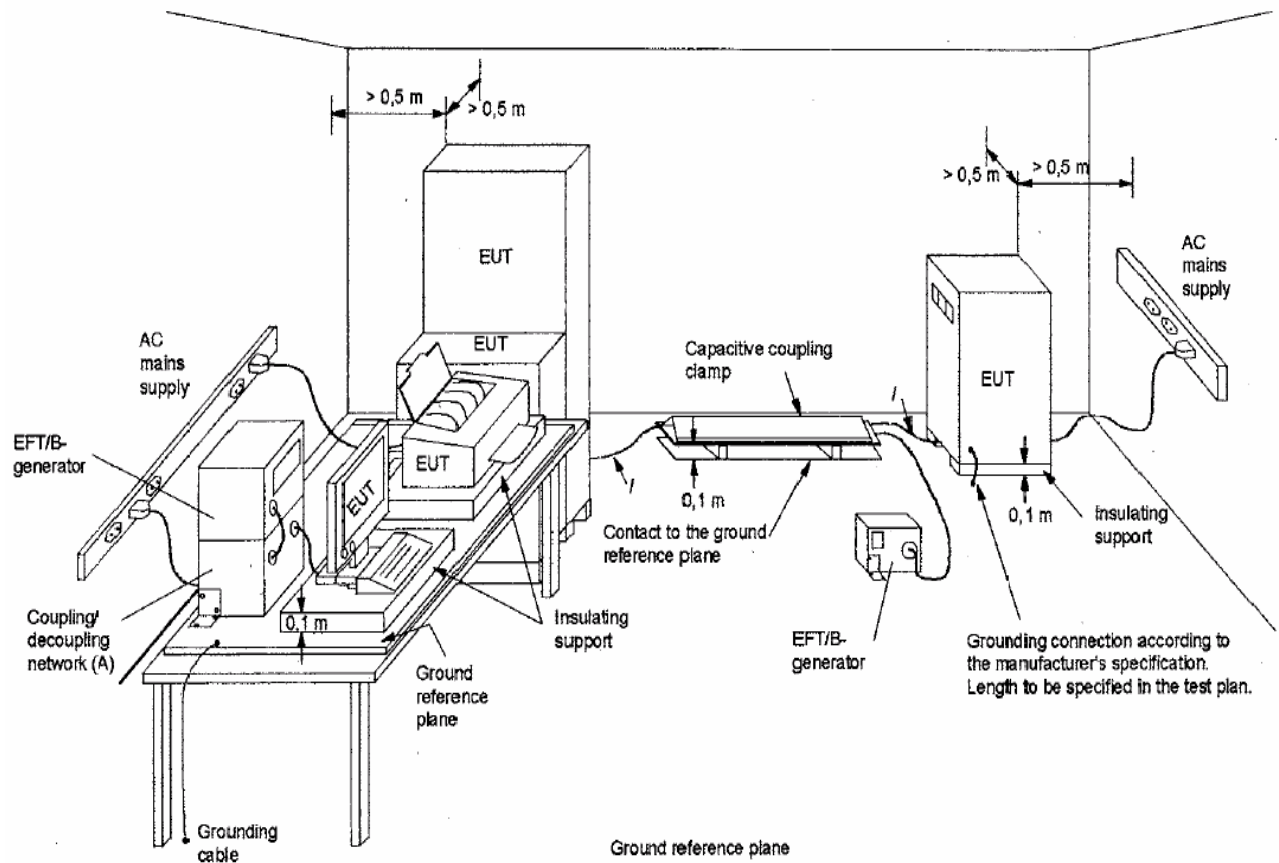

Test levels: (Apply Level 2)

Open-circuit output test voltage ($\pm 10\%$) and repetition rate of the impulses ($\pm 20\%$)				
Level	On power supply port, PE		On input/output signal, data and control ports	
	Voltage peak kV	Repetition rate kHz	Voltage peak kV	Repetition rate kHz
1	0.5	5	0.25	5
2	1	5	0.5	5
3	2	5	1	5
4	4	2.5	2	5
X	Special	Special	Special	Special

NOTE: the "X" is an open level. The level has to be specified in the dedicated equipment specification

Test setup: According to EN 61000-4-4

Test Voltage:

- DC Power line 0.5 KV, 5 KH
- AC Power line 2 KV, 5 KHz
- Signal & Control line 0.5 KV, 5 KHz
- 1 KV, 5 KHz

Polarity:

- Positive
- Negative

Test Duration:

- 1 minute
- 3 minutes

Connected lines:

- Power line shielded
- Power line non-shielded
- Signal & Control line non-shielded
- Signal & Control line shielded

Test mode: Ref. Test method of Chapter 1.

Test instrument:

Name	Model Number	Serial Number	Selected
Best Plus BURST ESD SURGE TRANSIENTS	Best Plus V6.2	199749-019SC	
KeyTek Instrument EFT Test system	E412	9505206/505207	X
BEST EMC Test Instrument	BEST EMC V2.3 (-8, -9)	199918-006SC	

Comment:

Performance Criteria () A (X) B () C

EN 61000-4-4 PHOTO OF TEST SET-UP



Chapter 7 Surge Immunity Test

Surge Test information:

Test setup: According to EN 61000-4-5

Test levels: (Apply Level 2 and Level 3)

Level	Test Field Strength (kV)
1	0.5
2	1.0
3	2.0
4	4.0
X	Special
NOTE: the "X" is an open class. This level may be specified in the product specification.	

- Test Voltage:**
- DC Power line 0.5 KV
 - AC Power line Line – Line: 1KV
 - Line – Ground: 2KV
 - Control line 0.5 KV
 - Signal 1 KV

Voltage waveform: 1.2/50µs

Current waveform: 8/20µs

Polarity:

- Positive
- Negative

Connected lines:

- Power line shielded
- Power line non-shielded
- Signal & Control line non-shielded
- Signal & Control line shielded

Test mode: Ref. Test method of Chapter 1.

Test instrument:

Name	Model Number	Serial Number	Selected
Best Plus BURST ESD SURGE TRANSIENTS	Best Plus V6.2	199749-019SC	
BEST EMC Test Instrument	BEST EMC V2.3 (-8, -9)	199918-006SC	
KeyTek Pulsed-EMI Test System	E501B	0008260	X
KeyTek Pulsed-EMI Test System	E4552A	0008264	X

Comment:

Performance Criteria: A B C

EN 61000-4-5 PHOTO OF TEST SET-UP



Chapter 8 Continuous Wave Voltage Immunity Test

CS Test information:

Test setup: According to EN 61000-4-6

Immunity test to RF conducted disturbances:

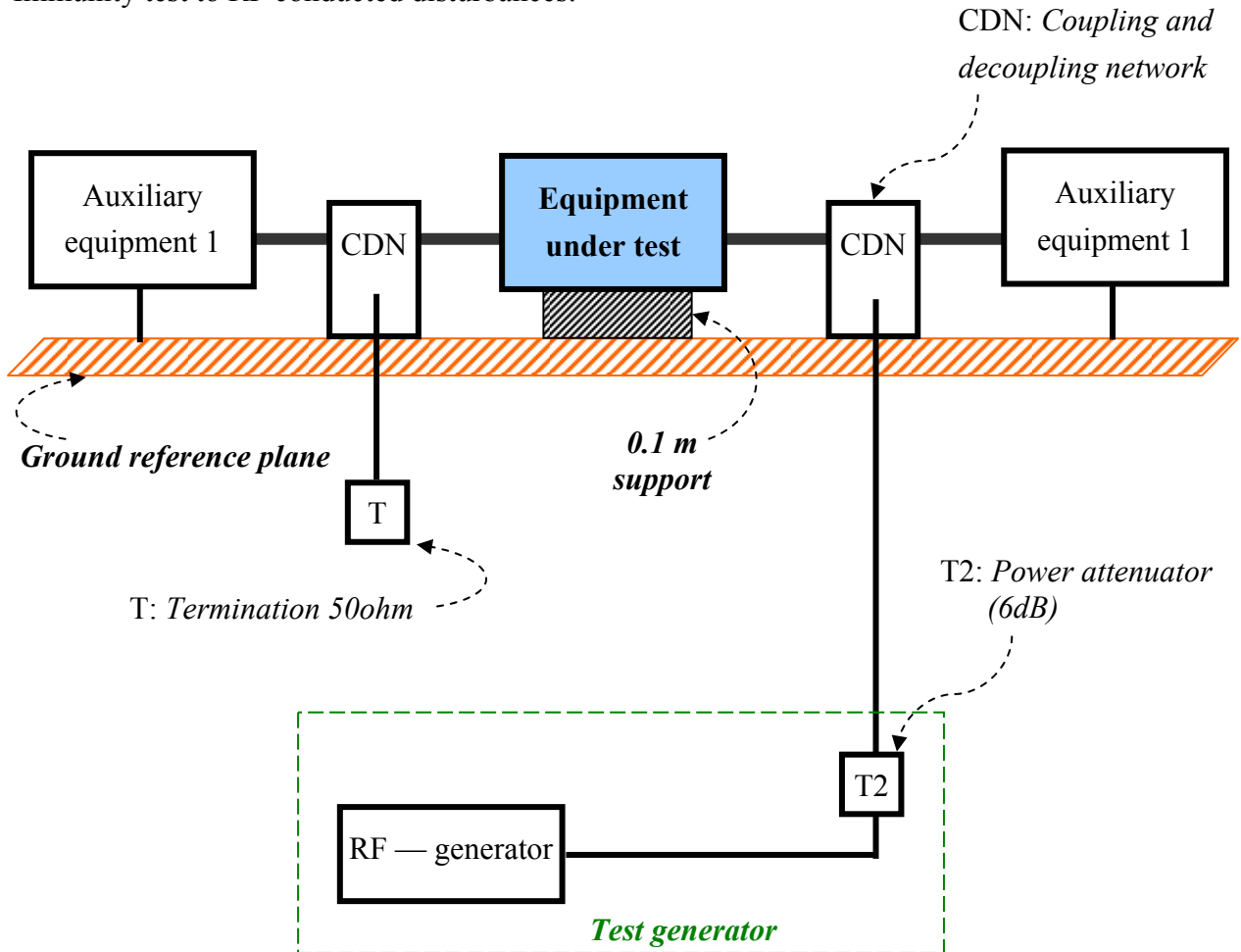

Test levels: (Apply Level 2)

Frequency range 150kHz to 80MHz		
Level	Voltage level (e.m.f.)	
	U_o [dB(μ v)]	U_o [V]
1	120	1
2	130	3
3	140	10
X	Special	

NOTE: the "X" is an open test level.

Test Frequency: 0.15 ~ 80MHz

Modulation: FM %
 80% AM Modulation with 1KHz

Step size: $\leq 1\%$ Step size

Signal Strength: 1Vrms
 3Vrms
 10Vrms

Test mode: Ref. Test method of Chapter 1

Test instruments:

Name	Model Number	Serial Number	Selected
FRANKONIA EMV-Mess-System	CIT-10	103A3113	X
FRANKONIA CDN	M2+M3	A3011015	X
FCC CDN	FCC-801-T2	04018	
FRANKONIA CDN	T4-801	A3015004	
FRANKONIA CDN	S1-801	A3005002	
SCHAFFNER FM-Koppelzange	KEMZ 801	17045	
SCHAFFNER RF-SYNTHE SIZERIAMP21FIER	NSG 2070-1	1020	
SCHAFFNER CDN	M325	13773	
SCHAFFNER CDN	M216	15604	
SCHAFFNER CDN	T004	15230	
SCHAFFNER CDN	S501	15167	
SCHAFFNER FM-Koppelzange	KEMZ 801	14301	
HP Transmission Test Set	4935A	3115A24046	
B & K Precision Sound Level Meter	Type 2232	1810564	

Comment:

Performance Criteria: (X) A () B () C

EN 61000-4-6 PHOTO OF TEST SET-UP



Chapter 9 Voltage DIP / Interruption Test

DIP Test information:

Test setup: According to EN 61000-4-11

Voltage dips: > 95% , 0.5 Period
 30% , 25 Period

Voltage interruptions: > 95% , 250 Periods

Test mode: Ref. Test method of Chapter 1

Test instruments:

Name	Model Number	Serial Number	Selected
Best Plus BURST ESD SURGE TRANSIENTS	Best Plus V6.2	199749-019SC	
BEST EMC Test Instrument	BEST EMC V2.3 (-8, -9)	199918-006SC	
Partner EMS Tester	Transienter-1000	PIO	X

Comment:

Performance Criteria:	Dips (1) >95%	<input type="checkbox"/> A	<input checked="" type="checkbox"/> B	<input type="checkbox"/> C
	Dips (2) 30%	<input type="checkbox"/> A	<input type="checkbox"/> B	<input checked="" type="checkbox"/> C
	Interruptions (1) >95%	<input type="checkbox"/> A	<input type="checkbox"/> B	<input checked="" type="checkbox"/> C

General performance criteria of EMS:

CRITERION A

The apparatus shall continue to operate as intended. No degradation of performance or loss of function is allowed below a performance level specified by the manufacturer, when the apparatus is used as intended.

CRITERION B

The apparatus shall continue to operate as intended after the test. No degradation of performance or loss of function is allowed below a performance level specified by the manufacturer, when the apparatus is used as intended.

CRITERION C

Temporary loss of function is allowed, provided the function is self-recoverable or can be restored by the operation of the controls.

EN 61000-4-11 PHOTO OF TEST SET-UP



Chapter 10 Harmonics Test

Test information:

Test setup: According to EN 61000-3-2

Test Item: Quasi – stationary & Fluctuating Current Harmonics Test.

Test mode: Ref. Test method of Chapter 1

Test instrument:

Name	Model Number	Serial Number
Universal Power Analyzer	PM6000	100006700226

Test Equipment Settings:	Quasi-stationary Current Harmonics Test	Fluctuating Current Harmonics Test
Line Voltage	230VAC	230VAC
Line Frequency	50Hz	50Hz
Device Class	A	A
Test Limit Overrides	None	None
Total Number of Failures	None	None
Total Number of Errors	None	None

Test Result: Pass

Chapter 11 Voltage Fluctuation and Flicker Test

Test information:

Test setup: According to EN 61000-3-3

Test mode: Ref. Test method of Chapter 1

Test instrument:

Name	Model Number	Serial Number
Harmonic/Flicker Test System	HP 6843A	3531A-00227

Test Equipment Settings	
Line Voltage	230VAC
Line Frequency	50Hz
Test Limit Overrides	None
Total Number of Failures	Pst: (0), Plt: (0) Dc: (0), Dmax (0), Dt (0)
Total Number of Errors	None

Test Result: Pass

Appendix A

Test Result of Conducted Emissions for Mains power

Testing room : Temperature : 16 ° C Humidity : 78 % RH

Line 1

Frequency (kHz)	READING AMPLITUDE			LIMIT		Margin (dB)
	Peak (dB μ V)	Quasi-Peak (dB μ V)	Average (dB μ V)	Quasi-Peak (dB μ V)	Average (dB μ V)	
180.000	51.91	---	---	65.15	55.15	-3.24
478.400	43.95	42.40	39.25	56.62	46.62	-7.55
536.200	45.01	44.46	41.44	56.00	46.00	-4.56
895.700	44.50	43.69	40.74	56.00	46.00	-5.26
1193.600	43.63	42.88	39.89	56.00	46.00	-6.11
1254.100	43.70	43.04	40.30	56.00	46.00	-5.70
1545.000	42.63	---	---	56.00	46.00	-3.37
3761.800	44.37	43.19	34.76	56.00	46.00	-11.24
4061.800	44.51	39.93	36.99	56.00	46.00	-9.01

Line 2

Frequency (kHz)	READING AMPLITUDE			LIMIT		Margin (dB)
	Peak (dB μ V)	Quasi-Peak (dB μ V)	Average (dB μ V)	Quasi-Peak (dB μ V)	Average (dB μ V)	
179.900	54.55	53.32	40.97	65.14	55.14	-11.83
479.100	44.96	43.77	40.58	63.46	53.46	-6.12
539.400	45.72	45.09	41.85	56.60	46.60	-4.15
898.100	44.28	43.90	40.87	56.00	46.00	-5.13
957.500	43.75	42.86	39.72	56.00	46.00	-6.28
1197.600	43.73	42.94	39.85	56.00	46.00	-6.15
1558.700	43.05	41.64	38.90	56.00	46.00	-7.10
1967.000	42.05	---	---	56.00	46.00	-3.95
3775.600	44.98	43.13	35.26	56.00	46.00	-10.74

Note:

1. The reading amplitudes are all under limit.
2. Testing result = Amplitude reading + Correction factor (Insertion loss of LISN, Cable loss, Attenuator, Amplifier and so on)

Appendix B

Test Conditions:

Testing room : Temperature : 15 ° C Humidity : 78 % RH
 Testing site : Temperature : 15 ° C Humidity : 78 % RH

Test Result of Radiated Emission (Horizontal)

Frequency	Reading Amplitude	Ant. Height	Table	Correction Factors	Corrected Amplitude	Class B Limit	Margin
MHz	dBμV	m	degree	dB/m	dBμV/m	dBμV/m	dB
40.0400	28.22	3.12	81	-5.05	23.17	30.00	-6.83
91.6638	33.26	2.14	85	-9.81	23.45	30.00	-6.55
97.6613	35.18	1.66	0	-9.18	26.00	30.00	-4.00
199.0875	32.39	1.32	40	-6.71	25.68	30.00	-4.32
206.4363	32.21	1.05	308	-6.76	25.45	30.00	-4.55
298.6175	32.18	1.00	305	-1.91	30.27	37.00	-6.73

Test Result of Radiated Emission (Vertical)

Frequency	Reading Amplitude	Ant. Height	Table	Correction Factors	Corrected Amplitude	Class B Limit	Margin
MHz	dBμV	m	degree	dB/m	dBμV/m	dBμV/m	dB
40.0400	31.98	3.76	219	-5.05	26.93	30.00	-3.07
67.9588	27.43	2.48	128	-5.86	21.57	30.00	-8.43
117.4875	30.62	1.64	298	-6.67	23.95	30.00	-6.05
133.6425	28.22	1.22	37	-5.19	23.03	30.00	-6.97
175.8375	27.66	1.17	305	-4.64	23.02	30.00	-6.98
305.4625	27.93	1.00	212	-1.75	26.18	37.00	-10.82

Note:

1. Margin = Amplitude – limit, if margin is minus means under limit.
2. Corrected Amplitude = Reading Amplitude + Correction Factors
3. Correction factor = Antenna factor + (Cable Loss – Amplitude gain) + Switching Box Loss
4. The highest frequency of internal sources of the EUT is less than 108 MHz, the measurement shell only be made up to 1 GHz.

Appendix C

Photographs of EUT







